

Service Manual

HP LaserJet 8000 (C4085A)

HP LaserJet 8000 N (C4086A)

HP LaserJet 8000 DN (C4087A)

HP LaserJet Mopier 240 (C4228A)

© Copyright
Hewlett-Packard Company 1998
All Rights Reserved.
Reproduction, adaptation, or
translation without prior written
permission is prohibited, except
as allowed under the copyright
laws.
Publication number
C4085-91017
First edition, May 1998

Warranty

The information contained in
this document is subject to
change without notice.

Hewlett-Packard makes no
warranty of any kind with regard
to this material, including, but
not limited to, the implied
warranties or merchantability
and fitness for a particular
purpose.

Hewlett-Packard shall not be
liable for errors contained herein
or for incidental or
consequential damages in
connection with the furnishing,
performance, or use of this
material.

WARNING

Electrical Shock Hazard

To avoid electrical shock, use
only supplied power cords and
connect only to properly
grounded (3-hole) wall outlets.

Adobe and PostScript are
trademarks of Adobe Systems
Incorporated which may be
registered in certain
jurisdictions.

CompuServe is a U.S.
trademark of CompuServe, Inc.

Windows is a U.S. registered
trademark of Microsoft
Corporation.

Conventions

This manual uses the following conventions:

The names of major printer parts and assemblies are Capitalized.

Color is used to emphasize items which are important to the material under discussion.

Bold is used for emphasis, particularly in situations where *italic* type would be confusing.

Italic type is used to indicate related documents or emphasis.

Note

Notes contain important information set off from the text.

CAUTION

Caution messages alert you to the possibility of damage to equipment or loss of data.

WARNING!

Warning messages alert you to the possibility of personal injury.

Chapter Descriptions

1 Product Information

Contains printer features and product overview, tray capacities and sizes, media specifications, service approach, how to get technical assistance, and required safety and compliance statements.

2 Site Requirements

Contains space and environmental requirements.

3 Operating Overview

Contains details about control panel menus, restoring factory defaults, and resetting and testing the printer.

4 Maintenance and Adjustments

Contains cleaning and preventive maintenance information, and adjustment procedures for paper trays.

5 Functional Overview

Contains block diagrams and basic theory of operation for the printer systems, paper paths, and paper handling accessories. Contains basic cabling information.

6 Removal and Replacement

Contains step-by-step procedures for replacing field replaceable units (FRUs) in the printer and paper-handling accessories.

7 Troubleshooting

Contains a preliminary troubleshooting table, a table with descriptions and recommended actions for all control panel messages, image defect samples, and troubleshooting checks and tools.

8 Parts and Diagrams

Contains exploded view drawings and part number listings for all replaceable parts in the printer and paper-handling accessories.

Contains two replaceable parts tables: one sorted alphabetically by part name, and one sorted numerically by part number. Both tables are cross referenced to the diagrams in the chapter.

Subject Index

Contains an alphabetical, cross referenced listing of information found in the main body of the manual.

Table of Contents

1 Product Information

Printer Features	2
Paper Capacities and Sizes	4
Identification	6
Model and Serial Numbers	6
Specifications	7
Media Selection Guidelines	11
Paper	11
Envelopes	11
Adhesive Labels	12
Transparencies	13
Storing Print Media	13
Shipping Print Media	13
Product Overview	14
External View of HP LaserJet 8000/N/DN Engine	14
External View of HP Mopier 240	16
Formatter Assemblies	18
Accessories and Options	19
Ordering Information	20
Hard Disk	26
Determining Memory Requirements	26
Service Approach	28
Ordering Parts	28
Exchange Program	29
Consumables	29
Toner Cartridge Life	29
Refilled Toner Cartridges & Non-HP Staple Cartridges	30
Recycling Toner Cartridges	30
Technical Assistance	31
HP FIRST (Fax Information Retrieval Support Technology)	31
HP CompuServe Forum	32
Internet	32
World Wide Web	32
HP Reseller Sales and Service Support Line	32
Other Areas	32
Warranty	33
Regulatory Information	35
FCC Regulations	35
Environmental Product Stewardship	36
Protecting the Environment	36

Material Safety Data Sheet38
Environmental Conformity39
Declaration of Conformity40
Safety Statements42
Laser Safety Statement42
Canadian DOC Regulations42
VCCI Statement (Japan)42
Korean EMI statement43
Laser Statement for Finland43

2 Site Requirements

Operating Environment46
Space Requirements47
Environmental Requirements49

3 Operating Overview

Using the Control Panel52
Control Panel Layout52
Indicator Lights53
Settings and Defaults54
Printer Driver Information54
Paper Source Default54
Resetting the Printer55
Setting the Display Language55
Control Panel Menus58
Information Menu59
Paper Handling Menu60
Print Quality Menu62
Printing Menu64
Configuration Menu67
I/O Menu70
EIO Menu72
Resets Menu74
Service Mode75
Setting Page Count, Maintenance Count, and Serial Number78
Setting the Cold Reset Default Paper Size79
Testing the Printer80
Paper Path Test80
Configuration Page80
Cold Reset85

4 Maintenance and Adjustments

Cleaning the Printer and Accessories	88
Cleaning Spilled Toner	90
Preventative Maintenance	91
Tray Adjustment Procedure	92
Tray 4 (2000-sheet Input Tray) Adjustment Procedure	94

5 Functional Overview

Printer Functional Block Diagram	98
Power Distribution System	99
AC Power Distribution	100
Overcurrent/Overvoltage Protection	100
High Voltage Power Distribution	101
Formatter System	102
DC Controller System	105
Laser and Scanner Drive	105
Paper Motion Monitoring and Control	105
Clutches	105
Engine Test Microswitch	106
Motors	106
Image Formation System	107
Toner Cartridge	108
Drum Cleaning	110
Drum Conditioning	111
Image Writing	112
Image Developing	113
Image Transferring and Media Separation	115
Image Fusing	116
Paper Paths and Components	117
Printer, Duplexer, and Envelope Feeder	117
2000-sheet Input Tray (Tray 4) Components	121
Multibin Mailbox Components	121
2 x 500-sheet Input Tray Components	122
7-bin Tabletop Mailbox Components	124
7-bin Tabletop Mailbox Operation	126
Operating Modes	126
Communication Link	128
Stapler Components	131
5-bin Mailbox with Stapler Operation	133
Main Functional Cycles of the Stapler	134

Printer Input Sources	136
Paper Size Switches	136
Printing from Trays 2 and 3	136
Printing from Tray 1	137
Printing from the Envelope Feeder	137
Printing from the 2000-sheet Input Tray (Tray 4) or 2 x 500-sheet Input Tray (Trays 4 and 5)	137
Two-Sided Printing	137
Paper Jam Detection	138
Printer Timing	138
IEEE 1284 Parallel Cable Information	142

6 Removal and Replacement

Removal and Replacement Strategy	145
Required Tools	146
User Installable Accessories	147
Disk Drive	148
Hardware Table	157
Control Panel	159
Covers	160
AC Access Cover	160
Back Cover	162
Front Cover	163
Left Lower Cover	165
Top Cover	166
Delivery Unit (for Standard Output Bin)	169
Diverter Assembly	172
Door Assembly, Diverter	173
Door Assembly, Right Lower	174
Fan 1, Exhaust (Laser/Scanner) and Housing	177
Fan Housing	177
Fan Motor	178
Fan 2, Exhaust (LVPS)	179
Fan 3, Intake (Formatter) and Housing	180
Fan Motor	180
Fan Housing (See Fan 2)	181
Fan 4, Exhaust (Delivery Unit)	182
Feeder Assembly	183
Formatter Assembly	185
Fusing Assembly	187
Laser/Scanner Assembly	189
Main Gear Assembly	191
Main Motor Assembly	194
Paper Input Unit (PIU)	195
PCA, DC Controller	197

PCA, Output Paper Sensor	198
PCA, Paper Size	202
Power Supply, High Voltage (HVPS)	205
Power Supply, Low Voltage (LVPS)	206
Registration Assembly	207
Roller and Separation Pad, Tray 1	210
Feed Roller	210
Separation Pad	211
Rollers: Tray Pickup, Feed, and Separation	212
Sensor, Paper Input Unit (PS2)	214
Sensor, Registration (PS1)	216
Solenoid Assembly, SL3 (Face-Up)	218
Transfer Roller Assembly	219
Tray 1 Assembly	221
Tray 2 and 3 Assemblies	222
Mailbox With Stapler	223
Covers	223
Delivery Head Assembly	224
Flipper Assembly	227
Input Paper Guide	230
Interlock Switch	231
Jam Access Door Assembly	232
Lower Elevator Pulley Assemblies	235
Metallic Tape and Housing Assembly	237
Motor, Delivery Head Position	240
Motor, Transport Belt and Encoder Assembly	241
Paper Bins and Blind Cover	244
PCA, Controller	245
Strings, Anti-Curl	246
Stapler Assembly	249
Back Plate	250
Stapler Controller PCA	252
Top Cover Assembly	255
Stapler Bed Assembly	256
Hinges	258
7-bin Tabletop Mailbox	259
7-bin Tabletop Mailbox Front Cover	260
7-bin Tabletop Mailbox Back Cover	263
7-bin Tabletop Mailbox Top Cover	265
7-bin Tabletop Mailbox Controller PCA	269
7-bin Tabletop Mailbox Power Supply	270
7-bin Tabletop Mailbox Right Door Assembly (Paper Path Cover)	271
7-bin Tabletop Mailbox Face Down Bins	275
7-bin Tabletop Mailbox Empty Bin Sensor PCA	278
7-bin Tabletop Mailbox Full Bin and Interlock Sensor PCA	280

7-bin Tabletop Mailbox LED PCA282
7-bin Tabletop Mailbox Face Up Sensors PCA283
7-bin Tabletop Mailbox Reversing Mechanism Motor284
7-bin Tabletop Mailbox Face Up/Diverter Assembly (Flipper)286
7-bin Tabletop Mailbox Short Tray 7289
7-bin Tabletop Mailbox Solenoid Reversing Mechanism290
7-bin Tabletop Mailbox Solenoid Flipper291
7-bin Tabletop Mailbox Handle292
7-bin Tabletop Mailbox Latching Mechanism293
7-bin Tabletop Mailbox Cover Latch294
2 x 500-sheet Input Tray295
2 x 500-sheet Input Tray Back Cover296
2 x 500-sheet Input Tray Left Cover297
2 x 500-sheet Input Tray Vertical Transfer Unit (VTU)298
2 x 500-sheet Input Tray Right Cover301
2 x 500-sheet Input Tray Front Top Cover304
2 x 500-sheet Input Tray (Trays 4 and 5)307
2 x 500-sheet Input Tray Pickup Assembly309
2 x 500-sheet Input Tray Paper Deck Drive Assembly311
2 x 500-sheet Input Tray Pickup, Feed, and Separation Rollers313
2 x 500-sheet Input Tray Controller PCA314
2 x 500-sheet Input Tray Cassette-Size Sensing PCA315
2 x 500-sheet Input Tray Power Supply317
2 x 500-sheet Input Tray Main Cable318
2 x 500-sheet Input Tray Storage Paper Tray320
2 x 500-sheet Input Tray Front Door (Storage Area)321
2 x 500-sheet Input Tray Outriggers (Leveling Feet)322
2 x 500-sheet Input Tray Casters323
2 x 500-sheet Input Tray Foot Tip and Adjustable Foot Tip324
2 x 500-sheet Input Tray Locating Pins325
2 x 500-sheet Input Tray Front LED PCA326

7 Troubleshooting

Troubleshooting Process328
Power On332
Overview332
Engine Test335
Display336
Event Log336
Information Pages340
Menu Map340
Configuration Page342

Communication	346
Interface Troubleshooting	346
Verify Host System Operation	350
Verify Network and Server Operation	350
Printer Messages	351
Control Panel Messages and Errors	351
Event Log Table	352
Image Quality	394
Check the Toner Cartridge	395
Image Quality Tables	396
Repetitive Defect Ruler	408
Image System Troubleshooting	409
High-Voltage Power Supply Check	410
Troubleshooting Checks	412
Paper Jams	412
General Paper Path Troubleshooting	414
Paper Path Test	415
Diagnostics on Accessories	418
2 x 500-sheet Input Tray Standalone Diagnostics	418
7-Bin Tabletop Mailbox Standalone Diagnostics	422
General Troubleshooting Information	426
Miscellaneous Problems and Solutions	426
Paper Curl	431
Diagrams	432

8 Parts and Diagrams

How to Use the Part Lists and Diagrams	442
Ordering Parts	442
Accessories and Supplies	443
Common Hardware	443
Illustrations and Parts Lists	444
Alphabetical Parts List	467
Numerical Parts List	475

List of Figures

Figure 1-1.	Sample Model and Serial Number Label for the Printer	6
Figure 1-2.	HP LaserJet 8000/N/DN Engine - Front and Right Side View with Tray 1 Open	14
Figure 1-3.	HP Mopier 240 - Front and Right Side View with Tray 1 Open	16
Figure 1-4.	Rear and Left Side View	18
Figure 1-5.	HP LaserJet 8000/N/DN Optional Paper Handling Accessories-	19
Figure 1-6.	Sample 5% Page Coverage-	29
Figure 2-1.	Printer Space Requirements (Top view)	47
Figure 2-2.	Printer Space Requirements (Side view)-	47
Figure 2-3.	Printer Space Requirements (with Multibin Mailbox and Input Device)	48
Figure 3-1.	Control Panel Layout	52
Figure 3-2.	Configuration Page	81
Figure 3-3.	Menu Map Page	83
Figure 4-1.	Image Area Margins	92
Figure 4-2.	Tray Position Adjustment	93
Figure 4-3.	Tray 4 Position Adjustment	94
Figure 5-1.	Printer Functional Block Diagram	98
Figure 5-2.	Low Voltage Power Distribution System	99
Figure 5-3.	Low Voltage Power Supply	100
Figure 5-4.	High Voltage Power Supply Contacts	101
Figure 5-5.	Normal Mode vs EconoMode	104
Figure 5-6.	Image Formation Block Diagram	107
Figure 5-7.	Photosensitive Drum	109
Figure 5-8.	Drum Cleaning	110
Figure 5-9.	Primary Charging Roller-	111
Figure 5-10.	Image Writing-	112
Figure 5-11.	Image Development	114
Figure 5-12.	Image Transferring and Media Separation-	115
Figure 5-13.	Image Fusing-	116
Figure 5-14.	Printer Paper Paths	117
Figure 5-15.	Printer Sensors, Solenoids, Clutches, Motors, and Fans	118
Figure 5-16.	2 x 500-sheet Input Tray Paper Path	122
Figure 5-17.	7-bin Tabletop Mailbox Components (1 of 2)-	124
Figure 5-18.	7-bin Tabletop Mailbox Components (2 of 2)-	125
Figure 5-19.	C-link Connection-	129
Figure 5-20.	C-Link Configuration (Recommended)-	130
Figure 5-21.	Stapler Motors, Sensors, and Switches	132
Figure 5-22.	Stapler Cycles	135
Figure 5-23.	General Timing Diagram (1 of 2)	140
Figure 5-24.	General Timing Diagram (2 of 2)	141

Figure 5-25.	Parallel Cable Pin Assignments (C2946A) - - - - -	142
Figure 6-1.	Phillips vs. Posidriv Screwdrivers - - - - -	146
Figure 6-2.	Disk Drive - - - - -	148
Figure 6-3.	Control Panel - - - - -	159
Figure 6-4.	AC Access Cover - - - - -	160
Figure 6-5.	Back Cover - - - - -	162
Figure 6-6.	Front Cover (1 of 2) - - - - -	163
Figure 6-7.	Front Cover (2 of 2) - - - - -	164
Figure 6-8.	Left Lower Cover - - - - -	165
Figure 6-9.	Top Cover (1 of 2) - - - - -	166
Figure 6-10.	Top Cover (2 of 2) - - - - -	167
Figure 6-11.	Delivery Unit (1 of 2) - - - - -	169
Figure 6-12.	Delivery Unit (2 of 2) - - - - -	170
Figure 6-13.	Diverter Assembly - - - - -	172
Figure 6-14.	Diverter Door Assembly - - - - -	173
Figure 6-15.	Right Lower Door Assembly (1 of 3) - - - - -	174
Figure 6-16.	Right Lower Door Assembly (2 of 3) - - - - -	175
Figure 6-17.	Right Lower Door Assembly (3 of 3) - - - - -	176
Figure 6-18.	Fan 1, Laser/Scanner (1 of 2) - - - - -	177
Figure 6-19.	Fan 1, Laser/Scanner (2 of 2) - - - - -	178
Figure 6-20.	Fan 2, LVPS - - - - -	179
Figure 6-21.	Fan 3, Formatter - - - - -	180
Figure 6-22.	Fan 4, Delivery Unit - - - - -	182
Figure 6-23.	Feeder Assembly (1 of 2) - - - - -	183
Figure 6-24.	Feeder Assembly (2 of 2) - - - - -	184
Figure 6-25.	Formatter Assembly - - - - -	186
Figure 6-26.	Fusing Assembly - - - - -	187
Figure 6-27.	Laser/Scanner Assembly - - - - -	189
Figure 6-28.	Main Gear Assembly (1 of 3) - - - - -	191
Figure 6-29.	Main Gear Assembly (2 of 3) - - - - -	192
Figure 6-30.	Main Gear Assembly (3 of 3) - - - - -	193
Figure 6-31.	Main Motor - - - - -	194
Figure 6-32.	Paper Input Unit - - - - -	195
Figure 6-33.	DC Controller PCA - - - - -	197
Figure 6-34.	Output Paper Sensor PCA (1 of 4) - - - - -	198
Figure 6-35.	Output Paper Sensor PCA (2 of 4) - - - - -	199
Figure 6-36.	Output Paper Sensor PCA (3 of 4) - - - - -	200
Figure 6-37.	Output Paper Sensor PCA (4 of 4) - - - - -	201
Figure 6-38.	Paper Size PCA (1 of 3) - - - - -	202
Figure 6-39.	Paper Size PCA (2 of 3) - - - - -	203
Figure 6-40.	Paper Size PCA (3 of 3) - - - - -	204
Figure 6-41.	High Voltage Power Supply - - - - -	205
Figure 6-42.	Low Voltage Power Supply - - - - -	206
Figure 6-43.	Registration Assembly (1 of 3) - - - - -	207
Figure 6-44.	Registration Assembly (2 of 3) - - - - -	208
Figure 6-45.	Registration Assembly (3 of 3) - - - - -	209
Figure 6-46.	Tray 1 Feed Roller - - - - -	210

Figure 6-47.	Tray 1 Separation Pad	- - - - -	211
Figure 6-48.	Tray 2 and 3, Pickup, Feed, and Separation Rollers	- - - - -	212
Figure 6-49.	Paper Input Unit Sensor (PS2)	- - - - -	214
Figure 6-50.	Registration Sensor (PS1)	- - - - -	216
Figure 6-51.	Face-Up Solenoid Assembly, SL3	- - - - -	218
Figure 6-52.	Transfer Roller Assembly	- - - - -	219
Figure 6-53.	Tray 1 Assembly	- - - - -	221
Figure 6-54.	Mailbox with Stapler Covers	- - - - -	223
Figure 6-55.	Mailbox with Stapler, Delivery Head Ribbon Cable	- - - - -	224
Figure 6-56.	Mailbox with Stapler, Delivery Head Mounting Screws	- - - - -	225
Figure 6-57.	Mailbox with Stapler, Delivery Head Pulley Detail	- - - - -	226
Figure 6-58.	Mailbox with Stapler, Flipper Assembly Connector	- - - - -	227
Figure 6-59.	Mailbox with Stapler, Flipper Assembly Mounting Screws	- - - - -	228
Figure 6-60.	Mailbox with Stapler, Flipper Assembly Ground Wire	- - - - -	229
Figure 6-61.	Mailbox with Stapler, Input Paper Guide	- - - - -	230
Figure 6-62.	Mailbox with Stapler, Interlock Switch	- - - - -	231
Figure 6-63.	Mailbox with Stapler, Jam Access Door Springs	- - - - -	232
Figure 6-64.	Mailbox with Stapler, Jam Access Door E-Clip	- - - - -	233
Figure 6-65.	Mailbox with Stapler, Jam Access Door String Connection	- - - - -	234
Figure 6-66.	Mailbox with Stapler, Elevator Pulley Tension Spring	- - - - -	235
Figure 6-67.	Mailbox with Stapler, Pulley Housing Release	- - - - -	236
Figure 6-68.	Mailbox with Stapler, Metallic Tape Retaining Pin	- - - - -	237
Figure 6-69.	Mailbox with Stapler, Metallic Tape Release	- - - - -	238
Figure 6-70.	Mailbox with Stapler, Metallic Tape Housing	- - - - -	239
Figure 6-71.	Mailbox with Stapler, Delivery Head Motor	- - - - -	240
Figure 6-72.	Mailbox with Stapler, Transport Belt Motor Screws	- - - - -	241
Figure 6-73.	Mailbox with Stapler, Transport Belt Drive Gear	- - - - -	242
Figure 6-74.	Mailbox with Stapler, Transport Belt Encoder	- - - - -	243
Figure 6-75.	Mailbox with Stapler, Bin Removal	- - - - -	244
Figure 6-76.	Mailbox with Stapler, PCA Removal	- - - - -	245
Figure 6-77.	Mailbox with Stapler, Anti-Curl String Lower Connection	- - - - -	246
Figure 6-78.	Mailbox with Stapler, Anti-Curl String Upper Connection	- - - - -	247
Figure 6-79.	Mailbox with Stapler, Anti-Curl String Middle Connection	- - - - -	248
Figure 6-80.	Mailbox with Stapler, Stapler Removal	- - - - -	249
Figure 6-81.	Back Plate (1 of 2)	- - - - -	250
Figure 6-82.	Back Plate (2 of 2)	- - - - -	251
Figure 6-83.	Stapler Controller PCA (1 of 3)	- - - - -	252
Figure 6-84.	Stapler Controller PCA (2 of 3)	- - - - -	253
Figure 6-85.	Stapler Controller PCA (3 of 3)	- - - - -	254
Figure 6-86.	Top Cover Assembly	- - - - -	255
Figure 6-87.	Stapler Bed Assembly	- - - - -	256
Figure 6-88.	Hinges	- - - - -	258
Figure 6-89.	Orientation of the 7-bin Tabletop Mailbox	- - - - -	259
Figure 6-90.	Front cover (1 of 3)	- - - - -	260
Figure 6-91.	Front cover (2 of 3)	- - - - -	261
Figure 6-92.	Front cover (3 of 3)	- - - - -	262
Figure 6-93.	Back cover (1 of 2)	- - - - -	263

Figure 6-94. Back cover (2 of 2) - - - - -	264
Figure 6-95. Top cover (1 of 4)- - - - -	265
Figure 6-96. Top cover (2 of 4)- - - - -	266
Figure 6-97. Top cover (3 of 4)- - - - -	267
Figure 6-98. Top cover (4 of 4)- - - - -	268
Figure 6-99. Mailbox Controller PCA - - - - -	269
Figure 6-100. Mailbox Power Supply - - - - -	270
Figure 6-101. Right Door Assembly (Paper Path Cover) (1 of 4) - - - - -	271
Figure 6-102. Right Door Assembly (Paper Path Cover) (2 of 4) - - - - -	272
Figure 6-103. Right Door Assembly (Paper Path Cover) (3 of 4) - - - - -	273
Figure 6-104. Right Door Assembly (Paper Path Cover) (4 of 4) - - - - -	274
Figure 6-105. Face Down Bins (1 of 3) - - - - -	275
Figure 6-106. Face Down Bins (2 of 3) - - - - -	276
Figure 6-107. Face Down Bins (3 of 3) - - - - -	277
Figure 6-108. Empty Bin Sensor PCA (1 of 2) - - - - -	278
Figure 6-109. Empty Bin Sensor PCA (2 of 2) - - - - -	279
Figure 6-110. Full Bin and Interlock Sensor PCA (1 of 2)- - - - -	280
Figure 6-111. Full Bin and Interlock Sensor PCA (2 of 2)- - - - -	281
Figure 6-112. LED PCA - - - - -	282
Figure 6-113. Face Up Sensors PCA - - - - -	283
Figure 6-114. Reversing Mechanism Motor (1 of 2) - - - - -	284
Figure 6-115. Reversing Mechanism Motor (2 of 2) - - - - -	285
Figure 6-116. Face Up/Diverter Assembly (Flipper) (1 of 3) - - - - -	286
Figure 6-117. Face Up/Diverter Assembly (Flipper) (2 of 3) - - - - -	287
Figure 6-118. Face Up/Diverter Assembly (Flipper) (3 of 3) - - - - -	288
Figure 6-119. Short Tray 7 - - - - -	289
Figure 6-120. Solenoid Reversing Mechanism - - - - -	290
Figure 6-121. Solenoid Flipper - - - - -	291
Figure 6-122. Handle - - - - -	292
Figure 6-123. Latching Mechanism - - - - -	293
Figure 6-124. Cover Latch - - - - -	294
Figure 6-125. Orientation of the 2 x 500-sheet Input Tray - - - - -	295
Figure 6-126. Back Cover - - - - -	296
Figure 6-127. Left Cover - - - - -	297
Figure 6-128. Vertical Transfer Unit (VTU) (1 of 3) - - - - -	298
Figure 6-129. Vertical Transfer Unit (VTU) (2 of 3) - - - - -	299
Figure 6-130. Vertical Transfer Unit (VTU) (3 of 3) - - - - -	300
Figure 6-131. Right Cover (1 of 3) - - - - -	301
Figure 6-132. Right Cover (2 of 3) - - - - -	302
Figure 6-133. Right Cover (3 of 3) - - - - -	303
Figure 6-134. Front Top Cover (1 of 3) - - - - -	304
Figure 6-135. Front Top Cover (2 of 3) - - - - -	305
Figure 6-136. Front Top Cover (3 of 3) - - - - -	306
Figure 6-137. Trays 4 & 5 (1 of 2) - - - - -	307
Figure 6-138. Trays 4 & 5 (2 of 2) - - - - -	308
Figure 6-139. Pickup Assembly (1 of 2) - - - - -	309
Figure 6-140. Pickup Assembly (2 of 2) - - - - -	310

Figure 6-141. Paper Deck Drive Assembly (1 of 2) - - - - -	311
Figure 6-142. Paper Deck Drive Assembly (2 of 2) - - - - -	312
Figure 6-143. Pickup, Feed, and Separation Rollers - - - - -	313
Figure 6-144. 2 x 500-sheet Input Tray Controller PCA- - - - -	314
Figure 6-145. Cassette-Size Sensing PCA (1 of 2)- - - - -	315
Figure 6-146. Cassette-Size Sensing PCA (2 of 2)- - - - -	316
Figure 6-147. Power Supply- - - - -	317
Figure 6-148. Main Cable (1 of 2) - - - - -	318
Figure 6-149. Main Cable (2 of 2) - - - - -	319
Figure 6-150. Storage Paper Tray - - - - -	320
Figure 6-151. Front Door (Storage Area) - - - - -	321
Figure 6-152. Outriggers (Leveling Feet) - - - - -	322
Figure 6-153. Casters - - - - -	323
Figure 6-154. Foot Tip and Adjustable Foot Tip - - - - -	324
Figure 6-155. Locating Pins - - - - -	325
Figure 6-156. Front LED PCA - - - - -	326
Figure 7-1. HP LaserJet Troubleshooting Process (1 of 2) - - - - -	330
Figure 7-2. HP LaserJet Troubleshooting Process (2 of 2) - - - - -	331
Figure 7-3. Fan Location and Airflow - - - - -	334
Figure 7-4. Engine Test Button - - - - -	335
Figure 7-5. Sample Event Log - - - - -	337
Figure 7-6. Sample Menu Map - - - - -	341
Figure 7-7. Sample Configuration Page - - - - -	343
Figure 7-8. Communications Link (C-link) Cables, Supported Daisy Chain Connections - - - - -	346
Figure 7-9. Sample JetDirect Configuration Page - - - - -	349
Figure 7-10. Repetitive Defect Ruler - - - - -	408
Figure 7-11. High Voltage Power Supply Contacts - - - - -	411
Figure 7-12. Paper Path Jam Locations - - - - -	413
Figure 7-13. Paper Path Test Source and Output Selection - - - - -	416
Figure 7-14. Printer Sensors and Switches - - - - -	433
Figure 7-15. Printer Motor, Clutches, and Solenoids - - - - -	434
Figure 7-16. DC Controller Inputs and Outputs (1 of 5) - - - - -	435
Figure 7-17. DC Controller Inputs and Outputs (2 of 5) - - - - -	436
Figure 7-18. DC Controller Inputs and Outputs (3 of 5) - - - - -	437
Figure 7-19. DC Controller Inputs and Outputs (4 of 5) - - - - -	438
Figure 7-20. DC Controller Inputs and Outputs (5 of 5) - - - - -	439
Figure 7-21. Mailbox with Stapler Wiring Diagram - - - - -	440
Figure 8-1. HP LaserJet 8000/N/DN or HP Mopier 240 Printer and Paper-Handling Components - - - - -	445
Figure 8-2. Printer Covers and Doors - - - - -	448
Figure 8-3. Printer Internal Components (1 of 4)- - - - -	450
Figure 8-4. Printer Internal Components (2 of 4)- - - - -	452
Figure 8-5. Printer Internal Components (3 of 4)- - - - -	455
Figure 8-6. Printer Internal Components (4 of 4)- - - - -	457

Figure 8-7. Stapler Internal Components - - - - - 459
Figure 8-8. 2 x 500-sheet Input Tray Internal Components- - - - - 461
Figure 8-9. 7-bin Tabletop Mailbox Internal Components - - - - - 464

List of Tables

Table 1-1.	Common features between the HP LaserJet 8000, HP LaserJet 8000 N, HP LaserJet 8000 DN, and HP Mopier 240	2
Table 1-2.	Comparison of Printer Features	3
Table 1-3.	Paper Capacities and Sizes	4
Table 1-4.	Printer and Accessory Dimensions	7
Table 1-5.	Electrical Specifications	9
Table 1-6.	Acoustic Emissions	10
Table 1-7.	Accessories and Options	20
Table 1-8.	Minimum Memory Requirements	27
Table 2-1.	Printer and Toner Cartridge Environmental Conditions	49
Table 3-1.	Control Panel Keys	52
Table 3-2.	Indicator Lights	53
Table 3-3.	Factory Default Settings	56
Table 3-4.	Information Menu	59
Table 3-5.	Paper Handling Menu	60
Table 3-6.	Print Quality Menu	62
Table 3-7.	Printing Menu	64
Table 3-8.	Configuration Menu	67
Table 3-9.	I/O Menu	70
Table 3-10.	EIO Menu	72
Table 3-11.	Resets Menu	74
Table 3-12.	Service Mode Menu Items	76
Table 3-13.	Key to Figure 3-2	82
Table 3-14.	Key to Figure 3-3	84
Table 4-1.	Cleaning the Printer	90
Table 5-1.	Printer Sensors, Solenoids, Clutches, Motors, and Fans	119
Table 5-2.	2 x 500-sheet Input Tray Switches	122
Table 5-3.	7-bin Tabletop Mailbox Sensors, Switches, and Motors	125
Table 5-4.	Stapler Major Assemblies and Subassemblies	131
Table 5-5.	Stapler Motors, Sensors, and Switches	132
Table 5-6.	Paper Size Switches	136
Table 5-7.	Printer Timing	138
Table 6-1.	Hardware Table	157
Table 7-1.	Major Steps for Troubleshooting	328
Table 7-2.	Power On	332
Table 7-3.	Fans	334
Table 7-4.	Printer Devices Troubleshooting	345
Table 7-5.	Alphabetical Printer Messages	352
Table 7-6.	Numerical Printer Messages	373
Table 7-7.	Image Quality	394

Table 7-8.	Blank (White) Page - - - - -	396
Table 7-9.	Black Pages - - - - -	396
Table 7-10.	Fading Print - - - - -	397
Table 7-11.	Dropout- - - - -	398
Table 7-12.	Black Lines (parallel or perpendicular to path) - - - - -	399
Table 7-13.	Toner Smear - - - - -	400
Table 7-14.	Background Scatter- - - - -	400
Table 7-15.	Repetitive Defects - - - - -	401
Table 7-16.	Line at Edge of Paper- - - - -	402
Table 7-17.	Misshapen Characters, Voids - - - - -	402
Table 7-18.	Faulty Registration - - - - -	403
Table 7-19.	Image Skew - - - - -	404
Table 7-20.	Bubble Print - - - - -	405
Table 7-21.	White Stripes Parallel to Path - - - - -	405
Table 7-22.	Partial Blank Page - - - - -	406
Table 7-23.	Compressed Print- - - - -	406
Table 7-24.	Blank Portion in the Middle of the Page (Tray 4 Input only)- - - -	407
Table 7-25.	General Paper Path Troubleshooting Questions - - - - -	414
Table 7-26.	DIP switch settings for troubleshooting test procedures - - - - -	418
Table 7-27.	Patterns of LED flashing (2-second pause between each pattern)- - - - -	421
Table 7-28.	DIP switch settings for troubleshooting test - - - - -	422
Table 7-29.	Patterns of Flashing LEDs - - - - -	424
Table 7-30.	Paper Curl - - - - -	431
Table 8-1.	Printer and Paper-Handling Components - - - - -	446
Table 8-2.	Printer Covers and Doors - - - - -	449
Table 8-3.	Printer Internal Components (1 of 4)- - - - -	451
Table 8-4.	Printer Internal Components (2 of 4)- - - - -	453
Table 8-5.	Printer Internal Components (3 of 4)- - - - -	456
Table 8-6.	Printer Internal Components (4 of 4)- - - - -	458
Table 8-7.	Stapler Internal Components - - - - -	460
Table 8-8.	2 x 500-sheet Input Tray Internal Components- - - - -	462
Table 8-9.	7-bin Tabletop Mailbox Internal Components - - - - -	465
Table 8-10.	Alphabetical Parts List - - - - -	467
Table 8-11.	Numerical Parts List - - - - -	475

1

Product Information

Chapter Contents

Printer Features - - - - -	2
Paper Capacities and Sizes - - - - -	4
Identification - - - - -	6
Specifications - - - - -	7
Media Selection Guidelines - - - - -	11
Product Overview - - - - -	14
Service Approach - - - - -	28
Technical Assistance - - - - -	31
Warranty - - - - -	33
Regulatory Information - - - - -	35
Declaration of Conformity - - - - -	40

Printer Features

Table 1-1. Common features between the HP LaserJet 8000, HP LaserJet 8000 N, HP LaserJet 8000 DN, and HP Mopier 240

Feature	Description
Print Speed	24 ppm letter or A4 13 ppm ledger (11 x 17) or A3 15 ppm legal or B4
Duplex Speed	9.5 ppm letter or A4 6.5 ppm ledger or A3 7.5 ppm legal or B4
Text & Graphics Resolution	FastRes 1200 provides 1200 dpi quality at full speed plus Resolution Enhancement technology (REt)
Standard Printer Languages:	Enhanced PCL 6 PCL 5e for compatibility Postscript™ Level 2 emulation
Duty Cycle (Monthly Usage)	Up to 130,000 images
Internal Typefaces	45 PCL, 35 PostScript
Cartridge Slots	None
Power Control	PowerSave Mode
Control Panel	6 Keys, LCD Display (2-line, 16 characters per line)
EconoMode (toner saving)	Yes

Table 1-2. Comparison of Printer Features

Features	HP LaserJet 8000 (C4085A)	HP LaserJet 8000 N (C4086A)	HP LaserJet 8000 DN (C4087A)	HP Mopier 240 (C4228A)
Memory: ¹	16 MB ²	16 MB ²	24 MB ³	24 MB ³
Standard Interfaces	IEEE 1284 ECP Parallel A to C connector	IEEE 1284 ECP Parallel A to C connector JetDirect EIO	IEEE 1284 ECP Parallel A to C connector JetDirect EIO	IEEE 1284 ECP Parallel A to C connector JetDirect EIO
Duplexer	Optional	Optional	Standard	Standard
Hard Disk	Optional	Optional	Optional	Standard

-
1. Printer memory is optimized with Memory Enhancement technology (MEt). DIMMs available for use include 4, 8, 16, and 64 MB modules. See “Accessories and Supplies” in Chapter 8 for option product numbers. (32 MB modules are compatible, but not available from HP.) SDRAM available includes 4, 8, 16, 32, and 64 MB modules. EDO RAM available includes 4, 8, and 16 MB modules. A maximum of 192 MB RAM can be configured.
 2. Eight MB on-board RAM, one 8 MB DIMM.
 3. Eight MB on-board RAM, one 16 MB DIMM.

Paper Capacities and Sizes

Table 1-3. Paper Capacities and Sizes

Tray or Bin	Capacity	Paper	Weight
Tray 1 (multipurpose)	up to 100 sheets	<ul style="list-style-type: none"> Paper sizes: Letter, ISO A4, Executive, A5, Legal, 11 x 17, ISO A3, JIS B5, JIS B4, JPostD Custom sizes: Minimum: 3.67 x 7.5 in. (93 x 191 mm) Maximum: 11.7 x 17.7 in. (297 x 450 mm) <p>Note: You may print on both sides of paper that is equal to or larger than 5 by 7.5 in. (127 by 191 mm).</p> <ul style="list-style-type: none"> Other media types: transparencies, envelopes, and labels <p>Note: It is best to use Tray 1 when printing envelopes, transparencies, and labels.</p>	16 to 53 lb Bond (60 to 199 g/m ²) Two-sided: 16 to 20 lb Bond (60 to 75 g/m ²)
Tray 2 and Optional 2 x 500-sheet Input Tray (Tray 4)	up to 500 sheets	Paper sizes: Letter, ISO A4, Legal, JIS B4	16 to 28 lb (60 to 105 g/m ²)
Tray 3 and Optional 2 x 500-sheet Input Tray (Tray 5)	up to 500 sheets	Paper sizes: Letter, ISO A4, Legal, JIS B4, ISO A3, 11 x 17	16 to 28 lb (60 to 105 g/m ²)
2 x 500-sheet Input Tray	up to 1,000 sheets	Paper sizes: Letter, ISO A4, Legal, JIS B4, ISO A3, 11 x 17	16 to 28 lb (60 to 105 g/m ²)

Table 1-3. Paper Capacities and Sizes (continued)

Tray or Bin	Capacity	Paper	Weight
Optional 2000-sheet Input Tray (Tray 4)	up to 2,000 sheets	Paper sizes: Letter, ISO A4, Legal, JIS B4, ISO A3, 11 x 17	16 to 28 lb (60 to 105 g/m ²)
Standard Output Bin (face-down)	up to 500 sheets	Paper sizes: Letter, ISO A4, A5, Executive, Legal, 11 x 17, ISO A3, JIS B5, JIS B4	
Left Output Bin (face-up)	up to 100 sheets	Paper sizes: Letter, ISO A4, A5, Executive, Legal, 11 x 17, ISO A3, JIS B5, JIS B4	
5-bin Mailbox with Stapler and Multibin Mailbox (8 bins)	up to 250 sheets per bin	Paper sizes: Letter, ISO A4, Legal, JIS B4, ISO A3, 11 x 17, envelopes, transparencies, and labels Note: Envelopes, transparencies, and labels are only supported in the left output bin. The staple bin only supports A4 and Letter paper sizes.	16 to 28 lb (60 to 105 g/m ²)
7-bin Tabletop Mailbox	up to 120 sheets per bin	Paper sizes: Letter, ISO A4, Legal, B5, JIS B4, 11 x 17, ISO A3, envelopes, transparencies, labels Note: B5, JIS B4, 11 x 17, ISO A3, envelopes, transparencies, and labels are only supported in the left output bin.	16 to 28 lb (60 to 105 g/m ²)
Envelope Feeder	up to 100 envelopes	Envelope sizes: Commercial #10, C5, DL, Monarch, ISO B5, JPostD	16 to 24 lb (60 to 90 g/m ²)
Duplexer		Paper sizes: Letter, Legal, 11 x 17, A3, A4, B4	16 to 28 lb (60 to 105 g/m ²)

Identification

Model and Serial Numbers

The model and serial numbers are listed on identification labels located on the rear of the printer. The model number is alphanumeric, such as C4085A for the HP LaserJet 8000 printer and C4228A for the HP Mopier 240.

The serial number contains information about the Country of Origin, the Revision Level, the Production Code, and production number of the printer.

The rear labels also contain power rating and regulatory information as shown in figure 1-1.

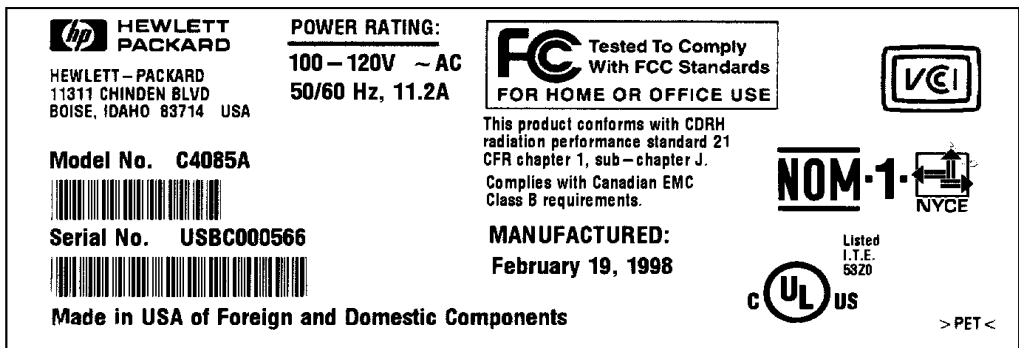

Figure 1-1 Sample Model and Serial Number Label for the Printer

The identification labels for the 2000-sheet Input Tray and 2 x 500-sheet Input Tray are located on the back panel, directly below the identification labels on the printer.

To locate the identification labels for the 8-bin Multibin Mailbox and 5-bin Multibin Mailbox with Stapler, detach the accessory from the printer. The identification labels are located on the bottom right of the front side (side that attaches to printer).

To locate the identification labels for the 7-bin Tabletop Mailbox, detach the accessory from the printer. The identification label is located on the bottom side of the back cover.

Specifications

This section contains information on physical and electrical characteristics of the printer. For information on the printer site and environmental requirements (such as operating temperature and humidity, ventilation, etc.), see Chapter 2.

Table 1-4. Printer and Accessory Dimensions

Item	Height	Width	Depth	Weight
Printer only	21.30 in. (541 mm)	46.75 in. (1187 mm)	20.50 in. (520 mm)	106 lbs. (48 kg) (without toner cartridge and with paper trays)
Printer with 2 x 500-sheet Input Tray or 2000-sheet Input Tray	40.20 in. (1021 mm)	46.75 in. (1187 mm)	20.50 in. (520 mm)	160-164 lbs. (72.6-74.4 kg)
Toner cartridge	n/a	n/a	n/a	¹ Full: 106 oz (3,000 g) Empty: 80.5 oz (2,200 g)
7-bin Tabletop Mailbox (LCO)	20.87 in. (530 mm)	6.70 in. (170 mm)	18.50 in. (470 mm)	30 lbs. (14 kg.)
2 x 500-sheet Input Tray (MIT)	18.89 in. (480 mm) Including Transfer Door: 25.59 in. (650 mm)	24.76 in. (629 mm)	20.47 in. (520 mm)	61 lbs. (27.9 kg.) without paper
2000-sheet Input Tray (HCI)	18.89 in. (480 mm) Including Transfer Door: 25.59 in. (650 mm)	24.76 in. (629 mm)	20.47 in. (520 mm)	65 lbs. (29.5 kg)

Table 1-4. Printer and Accessory Dimensions (continued)

Item	Height	Width	Depth	Weight
8-bin Multibin Mailbox	35.23 in. (895 mm)	17.12 in. (435 mm)	18.90 in. (480 mm)	42.32 lbs. (19.2 kg)
Stapler	14.17 in. (360 mm)	19.68 in. (500 mm)	14.56 in. (370 mm)	10.50 lbs. (4.8 kg)
Duplexer	37.40 in. (950 mm)	15.31 in. (389 mm)	16.73 in. (425 mm)	7.93 lbs. (3.6 kg)
Envelope Feeder	5.11 in. (130 mm)	15.31 in. (389 mm)	14.37 in. (365 mm)	7.71 lbs. (3.5 kg)
LCO Stand (only for the 7- bin Tabletop Mailbox)	18.90 in. (480 mmmm)	16.90 in. (430 mm)	18.90 in. (480 mm)	32.00 lb (14.5 kg)

1. Some toner will reside in the waste toner area of a toner cartridge when the toner supply is exhausted. Therefore toner cartridge weight may be an unreliable indication of remaining toner supply.

Table 1-5. Electrical Specifications

Volts	Frequency	Amps¹	Watts (average)
Printer			
120 Vac ± 10% 100 Vac ± 10%	50/60 Hz ± 2 Hz 50/60 Hz ± 2 Hz	13.5 @ 120v	printing = 500 standby= 135 PowerSave Mode LaserJet 8000 =21 LaserJet 8000 N=24
220 Vac ± 10% 240 Vac ± 10%	50 Hz ± 2 Hz 50 Hz ± 2 Hz	6.0 @ 220v	printing = 500 standby= 135 PowerSave Mode LaserJet 8000 =21 LaserJet 8000 N=24
2000-sheet Input Tray (Tray 4)			
120 Vac ± 10%	50/60 Hz ± 2 Hz	0.5 maximum 0.3 average	45 Watts Maximum
240 Vac ± 10%	50/60 Hz ± 2 Hz	0.3 maximum 0.2 average	45 Watts Maximum
Multibin Mailbox/Mailbox with Stapler			
100-240 Vac	50/60 Hz ± 2 Hz	0.5 @ 120v 0.25 @ 240v	45 Watts Maximum
2 x 500-sheet Input Tray (Trays 4 and 5)			
120 Vac ± 10%	50/60 Hz ± 2 Hz	0.9 maximum	47 Watts Maximum
240 Vac ± 10%	50/60 Hz ± 2 Hz	0.5 maximum	47 Watts Maximum
7-bin Tabletop Mailbox			
120 Vac ± 10%	50/60 Hz ± 2 Hz	0.5 maximum	28 Watts Maximum
240 Vac ± 10%	50/60 Hz ± 2 Hz	0.3 maximum	28 Watts Maximum

1. Operating current requirements.

Table 1-6. Acoustic Emissions

Operation position (per ISO 9296)		Printer (stand-alone)	Printer System¹
Printing	LPA dB(A)	54 db	56 db
Standby	LPA dB(A)	42 db	42 db
Bystander 1m (per ISO 9296)			
Printing	LPA dB(A)	50 db	55 db
Standby	LPA dB(A)	38 db	42 db
Sound Power (per ISO 9296)			
Printing	LWAD	6.6 bels (A)	7.1 bels (A)
Standby	LWAD	5.5 bels (A)	5.5 bels (A)

1. Printer System includes the 2000-sheet Input Tray (Tray 4) or 2 x 500-sheet Input Tray (Trays 4 and 5), Multibin Mailbox/ Mailbox with Stapler, Duplexer, and Envelope Feeder.

Media Selection Guidelines

Note

More detailed specifications are in the *HP LaserJet 8000, 8000 N, 8000 DN, and HP Mopier 240 Printers User Guide* and the *HP LaserJet Printer Family Paper Specification Guide*. See “Technical Assistance” on page 31.

Paper

To achieve the best possible print quality and avoid paper jams, follow these guidelines for selecting paper:

- 1 Use only copier grade paper that meets all specifications in the paper specification guide. Avoid paper with embossed lettering, perforations, or texture that is too smooth or too rough.
- 1 Colored paper should be of the same high quality as white photocopy paper. The pigments must withstand the fusing temperature of 392° F (200° C) for 0.1 second without deterioration. Do not use paper with a colored coating that was added after the paper was produced.
- 1 Pre-printed forms must be printed with non-flammable, heat-resistant inks that do not melt, vaporize, or release hazardous emissions when subjected to the fusing temperature of 392° F (200° C) for 0.1 second.
- 1 A small sample of a new print media should be tested before purchasing large quantities.

Envelopes

CAUTION

To prevent severe damage to the printer, do not use envelopes that have windows, clasps, snaps, or any non-paper materials.

Print Envelopes to the Left Output Bin only.

Envelopes can be printed from Tray 1 and from the optional Envelope Feeder. Choose envelopes that are well-constructed. They should lie flat and be sharply creased. They should not be wrinkled, nicked, or otherwise damaged. Envelope adhesive must be compatible with the heat and pressure of the fusing process.

Adhesive Labels

Use the following guidelines when selecting labels:

CAUTION

Tray 1 is required for printing adhesive labels.

Print labels to the Left Output Bin only.

This printer does not support use of labels with any exposed spaces.

Do not attempt to print on label sheets after any of the labels have been removed from the sheet. Damage to the printer may result.

- 1 Labels must be arranged on the carrier sheet so that there are no exposed spaces on the sheet. Using label stock with spaces between rows or columns of labels can often result in labels peeling off during printing, causing serious jamming and possible damage to the printer.
- 1 The top sheet (printing surface) must be of copier quality and provide good toner adhesion.
- 1 The carrier sheet (backing sheet) must be compatible with the temperature and pressure of the fusing process, and must be coated for easy release of the top sheet.
- 1 The adhesive must be stable at the 392° F (200° C) temperature encountered for 0.1 second in the fusing process, and must not produce emissions that exceed exposure levels or threshold limits established by OSHA and other safety agencies. Adhesives must not come into direct contact with any part of the printer.

A wide selection of suitable labels may be ordered through Hewlett-Packard. Available sizes are listed in the *HP LaserJet Printer Family Paper Specification Guide*.

Transparencies

CAUTION

Tray 1 is required for printing transparencies.

Print transparencies to the Left Output Bin only.

Transparencies used in HP LaserJet printers must be able to withstand the 392° F (200° C) temperature encountered in the printer's fusing process for 0.1 second. Suitable transparency film is available through Hewlett-Packard. See the *HP LaserJet Printer Family Paper Specification Guide* for details.

Storing Print Media

Follow these guidelines when stacking and storing print media:

- 1 Store paper in its wrapper until ready to use.
- 1 Re-wrap partially used packages of media before storing.
- 1 Stack each carton upright and squarely on top of the other.
- 1 Store envelopes in a protective box to avoid damaging the edges of the envelopes.
- 1 Keep stored media away from temperature and humidity extremes.
- 1 DO NOT store cartons or reams directly on the floor where they will absorb a higher moisture content. Instead, place cartons on a pallet or on shelves.
- 1 DO NOT store individual reams in a manner that causes them to curl or warp along the edges.
- 1 DO NOT stack more than six cartons on top of each other.
- 1 DO NOT place anything on top of media, regardless of whether the paper is packaged or unpackaged.
- 1 DO NOT store printed documents in vinyl folders (which may contain plasticizers) or expose the documents to petroleum-based solvents.

Shipping Print Media

When shipping print media through different environments, plastic wrap all cartons on the shipping pallet. When shipping media across bodies of water, wrap individual cartons as well. Packaging must protect the media from physical damage.

Product Overview

External View of HP LaserJet 8000/N/DN Engine

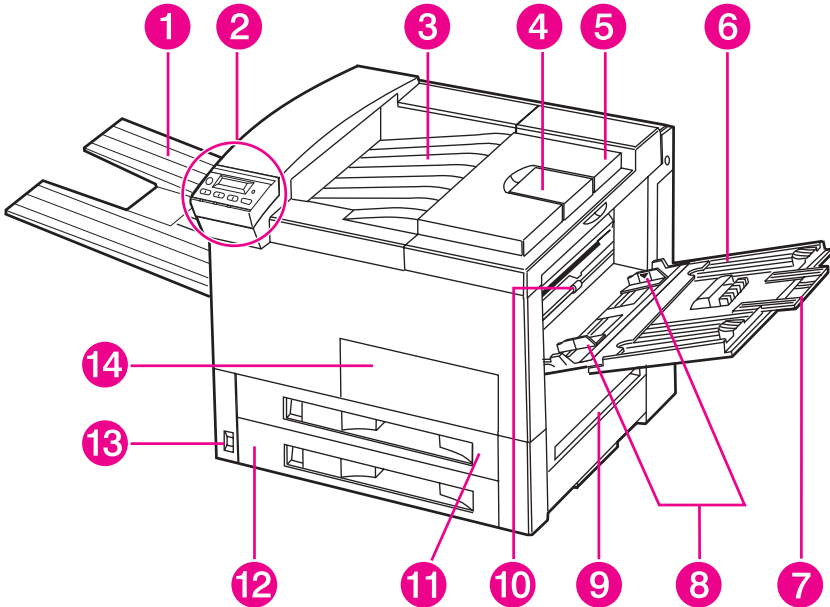

Figure 1-2 HP LaserJet 8000/N/DN Engine - Front and Right Side View with Tray 1 Open

- 1 Left Output Bin
- 2 Control Panel
- 3 Standard Output Bin
- 4 Adjustable Paper Stop
- 5 Top Cover
- 6 Tray 1
- 7 Tray 1 Extensions
- 8 Tray 1 Paper Width Guides
- 9 Input Slot for 2000-sheet Input Tray (Tray 4)
or 2 x 500-sheet Input Tray (Trays 4 and 5)

10 Tray 1 Pickup Roller

11 Tray 2

12 Tray 3

13 On/Off Switch

14 Front Access Door

Not shown:

- | Duplexer (internal)
- | 5-bin Mailbox with Stapler
- | 2 x 500-sheet Input Tray
- | 7-bin Tabletop Mailbox and stand
- | 2000-sheet Input Tray
- | Envelope Feeder
- | 8-bin Multibin Mailbox
- | Printer stand

Note

You will need a stand for the LCO if you have an input device or cabinet.

External View of HP Mopier 240

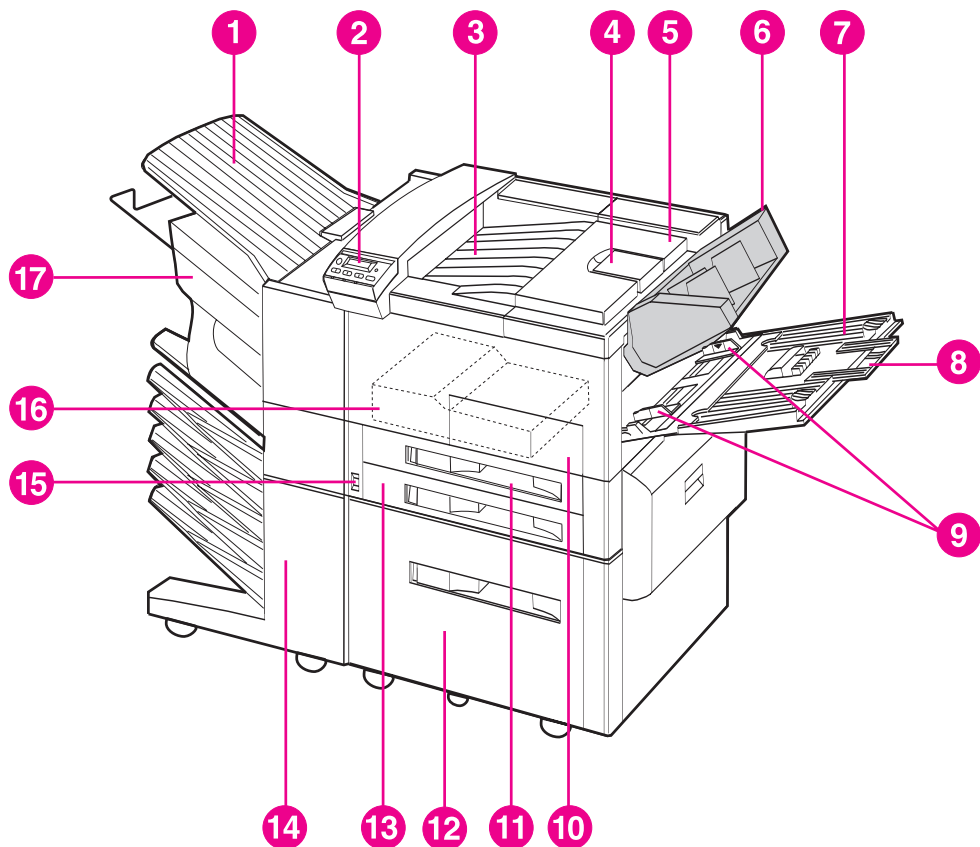

Figure 1-3 HP Mopier 240 - Front and Right Side View with Tray 1 Open

- 1 Left Output Bin
- 2 Control Panel
- 3 Standard Output Bin
- 4 Adjustable Paper Stop
- 5 Top Cover
- 6 Envelope Feeder (optional)
- 7 Tray 1 (multipurpose)
- 8 Tray 1 Extensions
- 9 Tray 1 Paper Width Guides
- 10 Front Door

- 11** Tray 2
- 12** 2000-sheet Input Tray (Tray 4)
(not shown) 2 x 500-sheet Input Tray (Trays 4 & 5)
- 13** Tray 3
- 14** 5-bin Mailbox with Stapler
- 15** On/Off Switch
- 16** Duplexer (internal)
- 17** Stapler

Formatter Assemblies

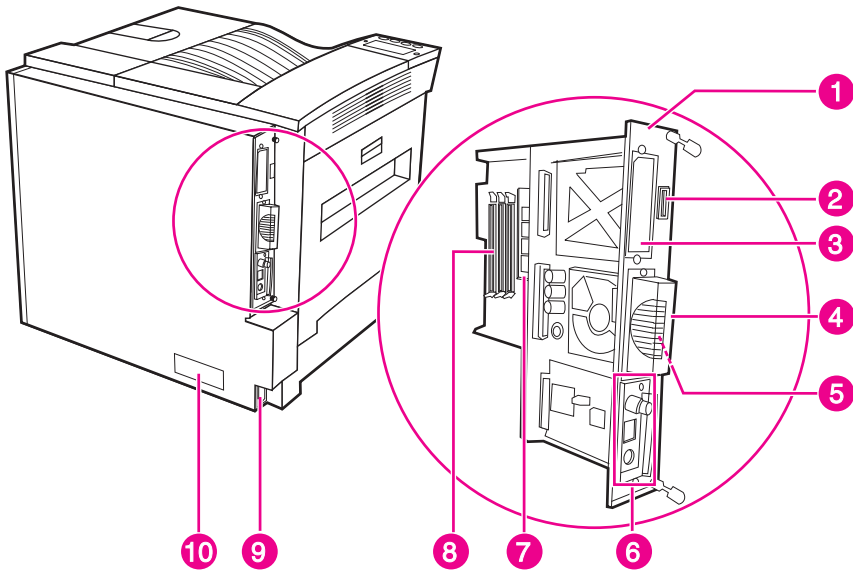

Figure 1-4 Rear and Left Side View

- 1 Formatter Pan Assembly
- 2 Parallel IEEE 1284 Interface Port
- 3 EIO Slot 3 Location
- 4 EIO Slot 2 Location [Hard Disk Accessory Location (optional for LJ 8000/N/DN and standard for HP Mopier 240)]
- 5 External Paper Handling Controller Port (behind EIO Slot 2/Hard Disk Accessory Location)
- 6 EIO Slot 1 Location
- 7 Firmware DIMM
- 8 DIMM Slots (3)
- 9 AC Power Connector
- 10 Model and Serial Number Label

Accessories and Options

The accessories and optional equipment for the HP LaserJet 8000, 8000 N, and 8000 DN printers is shown in figure 1-5 and described in table 1-7. For the HP Mopier 240 (C4228A), all the accessories in figure 1-5 and in table 1-7 are standard features, except for the Envelope Feeder and the Multibin Mailbox (replaced with the 5-bin Mailbox with Stapler).

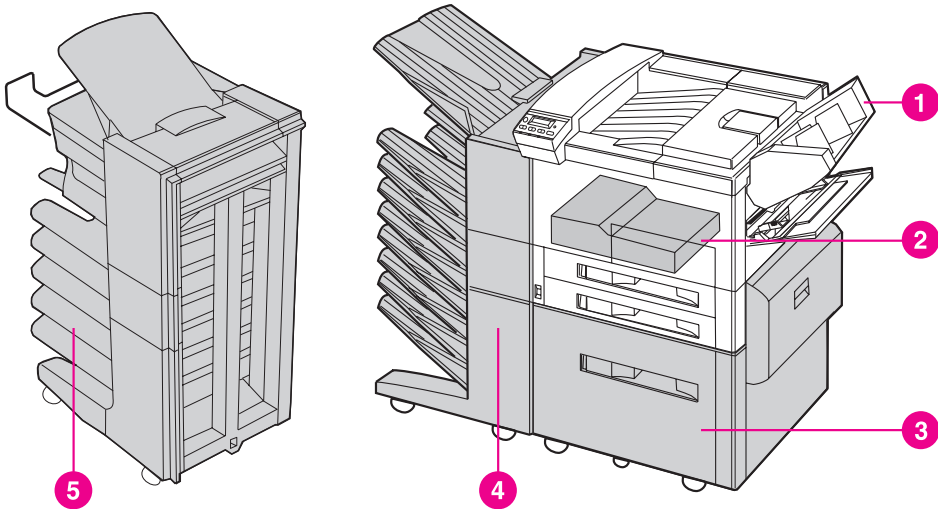

Figure 1-5 HP LaserJet 8000/N/DN Optional Paper Handling Accessories

- 1 Envelope Feeder
- 2 Duplexer (internal)
- 3 2000-sheet Input Tray (Tray 4)
(Not shown) 2 x 500-sheet Input Tray (Trays 4 and 5)
- 4 8-bin Mailbox (provides mailbox, job separation, and job stacking)
- 5 5-bin Mailbox with Stapler (provides mailbox, job separation, job stacking, collating and stapling)

Not shown:

- 1 8-bin Multibin Mailbox
- 1 7-bin Tabletop Mailbox

Ordering Information

Use only accessories specifically designed for this printer. To order an accessory, contact an HP-authorized service or support provider.

Table 1-7. Accessories and Options

	Item	Description or Use	Order Number
Paper Handling	2 x 500-sheet Input Tray	Two 500-sheet trays and feeder.	C4780A
	2000-sheet Input Tray	One 2000-sheet tray and feeder.	C4781A
	Tray 2 (500-sheet Input) or Tray 4 (2 x 500-sheet Input Tray)	Holds 500 sheets; adjustable for Letter, Legal, ISO A4, JISB4	C4098A
	Tray 3 (500-sheet Input) or Tray 5 (2 x 500-sheet Input Tray)	Holds 500 sheets; adjustable for Letter, Legal, Ledger (11 x 17), ISO A4, ISO A3, JISB4	C4099A
	Envelope Feeder	Automatically feeds up to 100 envelopes.	C3765B
	Duplex Printing Accessory (duplexer)	Allows automatic printing on both sides of paper.	C4782A
	7-bin Tabletop Mailbox	Each of the 7 face-down output bins holds 120 sheets of paper. One face-up output bin holds 100 sheets of paper. Designed for tabletop use.	C4783A
	Multibin Mailbox	Each of the 8 output bins holds 250 sheets of paper.	C4785A
	5-bin Mailbox with Stapler	Each of the 5 output bins holds 250 sheets of paper. Provides job separation by stapling jobs.	C4787A

Table 1-7. Accessories and Options (continued)

Item	Description or Use	Order Number
Printer Stands Printer Stand	Used in place of the 2000-sheet Input Tray (Tray 4) or the 2 x 500-sheet Tray (Trays 4 and 5) when a mailbox accessory is attached.	C2975A
Stand for 7-bin Tabletop Mailbox	Allows 7-bin Tabletop Mailbox to be used when printer is mounted on 2 x 500-sheet Input Tray, 2000-sheet Input Tray, or printer stand.	C4784A

Table 1-7. Accessories and Options (continued)

	Item	Description or Use	Order Number
Printing Supplies	HP Multipurpose Paper (Other HP media is available where office products are sold.)	HP brand paper for a variety of uses (1 box of 10 reams, 500 sheets each). To order a sample, in the U.S. call 1-800-471-4701.	HPM1120
	HP LaserJet Paper (Other HP media is available where office products are sold.)	Premium HP brand paper for use with HP LaserJet printers (1 box of 10 reams, 500 sheets each). To order a sample, in the U.S. call 1-800-471-4701.	HPJ1124
	Toner Cartridge (15,000 pages)	Replacement HP Microfine toner cartridge.	C3909A
	Toner Cartridge (15,000 pages)	3 Replacement HP Microfine toner cartridges for the HP Mopier 240.	C3909S

Table 1-7. Accessories and Options (continued)

Item	Description or Use	Order Number		
Memory, Fonts, and Mass Storage	Dual In-line Memory Module (DIMM) (100-pin)	Boosts the ability of the printer to handle large print jobs (maximum 192 MB with HP brand DIMMs).		
	EDO DIMMs (100-pin)	4 MB 8 MB 16 MB	C4135A C4136A C4137A	
	SDRAM DIMMs (100-pin)	4 MB 8 MB 16 MB 32 MB 64 MB	C4140A C4141A C4142A C4143A C3913A	
	Flash DIMM (100-pin)	Permanent storage for fonts and forms:		
		2 MB 4 MB	C4286A C4287A	
	Font DIMM (100-pin)	8 MB Asian ROM: traditional Chinese simplified Chinese Korean	C4292A C4293A D4838A	
	Hard Disk	Permanent storage for fonts and forms (1.4 MB maximum storage for fonts). Enables Raster Image Processor (RIP) ONCE mopying of print jobs that are too large to RIP ONCE mopy in RAM.	C2985A	
	Cable and Interface Accessories	Parallel Cables	3 Meter IEEE-1284 cable 10 Meter IEEE-1284 cable	C2946A C2947A
		Macintosh Network Cable Kit	For PhoneNET or LocalTalk connection.	92215N

Table 1-7. Accessories and Options (continued)

	Item	Description or Use	Order Number
Cable and Interface Accessories	Enhanced I/O Cards	HP JetDirect print server multi-protocol EIO network cards: Ethernet (RJ-45 only) Ethernet (RJ-45 and BNC) and LocalTalk Token Ring (RJ-45 and DB-9) Fast Ethernet 10/100Base-TX (RJ-45 only)	J3110A J3111A J3112A J3113A
	Power Box	For connecting a multibin mailbox to the printer when the printer is on a printer stand. This item is included with the 2000-sheet Input Tray and the 2 x 500-sheet Input Tray.	C4789A
Maintenance Accessory	Preventive Maintenance Kit	For 110V units	C3971B
		For 220V units	C3971-69002 C3972B C3972-69002
Documentation	<i>HP LaserJet Printer Family Paper Specification Guide</i>	A guide to using paper and other print media with HP LaserJet printers.	5010-8956
	<i>HP JetDirect Print Server Software Installation Guide</i>	A guide to installing and using the JetDirect Print Server software with HP LaserJet printers. Contains information for multiple operating systems.	J2552-90051
	<i>PCL 5/PJL Technical Reference Documentation Package</i>	A guide to using printer commands with HP LaserJet printers.	5021-0377
Documentation	<i>HP LaserJet 8000, 8000 N, 8000 DN, and HP Mopier 240 Printers User Guide</i>	This is an online user guide provided on compact disc.	C4085-60101

Table 1-7. Accessories and Options (continued)

Item	Description or Use	Order Number
<i>HP LaserJet 8000, 8000 N, 8000 DN, and HP Mopier 240 Printers Getting Started Guide</i>	An additional copy of the getting started guide.	C4085-90901 (English)
<i>HP LaserJet 8000, 8000 N, 8000 DN, and HP Mopier 240 Printers Ready Reference Guide</i>	An additional copy of the ready reference guide.	C4085-90921 (English)
User Documentation Bundle	An additional copy of the getting started guide and the ready reference guide.	C4085-90941 (English)
<i>HP LaserJet 8000, 8000 N, 8000 DN, and HP Mopier 240 Printers Service Manual</i>	An additional copy of the service manual.	C4085-91017
Service Documentation Bundle	An additional copy of the service manual and <i>HP LaserJet 8000, 8000 N and 8000 DN Printers Service Manual Supplement for Paper-handling Accessories</i>	C4085-99021 (English)

Hard Disk

The printer hard disk accessory is optional for the HP LaserJet 8000/N/DN printers. The hard disk is a standard feature of the HP Mopier 240. It can be used to permanently store downloaded fonts and forms in the printer. Unlike the standard printer memory, permanently downloaded items remain in the printer even when the printer is powered off.

Fonts downloaded to the hard disk are available to all users of the printer.

Macintosh users can use the HP LaserJet Utility, and Windows® users can use the HP printer driver to download fonts. The printer hard disk can also be write-protected through software for additional security. See the online help associated with your HP software for more information.

If you are a PostScript language programmer, see Adobe's™ PostScript Language Reference Manual for information about downloading forms and patterns to the disk. (For the Macintosh environment, see the online help in the HP LaserJet Utility Guide included with the HP LaserJet Utility software.) For the Windows environment, see your HP Windows driver online help.

Determining Memory Requirements

The amount of memory you need depends on the types of documents you print. With the PCL printer language, the printer can print most text and graphics at 300 or 600 dpi without additional memory.

Add memory to your printer if you

- 1 Commonly print complex graphics.
- 1 Use many downloaded fonts.
- 1 Print complex documents.
- 1 Use advanced functions (such as I/O Buffering and Resource Saving).

For the HP LaserJet 8000 printer, you can add up to 3 x 64 MB DIMMS of memory for a total of 192 MB. If you have the HP LaserJet 8000 DN printer or HP Mopier 240, you can add up to 64 MB of additional memory for a total of 192 MB.

Table 1-8 presents the amount of memory required for the most common print jobs performed with the HP LaserJet 8000/N/DN and HP Mopier 240 using 600-dpi printing.

Table 1-8. Minimum Memory Requirements

Print Job	Paper Size	PCL Minimum Memory Requirements	PostScript Emulation Minimum Memory Requirements
single-sided printing	Letter, A4, Legal	16 MB	16 MB
	11 x 17 in, A3	16 MB	16 MB
two-sided printing	Letter, A4	16 MB	16 MB
	Legal	16 MB	16 MB
	11 x 17 in, A3	16 MB	16 MB

Service Approach

Repair of the printer normally begins with a three-step process:

- 1 Step 1: Isolate the problem to the major system, i.e. the host computer, the network and/or server, or the printer system.
- 1 Step 2: Determine if the problem is located in the accessories or in the printer engine.
- 1 Step 3: Troubleshoot the problem using the procedures in Chapter 7.

Once a faulty part is located, repair is usually accomplished by assembly level replacement of Field Replaceable Units (FRUs). Some mechanical assemblies may be repaired at the subassembly level. Replacement of components on the printed circuit assemblies is not supported by Hewlett-Packard.

Ordering Parts

Field replaceable part numbers are listed in Chapter 8 of this manual. Replacement parts may be ordered from HP's Support Materials Organization (SMO), or Support Materials Europe (SME).

Phone numbers

SMO (Support Materials Organization)

1-800-227-8164 (U.S. Only)

SME (Support Materials Europe)

(49 7031) 142253

HP's Distribution Center (HPD)

1-303-353-7650

HP Support Line

1-800-633 - 3600

Exchange Program

HP offers remanufactured assemblies for some parts. These are identified in Chapter 8 and can be ordered through Parts Direct Ordering (PDO), Support Materials Organization (SMO), or Support Materials Europe (SME).

Consumables

The printer has two consumables; the toner cartridge and staple cartridges, which may be ordered directly from Hewlett-Packard. See Chapter 8 for ordering information.

Toner Cartridge Life

The Toner Cartridge (C3909A) is designed to simplify replacement of the major “consumable” parts. The toner cartridge contains the printing mechanism and a supply of toner. HP Mopier 240 cartridges (C3909S) are packaged in groups of three.

At 5% page coverage, a toner cartridge is guaranteed to print approximately 15,000 images (see figure 1-6).

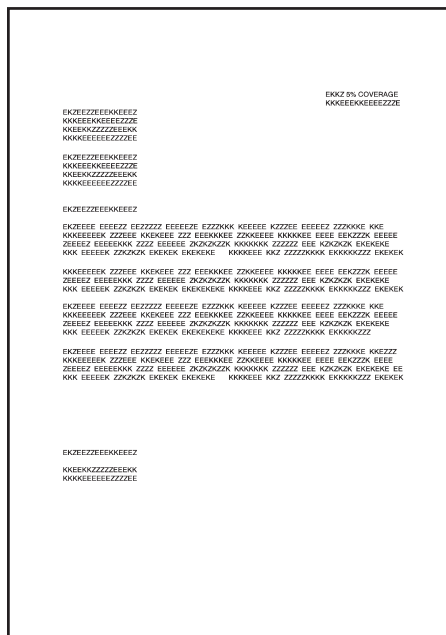

Figure 1-6

Sample 5% Page Coverage

The toner cartridge may print less than 15,000 images if routinely printing very dense print. Conversely, when routinely printing pages with less coverage (such as short memos), or in EconoMode, the toner cartridge may print more than 15,000 images. However, EconoMode does not extend toner cartridge component life.

Note

For best results, always use a new toner cartridge before the expiration date stamped on the toner cartridge box.

Refilled Toner Cartridges & Non-HP Staple Cartridges

While Hewlett-Packard does not prohibit the use of refilled toner cartridges and non-HP staple cartridges during the warranty period or while under a maintenance contract, their use is not supported for the following reasons:

- 1 Repairs resulting from the use of refilled toner cartridges and non-HP staple cartridges are not covered under the Hewlett-Packard warranty or maintenance contract.
- 1 Hewlett-Packard has no control or process to ensure that a refilled toner cartridge or non-HP staple cartridge functions at the high level of reliability of a new HP LaserJet toner cartridge or HP LaserJet staple cartridge. Also, Hewlett-Packard cannot predict the long term reliability effect on the printer when using different toner formulations found in refilled cartridges.
- 1 The print quality of HP LaserJet toner cartridges influences the customer's perception of the printer. Hewlett-Packard has no control over the actual print quality of a refilled toner cartridge.

Recycling Toner Cartridges

In order to reduce waste, Hewlett-Packard uses a recycling program for used toner cartridges. Cartridge components that do not wear out are recycled, as are plastics and other materials. Hewlett-Packard pays the shipping costs from the user to the recycling plant. For each cartridge returned, HP donates one U.S. dollar to be shared by the Nature Conservancy and the National Wildlife Federation. To join this recycling effort, follow the instructions inside the toner cartridge box.

Technical Assistance

HP ASAP (Automated Support Access Program) provides free technical support information 24 hours a day, 7 days a week. The ASAP system includes HP FIRST, explained below. The ASAP service requires a touchtone phone.

HP FIRST (Fax Information Retrieval Support Technology)

HP FIRST (Fax Information Retrieval Support Technology) is a phone-in fax service providing technical information for HP LaserJet users as well as service personnel. Receiving a fax requires a type 3 facsimile machine or fax card. Service related information includes:

- | Service notes (HP Authorized dealers)
- | Application notes
- | Product Data Sheets
- | Material Safety Data Sheets (MSDS)
- | Typeface and accessory information
- | Printer support software information
- | Toner information
- | Driver request form and Software Matrix.

HP FIRST, U.S.

Call the HP ASAP system (1-800-333-1917) and follow the voice prompts to enter HP FIRST.

HP FIRST, Europe

Call HP FIRST at one of the following numbers:

- | U.K., 0800-96-02-71
- | Belgium (Dutch), 078-11-19-0
- | Switzerland (German), 155-1527
- | Netherlands, 06-02-22-420
- | Germany, 0130-810061
- | Austria, 0660-8128

For English service outside the above countries, (31) 20-681-5792.

HP CompuServe Forum

CompuServe™ members can download a variety of support materials including product data sheets, software application notes, and printer drivers for many popular software applications. Members may also post and reply to questions in an interactive format. To access the HP Forum, type GO HP at any prompt. For more information, or to join CompuServe, call 1-800-524-3388.

Internet

Anonymous FTP library service is available for around-the-clock access to drivers, software, and technical support information for HP peripheral and computer products. Please note that paths may change without notice. Access the Internet or FTP address and use the menus to locate the software or support of your choice.

URL for Access HP: <http://www.hp.com>

URL for Software and Support: <http://www.hp.com/go/cposupport>

FTP address: <ftp.hp.com>

Login: anonymous

Password: your Internet name (or user identification)

FTP Path for Drive Software: `/pub/printers`

FTP Path for Network Software: `/pub/networking`

World Wide Web

Download printer driver software using www.hp.com/cposupport/eschome.html.

HP Reseller Sales and Service Support Line

The Hardware Technical Support Center (HTSC) is available for technical support to assist Hewlett-Packard authorized service technicians. The HTSC can be reached at 1-800-544-9976 between 7:00 A.M. and 6:00 P.M. Mountain Standard Time, Monday, Tuesday, Thursday, and Friday. On Wednesdays the office closes at 4:00 P.M.

Other Areas

Outside of North America and Europe, contact your local HP sales office for assistance in obtaining technical support.

Warranty

This warranty entitles you to standard warranty services for your printer and accessories and is available from HP worldwide. However, there may be local variations in the level of warranty service. You should contact the local HP Service Center to check for the applicable local warranty in your country or province.

One-Year On-Site Limited Warranty

Hewlett-Packard warrants its computer hardware products against defects in materials and workmanship for a period of one year from purchase by the end user. During the warranty period, HP will, at its option, either repair or replace products which prove to be defective.

The warranty period begins either on the date of delivery or, where the purchase price includes installation by Hewlett-Packard, on the date of installation.

Should HP be unable to repair or replace the product within a reasonable amount of time, you will be entitled to a refund of the purchase price if you return the product.

To have your printer serviced by HP you should contact the closest HP Service Center.

Exclusions

The warranty on your HP LaserJet 8000/N/DN family printer shall not apply to defects resulting from:

- 1 Improper or inadequate maintenance by customer.
- 1 Customer supplied software or interfacing.
- 1 Unauthorized modification or misuse.
- 1 Operation outside of the environmental specifications for the product.
- 1 Operation of non-supported printing media.
- 1 Duty cycle abuse maximum (see the note on the following page).
- 1 Using a mechanical switchbox with the printer without a designated surge protector.
- 1 Improper site preparation and maintenance.
- 1 Failure to perform key operator maintenance every 350,000 images.
- 1 Use of non-HP toner cartridges (see the following explanation), memory boards, or interface boards.

Note

The use of non-Hewlett-Packard toner cartridges alone does not affect either your warranty or any maintenance contract you may have purchased. However, if an HP LaserJet printer failure or damage is found to be attributable directly to the use of a non-HP toner cartridge, HP will not repair the printer free-of-charge. In this case, standard time-and-materials charges will be applied to service your printer for that particular failure or damage.

Operation of the printer beyond the limit of its duty cycle (printing greater than the equivalent of 130,000 images per month) shall be deemed printer abuse and all repairs thereafter will be billed on a time-and-materials basis.

If you are using a mechanical switch box, ensure that it is equipped with a surge protector. Damage to your printer could occur from the use of unprotected mechanical switch boxes.

Warranty Limitations

The warranty set forth above is exclusive and no other warranty, whether written or oral, is expressed or implied. Hewlett-Packard specifically disclaims the implied warranties of merchantability and fitness for a particular purpose.

Service During the Warranty Period

If your hardware should fail during the warranty period, contact an authorized HP dealer or an HP Customer Service Center.

Service After the Warranty Period

If your hardware fails after the warranty period, contact an authorized HP dealer or your local Customer Service Center. If you have an HP Maintenance Agreement, request service under your agreement.

Regulatory Information

FCC Regulations

This equipment has been tested and found to comply with the limits for a Class B digital device, pursuant to Part 15 of the FCC rules. These limits are designed to provide reasonable protection against harmful interference in a residential installation. This equipment generates, uses, and can radiate radio frequency energy. If this equipment is not installed and used in accordance with the instructions, it may cause harmful interference to radio communications. However, there is no guarantee that interference will not occur in a particular installation. If this equipment does cause harmful interference to radio or television reception, which can be determined by turning the equipment off and on, the user is encouraged to try to correct the interference by one or more of the following measures:

- 1 Reorient or relocate the receiving antenna.
- 1 Increase separation between equipment and receiver.
- 1 Connect equipment to an outlet on a circuit different from that to which the receiver is located.
- 1 Consult your dealer or an experienced radio/TV technician.

Note

Any changes or modifications to the printer that are not expressly approved by HP could void the user's authority to operate this equipment.

Use of a shielded interface cable is required to comply with the Class B limits of Part 15 of FCC rules.

Environmental Product Stewardship

Protecting the Environment

Hewlett-Packard Company is committed to providing quality products in an environmentally-sound manner. The printer has been designed to minimize impacts on the environment.

The printer design eliminates:

Ozone Production

The printer uses charging rollers in the electrophotographic process and therefore generates no appreciable ozone gas (O_3).

CFC Usage

Class I U.S. Clean Air Act stratospheric ozone-depleting chemicals (chlorofluorocarbons [CFCs], for example) have been eliminated from the manufacturing of the printer and packaging.

The printer design reduces:

Energy Consumption

Energy usage drops from 500/505 (110V/220V units) watts (W) during printing to as little as 35/40 (110V/220V units) W while in low-power (Power Save) mode. This saves energy without affecting the high performance of the printer. This product qualifies for the ENERGY STAR Program (U.S. and Japan). ENERGY STAR is a voluntary program established to encourage the development of energy-efficient office products. The ENERGY STAR name is a registered service mark of the U.S. Environmental Protection Agency.



As an ENERGY STAR partner, Hewlett-Packard Company has determined that this product meets ENERGY STAR Guidelines for energy efficiency.

Toner Consumption

EconoMode uses about 50% less toner, thereby extending the life of the toner cartridge.

Paper use

The printer's optional duplexing feature, which provides for two-sided printing, reduces paper usage and the resulting demands on natural resources.

The design of the printer facilitates the recycling of:

Plastics

Plastic parts have material identification markings, according to international standards, which enhance the ability to identify plastics for proper disposition at the end of the printer's life.

HP Toner Cartridges

In many countries, this product's toner cartridge/drum can be returned to HP using the prepaid shipping label and instructions included inside each new HP Toner Cartridge box. If your country is not listed in the recycling guide, call your local HP Sales and Service Office for further instructions.

HP Cartridge Recycling Program information:

Since 1990, the HP LaserJet Toner Cartridge Recycling Program has collected more than twelve million cartridges that otherwise may have been discarded into landfills. Once a cartridge is returned, it is disassembled and reusable components are cleaned and inspected for quality conformance. After passing strict inspection procedures, materials such as nuts, screws, and clips are reclaimed and used to produce new cartridges. Remaining materials are melted down and used as raw materials for a variety of other products. Over 95 percent (%) of the weight of returned materials is recycled. For more information in the U.S., call (1) (800) 340-2445 or contact the HP LaserJet Supplies Website at <http://ljsupplies.com/planetpartners>. Non-US customers can call the local HP Sales and Service Office for further information regarding the HP Toner Cartridge Recycling Program.

Paper

The printer is suited for the use of recycled papers when the paper meets the guidelines outlined in the *HP LaserJet Printer Family Paper Specifications Guide*.

To ensure printer longevity, HP provides the following:

Extended Warranty

HP SupportPack covers the printer and all HP-supplied internal components. It is a three-year warranty from the date of purchase. HP SupportPack must be purchased by the customer within 30 days of product purchase. Information on HP SupportPack is available by calling your local HP FIRST number.

Spare Parts and Consumables Availability

Spare parts and consumable supplies for this product will be made available for at least five years after production has stopped.

Material Safety Data Sheet

The Toner Cartridge/Drum MSDS can be obtained by calling the U.S. HP FIRST (Fax Information Retrieval Support Technology) at (1) (800) 231-9300. Use Index number 7 for a listing of the Toner Cartridge/Drum Material/Chemical Safety Data Sheets. Non-U.S. customers should refer to the HP Support pages at the front of this user guide for appropriate phone numbers and information. For more information in the U.S., call (1) (800) 340-2445 or contact the HP LaserJet Supplies Website at <http://ljsupplies.com/planetpartners>

Environmental Conformity

Plastics

Plastic parts have material identification markings, according to international standards, which enhance the ability to identify plastics for proper disposition at the end of the printer's life. The plastics used in the printer housing and chassis are technically recyclable.

Printer and Parts

Design for recycling has been incorporated into the printer and its accessories. The number of materials has been kept to a minimum while ensuring proper functionality and high product reliability. Dissimilar materials have been designed to separate easily. Fasteners and other connections are easy to locate, access, and remove with common tools. High priority parts have been designed to be accessed quickly for efficient disassembly and repair. Plastic parts have been primarily designed in two colors to enhance recycling options. A few small parts are colored specifically to highlight customer access points.

HP disposes of returned products in an environmentally sound manner. Many of the functional parts are recovered, tested, and reused as fully-warrantied service parts. Used printer parts are not placed into new product manufacturing. The remainder of the product parts are recycled, if possible. For product take-back information, contact your local HP Sales and Service Office.

Paper

The printer is suited for the use of recycled papers when the paper meets the guidelines outlined in the *HP LaserJet Printer Family Paper Specifications Guide*. The printer is suited for the use of recycled paper according to DIN 19 309.

Acoustics

It is advisable to place printers with a sound power level of L_{wad} of 6.3 Bel (A) or higher into a separate or divided up room.

Declaration of Conformity

according to ISO/IEC Guide 22 and EN45014

Manufacturer's Name: Hewlett-Packard Company

Manufacturer's Address: 11311 Chinden Boulevard

Boise, Idaho 83714-1021, USA

declares, that the product

Product Name: HP LaserJet 8000, 8000 N, 8000 DN, HP Mopier 240

Model Numbers: C4085A, C4086A, C4087A, C4228A

Product Options: ALL

conforms to the following Product Specifications:

Safety: IEC 950:1991+A1+A2+A3 / EN 60950:1992+A1+A2+A3

IEC 825-1:1993 / EN 60825-1:1994 Class 1 (Laser/LED)

EMC: CISPR 22:1993+A1 / EN 55022:1994 Class B ¹⁾

CISPR 22:1993+A1 / EN 55022:1994 Class A

EN 50082-1:1992

IEC 801-2:1991 / prEN 55024-2:1992 - 4 kV CD, 8 kV AD

IEC 801-3:1984 / prEN 55024-3:1991 - 3 V/m

IEC 801-4:1988 / prEN 55024-4:1992 - 0.5 kV Signal Lines

FCC Title 47 CFR, Part 15 Class B²⁾ / ICES-003, Issue 2 / VCCI-B¹⁾

AS / NZS 3548:1992 / CISPR 22:1993 Class B¹⁾

Supplementary Information:

The product herewith complies with the requirements of the following Directives and carries the CE-marking accordingly:

the EMC directive 89/336/EEC

the Low Voltage Directive 73/23/EEC

The product was tested in a typical configuration with Hewlett-Packard Personal Computer Systems.

This Device complies with Part 15 of the FCC Rules. Operation is subject to the following two conditions: (1) this device may not cause harmful interference, and (2) this device must accept any interference received, including interference that may cause undesired operation.

This printer contains Local Area Network (LAN) options. When the Interface Cable is attached to either of the IEEE 802.3 connectors, the printer meets the requirements of EN 55022 Class A.

January 15, 1997

For Compliance Information ONLY, contact:

Australia Contact: Product Regulations Manager, Hewlett-Packard Australia Ltd.,
31-41 Joseph Street, Blackburn, Victoria 3130, Australia

European Contact: Your Local Hewlett-Packard Sales and Service Office or Hewlett-Packard GmbH, Department HQ-TRE / Standards Europe,
Herrenberger Straße 130, D-71034 Böblingen (FAX: +49-7031-14-3143)

USA Contact: Product Regulations Manager, Hewlett-Packard Company, PO
Box 15 Mail Stop 160, Boise, ID 83707-0015 (Phone: 208-396-6000)

Safety Statements

Laser Safety Statement

The Center for Devices and Radiological Health (CDRH) of the U.S. Food and Drug Administration has implemented regulations for laser products manufactured since August 1, 1976. Compliance is mandatory for products marketed in the United States. The printer is certified as a “Class 1” laser product under the U.S. Department of Health and Human Services (DHHS) Radiation Performance Standard according to the Radiation Control for Health and Safety Act of 1968. Since radiation emitted inside the printer is completely confined within protective housings and external covers, the laser beam cannot escape during any phase of normal user operation.

WARNING!

Using controls, making adjustments, or performing procedures other than those specified in this user's guide may result in exposure to hazardous radiation.

Canadian DOC Regulations

Complies with Canadian EMC Class B requirements.

<<Conforme à la classe B des normes canadiennes de compatibilité électromagnétiques. << CEM>>.>>

VCCI Statement (Japan)

この装置は、情報処理装置等電波障害自主規制協議会（VCCI）の基準に基づく第二種情報技術装置です。この装置は、家庭環境で使用することを目的としていますが、この装置がラジオやテレビジョン受信機に近接して使用されると、受信障害を引き起こすことがあります。

取り扱い説明書に従って正しい取り扱いをして下さい。

Korean EMI statement

사용자 안내문 (B급 기기)

이 기기는 비업무용으로 전자파장해검정을 받은 기기로서, 주거지역에서는 물론 모든 지역에서 사용할 수 있습니다.

Laser Statement for Finland

LASERTURVALLISUUS

LUOKAN 1 LASERLAITE

KLASS 1 LASER APPARAT

HP LaserJet 8000, 8000 N, 8000 DN -laserkirjoitin on käyttäjän kannalta turvallinen luokan 1 laserlaite. Normaalisissa käytössä kirjoittimen suojakotelointi estää lasersäteen pääsyn laitteen ulkopuolelle.

Laitteen turvallisuusluokka on määritetty standardin EN 60825-1 (1993) mukaisesti.

VAROITUS !

Laitteen käyttäminen muulla kuin käyttöohjeessa mainitulla tavalla saattaa altistaa käyttäjän turvallisuusluokan 1 ylittävälle näkymättömälle lasersäteilylle.

VARNING !

Om apparaten används på annat sätt än i bruksanvisning specificerats, kan användaren utsättas för osynlig laserstrålning, som överskrider gränsen för laserklass 1.

HUOLTO

HP LaserJet 8000, 8000 N, 8000 DN -kirjoittimen sisällä ei ole käyttäjän huollettavissa olevia kohteita. Laitteen saa avata ja huoltaa ainoastaan sen huoltamiseen koulutettu henkilö. Tällaiseksi huoltotoimenpiteeksi ei katsota väriainekasetin vaihtamista, paperiradan puhdistusta tai muita käyttäjän käsikirjassa lueteltuja, käyttäjän tehtäväksi tarkoitettuja ylläpitotoimia, jotka voidaan suorittaa ilman erikoistyökaluja.

VARO !

Mikäli kirjoittimen suojakotelo avataan, olet alttiina näkymättömälle lasersäteilylle laitteen ollessa toiminnassa. Älä katso säteeseen.

VARNING !

Om laserprinterns skyddshölje öppnas då apparaten är i funktion, utsätts användaren för osynlig laserstrålning. Betrakta ej strålen.

Tiedot laitteessa käytettävän laseriodin säteilyominaisuuksista:

Aallonpituus 770-795 nm

Teho 5 mW

Luokan 3B laser

2 Site Requirements

Chapter Contents

Operating Environment- - - - -	-46
Space Requirements- - - - -	-47
Environmental Requirements- - - - -	-49

Operating Environment

The electrical specifications listed in Chapter 1 must be maintained to ensure proper operation of this printer. Consider the following points before installing the printer.

- Install the printer in a well-ventilated, dust-free area, away from any open windows.
- Install the printer on a hard, flat and continuous surface, with all four printer feet level. Do not install on carpet or other soft surfaces.
- Ensure adequate, stable power is supplied. Printer power requirements are listed in table 1-5, “Electrical Specifications,” on page 9.
- Install the printer where there is stable temperature and humidity, away from water sources, humidifiers, air conditioners, refrigerators, or other major appliances (see table 2-1 on page 49).
- Install the printer away from direct sunlight, open flames, or ammonia fumes. If the printer is placed near a window, make sure the window is closed and has a curtain or blind to block any direct sunlight.
- Install the printer with enough space around the printer for proper access and ventilation (see figure 2-1 on page 47).
- Install the printer away from the direct flow of exhaust from air ventilation, heating, or air conditioning systems.

Space Requirements

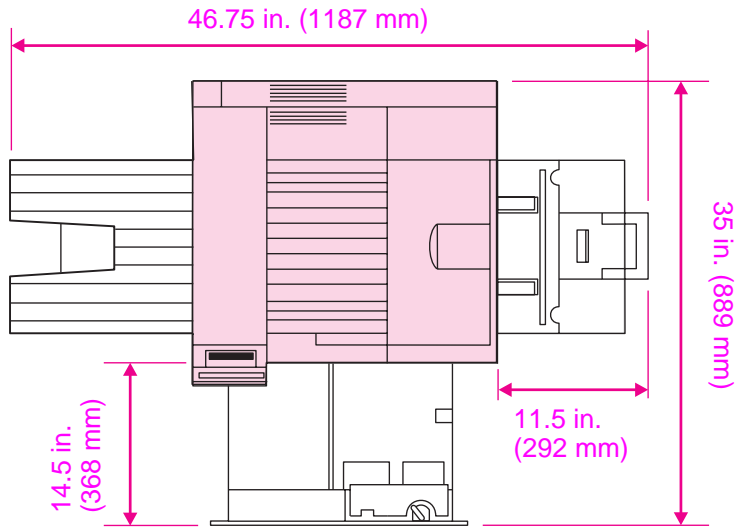

Figure 2-1 Printer Space Requirements (Top view)

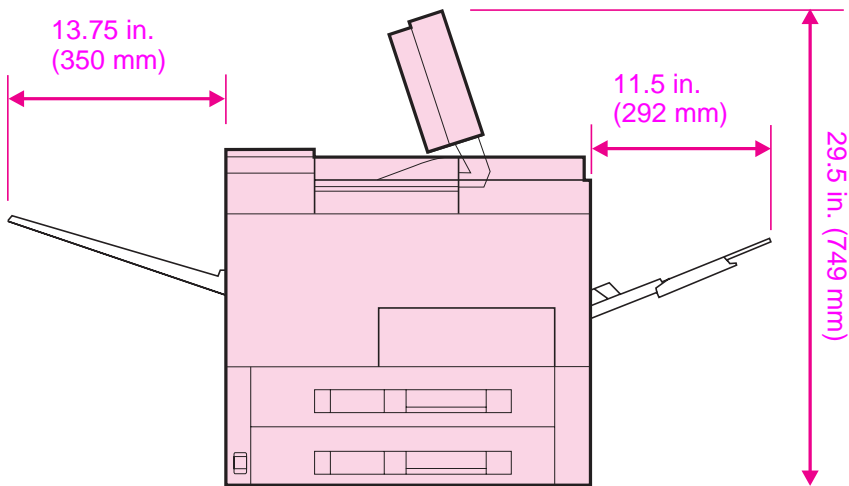

Figure 2-2 Printer Space Requirements (Side view)

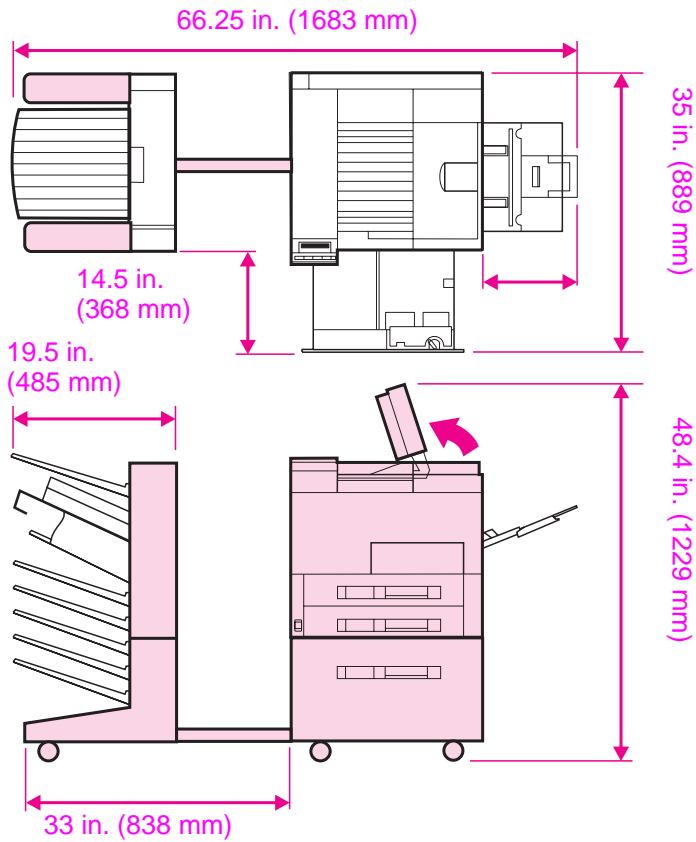

Figure 2-3 Printer Space Requirements (with Multibin Mailbox and Input Device)

Environmental Requirements

Keep the printer within the following environmental conditions for optimum performance.

Table 2-1. Printer and Toner Cartridge Environmental Conditions

	Operating	Storage
Temperature	10° to 32.5° C (50° to 90.5° F)	0° to 40° C (32° to 105° F)
Humidity	20 to 80% RH (with no condensation)	15 to 90% RH (with no condensation)

For printer weights, see table 1-4, "Printer and Accessory Dimensions," on page 7.

3 Operating Overview

Chapter Contents

Using the Control Panel - - - - -	-52
Resetting the Printer - - - - -	-55
Control Panel Menus- - - - -	-58
Service Mode - - - - -	-75
Testing the Printer - - - - -	-80
Cold Reset- - - - -	-85

Using the Control Panel

Control Panel Layout

The control panel contains a 2-line, 16-character-per-line display panel, six keys, and three indicator lights.

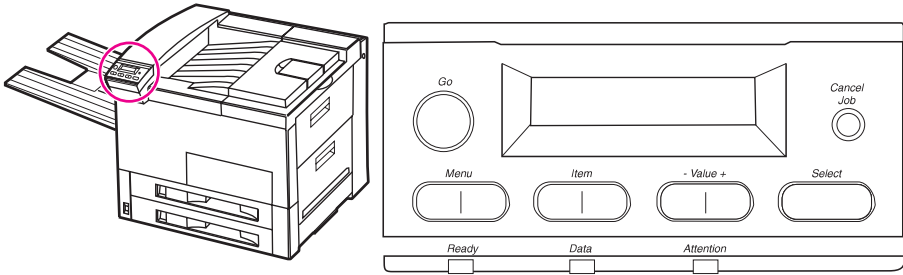

Figure 3-1 Control Panel Layout

Table 3-1. Control Panel Keys

Key	Function
Go	Switches the printer online or offline. Stops printing when memory clears.
MENU	Provides a menu system for obtaining status information or changing the printer configuration.
ITEM	Cycles through the items on the selected menu. Menu items that appear depend on the options installed and the configuration of other menu choices.
-VALUE+	Steps through the item choices.
SELECT	Selects a desired menu item; an asterisk (*) indicates the selected item.
CANCEL JOB	Allows the user to end the job in progress at the printer.

Indicator Lights

The control panel indicator lights are described in the following table.

Table 3-2. Indicator Lights

Indicator=	State	Explanation	Action
Ready	On	Ready to receive data.	No action required.
	Flashing	Going offline.	No action required.
	Off	Printer is offline.	Press Go to place printer online.
Data	On	Data is resident in the printer and processed as far as possible. More data is expected, but no activity on the channel at this time.	No action required.
	Flashing	Data is being received or processed.	No action required.
	Off	No data is being received or processed in the printer.	No action required.
Attention	On	Catastrophic error. Printer system is halted.	Turn printer off, then on. If problem persists, see Chapter 7.
	Flashing	The printer needs attention.	Read and respond to display panel message.
	Off	There are no messages or error conditions requiring attention.	No action required.

Settings and Defaults

The printer makes most printing decisions based on either temporary settings or factory (permanent) defaults.

Note

Settings you send from software applications override printer defaults.

Temporary Settings are the values set for the current print job by your software application. Temporary settings remain in effect until the current print job is finished.

Control Panel Defaults are the values entered by selecting a control panel item and pressing **SELECT**. An asterisk (*) next to the item name indicates that it is now the default. The printer retains default settings even when power is turned off.

Factory Defaults are the permanent default values for each menu item set at the factory. These values are listed in table 3-3 on page 56.

Printer Driver Information

You can override or change any Printing Menu setting through most software applications and from the printer driver. When you change a setting from the printer control panel, the new setting becomes the printer default value.

Paper Source Default

The printer paper source is specified by the print job, not the printer control panel. The following paragraphs apply when the current job does not specify a paper source. Unless changed or not specified by the current job, the software application, or the printer driver, the paper source default is determined by the “Cold Reset Paper Size” (letter or A4) set in the Service Mode Menu.

- If Tray 1 is set to cassette, it will look for the default size.
- If there is no paper in Tray 1, and Tray 4 is installed and loaded with the Cold Reset Paper Size, the printer will pull from Tray 4.
- The printer pulls paper from Tray 5 first if the Optional 2 x 500-sheet Input Tray is installed.
- If there is no paper in Tray 1, and Tray 4 is not installed, the printer will pull from the first tray containing the Cold Reset Paper Size.
- If none of the trays contain the Cold Reset Paper Size, the printer will prompt the user to put letter or A4 paper in Tray 1.

Resetting the Printer

Cold Reset

Cold Reset clears all data from the printer memory and sets all the defaults back to the factory settings.

CAUTION

Performing a Cold Reset resets the JetDirect configuration. To avoid making changes to your configuration, remove the JetDirect card before performing a Cold Reset.

If possible, print a Configuration Page prior to performing a Cold Reset. This will document current settings for later reference.

To perform a Cold Reset:

1. Turn off the printer.
2. While pressing **Go**, turn the printer on. `COLD RESET` appears briefly on the display, then `INITIALIZING` appears. After a few seconds, `RESTORING FACTORY SETTINGS` appears on the display, followed by `OFFLINE`. The Cold Reset is complete.
3. Press **Go** to return the printer online. `READY` appears on the display.

Setting the Display Language

1. Press and hold **SELECT** while powering on. Hold **SELECT** until `SELECT LANGUAGE` appears.
2. Release **SELECT**. `INITIALIZING` appears briefly. Wait for `LANGUAGE=ENGLISH` to appear.
3. Press **+** repeatedly until the desired language appears.
4. Press **SELECT** to save your choice. An asterisk (*) will appear beside your language selection.

Table 3-3. Factory Default Settings

DUPLEX=	OFF
APPEND CR TO LF	NO
AUTO CONTINUE=	ON
CLEARABLE WARNINGS	JOB
CONFIGURE CUSTOM PAPER	NO
COPIES	1
COURIER	REGULAR
ECONOMODE=	OFF
FORM	60 LINES
I/O TIMEOUT=	15 SECONDS
IO BUFFER=	AUTO
JAM RECOVERY=	AUTO
MANUAL FEED	OFF
ORIENTATION=	PORTRAIT
OVERRIDE A4/LETTER	NO
PAPER DEST=	STANDARD OUTPUT BIN
PAPER=	LETTER
PARALLEL ADV FUNCTIONS	ON
PARALLEL HIGH SPEED SETTING=	YES
PCL FONT NUMBER	0
PCL FONT PITCH	10
PCL FONT SOURCE	INTERNAL
PCL SYMBOL SET	PC-8
PERSONALITY=	AUTO
POWERSAVE ON=	1 HOUR
PRINT PS ERRORS	OFF
RET=	MEDIUM
RESOLUTION=	FASTRES 1200
RESOURCE SAVE=	OFF

Table 3-3. Factory Default Settings (continued)

TONER DENSITY=	3
TONER LOW=	CONTINUE
TRAY 1 MODE	FIRST
TRAY 2 TYPE	PLAIN
TRAY 3 TYPE	PLAIN
WIDE A4	NO

Control Panel Menus

Press **MENU** to cycle through the control panel menus. Each menu is described in a separate table in this section. Figure 3-3 (see page 83) provides a map of all the menus and their associated items. Menu items are displayed only if their associated option is installed, or their function is activated.

All menus and their associated items are accessible when the printer is online. In menu mode, if no keys are pressed for approximately 30 seconds, the system will automatically return to the top level and display either an existing error, or one of the following:

- **READY**, if the printer was online.
- **OFFLINE**, if the printer was offline.

To select a menu item

- 1 Press **MENU** repeatedly until the desired menu appears.
- 2 Press **ITEM** repeatedly until the desired item appears.
- 3 Press **+** repeatedly (or hold down **+** to scroll) until the desired setting appears.
- 4 Press **SELECT** to save the selection. An asterisk (*) appears next to the selection, indicating that it is now the default.
- 5 Press **MENU** or **GO** to exit the menus.

Note

Shaded items appear only if the associated option or function is activated.

Information Menu

This menu contains printer information pages that give details about the printer and its configuration. To print a page from the information menu, scroll to the desired page and press **SELECT**.

Table 3-4. Information Menu

Item	Explanation
PRINT MENU MAP	The menu map shows the layout and current settings of the control panel menu items.
PRINT CONFIGURATION	The configuration page shows the printer's current configuration. If an HP JetDirect print server card is installed (HP LaserJet 8000 N, 8000 DN, and HP Mopier 240 printers), a JetDirect configuration page will print out as well.
PRINT PCL FONT LIST	The PCL font list shows all the PCL fonts currently available to the printer.
PRINT PS FONT LIST	The PS font list shows all the PS fonts currently available to the printer.
PRINT FILE DIRECTORY	The file directory shows information for all of the installed mass storage devices.
PRINT EVENT LOG	The event log lists printer events or errors.
SHOW EVENT LOG	This item allows you to view the most recent printer events on the control panel display. Press - VALUE + to scroll through the event log entries.
PRINT PAPER PATH TEST	The paper path test can be used to verify that the paper path is working properly, or to troubleshoot problems with a type of paper. Choose the input tray, output bin, duplexer (if available), and number of copies.

Paper Handling Menu

When paper handling settings are correctly configured through the control panel, you can print by choosing the type and size of paper from the printer driver or software application.

Some items in this menu (such as duplex and manual feed) can be accessed from a software application, or from the printer driver (if the appropriate driver is installed). Printer driver and software application settings override control panel settings.

Table 3-5. Paper Handling Menu

Item	Values	Explanation
TRAY 1 MODE= FIRST	FIRST CASSETTE	Determine how the printer will use Tray 1. FIRST: If paper is loaded in Tray 1, the printer will pull paper from that tray first. CASSETTE: A paper size must be assigned to Tray 1 using the TRAY 1 SIZE option (the next item in this menu when TRAY 1 MODE=CASSETTE). This allows Tray 1 to be used as a reserved tray.
TRAY 1 SIZE= LETTER	For supported paper sizes, see page 4.	This item appears only when TRAY 1 MODE=CASSETTE. Set the value to correspond with the paper size currently loaded in Tray 1.
TRAY 1 TYPE= PLAIN	For supported paper types, see page 4.	This item appears only when TRAY 1 MODE=CASSETTE. Set the value to correspond with the paper type currently loaded in Tray 1.
TRAY 2 TYPE= PLAIN	For supported paper types, see page 4.	Set the value to correspond with the paper type currently loaded in Tray 2.
TRAY 3 TYPE= PLAIN	For supported paper types, see page 4.	Set the value to correspond with the paper type currently loaded in Tray 3.
TRAY 4 TYPE= PLAIN	For supported paper types, see page 4.	Set the value to correspond with the paper type currently loaded in the Optional 2000-sheet Input Tray (Tray 4) or Tray 4 of the Optional 2 x 500-sheet Input Tray (Trays 4 and 5).

Table 3-5. Paper Handling Menu (continued)

Item	Values	Explanation
TRAY 5 TYPE= PLAIN	For supported paper types, see page 4.	Set the value to correspond with the paper type currently loaded in Tray 5 of the Optional 2 x 500-sheet Input Tray (Trays 4 and 5).
PAPER DEST= STANDARD OUTBIN	STANDARD OUTBIN LEFT OUTBIN OPTIONAL BIN	This item appears only when a mailbox is installed. Set the value to correspond with the appropriate bin.
MANUAL FEED=OFF	OFF ON	Feed the paper manually from Tray 1, rather than automatically from a tray. When MANUAL FEED=ON and Tray 1 is empty, the printer goes offline when it receives a print job and displays MANUALLY FEED [PAPER SIZE].
DUPLEX=OFF	OFF ON	This item appears only when an optional duplexer is installed. Set the value to ON to print on both sides (duplex) or OFF to print on one side (simplex) of a sheet of paper.
OVERRIDE A4/LETTER=NO	NO YES	Choose YES to print on letter-size paper when an A4 job is sent, but no A4-size paper is loaded in the printer (or to print on A4-size paper when a letter job is sent, but no letter paper is loaded in the printer).

Print Quality Menu

Some items in this menu can be accessed from a software application, or from the printer driver (if the appropriate driver is installed). Printer driver and software application settings override control panel settings.

Table 3-6. Print Quality Menu

Item	Values	Explanation
RESOLUTION= FASTRES 1200	300 600 FASTRES 1200	Select the resolution from the following values: 300: Produces draft print quality at the printer's maximum speed (24 ppm). 300 dpi (dots per inch) is recommended for some bitmapped fonts and graphics, and for compatibility with the HP LaserJet III family of printers. 600: Produces high print quality at the printer's maximum speed (24 ppm). FASTRES 1200: Produces optimum print quality (comparable to 1200 dpi) at the printer's maximum speed (24 ppm). Note It is best to change the resolution from the printer driver or software application. (Driver and software settings override control panel settings.)
RET=MEDIUM	OFF LIGHT MEDIUM DARK	Use the printer's Resolution Enhancement technology (REt) setting to produce print with smooth angles, curves, and edges. All print resolutions, including FastRes 1200, benefit from REt. Note It is best to change the REt setting from the printer driver or software application. (Driver and software settings override control panel settings.)

Table 3-6. Print Quality Menu (continued)

Item	Values	Explanation
ECONOMODE=OFF	OFF ON	Turn EconoMode on (to save toner) or off (for high quality). EconoMode creates draft-quality printing by reducing the amount of toner on the printed page by up to 50%. CAUTION HP does not recommend full-time use of EconoMode. (If EconoMode is used full-time, it is possible that the toner supply will outlast the mechanical parts in the toner cartridge.) Note It is best to turn EconoMode on or off from the printer driver or software application. (Driver and software settings override control panel settings.)
TONER DENSITY=3	1 2 3 4 5	Lighten or darken the print on the page by changing the toner density setting. The settings range from 1 (light) to 5 (dark), but the default setting of 3 usually produces the best results. Use a lower toner density setting to save toner. Note It is best to change the toner density from the printer driver or software application. (Driver and software settings override control panel settings.)
CREATE CLEANING PAGE	No value to select.	Press SELECT to print a cleaning page (for cleaning excess toner from the paper path). In order for the cleaning page to work properly, print the page on copier grade paper (not bond or rough paper). Follow the instructions on the cleaning page.

Printing Menu

Some items in this menu can be accessed from a software application, or from the printer driver (if the appropriate driver is installed). Printer driver and software application settings override control panel settings.

Table 3-7. Printing Menu

Item	Values	Explanation
COPIES=1	1 to 999	<p>Set the default number of copies by selecting any number from 1 to 999. Press - VALUE + once to change the setting by increments of 1, or hold down - VALUE + to scroll by increments of 10.</p> <p>Note</p> <p>It is best to set the number of copies from the printer driver or software application. (Driver and software settings override control panel settings.)</p>
PAPER= LETTER	For supported paper types, see page 4.	<p>Set the default image size for paper and envelopes. (The item name will change from paper to envelope as you scroll through the available sizes.)</p> <p>Note</p> <p>The defaults indicated here are for 110V printers. The default paper size for 220V printers is A4. The default envelope size for 220V printers is DL.</p>
CONFIGURE CUSTOM PAPER=NO	NO YES	<p>NO: The custom paper menu items are not accessible. YES: The custom paper menu items appear (see below).</p>
FORM=60 LINES	5 to 128	<p>Sets vertical spacing from 5 to 128 lines for default paper size. Press - VALUE + once to change the setting by increments of 1, or hold down - VALUE + to scroll by increments of 10.</p>
ORIENTATION= PORTRAIT	PORTRAIT LANDSCAPE	<p>Determine the default orientation of print on the page.</p> <p>Note</p> <p>It is best to set the page orientation from the printer driver or software application. (Driver and software settings override control panel settings.)</p>

Table 3-7. Printing Menu (continued)

Item	Values	Explanation
PCL FONT SOURCE=INTERNAL	INTERNAL SOFT SLOT 1, 2, or 3	INTERNAL: Internal fonts. SOFT: Permanent soft fonts. SLOT 1, 2, or 3: Fonts stored in one of the three DIMM slots.
PCL FONT NUMBER= 0	0 to 999	The printer assigns a number to each font and lists them on the PCL Font List. The font number appears in the Font # column of the printout.
PCL FONT PITCH= 10.00	0.44 to 99.99	This item might not appear, depending on the font selected. Press - VALUE + once to change setting by increments of 0.01 for pitch, or hold down - VALUE + to scroll by increments of 1.
PCL SYMBOL SET=PC-8	PC-8 many others	Select any one of several available symbol sets from the printer's control panel. A symbol set is a unique grouping of all the characters in a font. PC-8 or PC-850 is recommended for line draw characters.
COURIER=REGULAR	REGULAR DARK	Select the version of Courier font to use: REGULAR: The internal Courier font available on the HP LaserJet 4 series printers. DARK: The internal Courier font available on the HP LaserJet III series printers. Both fonts are not available at the same time.
WIDE A4=NO	NO YES	The Wide A4 setting changes the number of characters that can be printed on a single line of A4 paper. NO: Up to 78 10-pitch characters can be printed on one line. YES: Up to 80 10-pitch characters can be printed on one line.
APPEND CR TO LF= NO NO	NO YES	Select YES to append a carriage return to each line feed encountered in backward-compatible PCL jobs (pure text, no job control). Some environments, such as UNIX, indicate a new line using only the line feed control code. This option allows the user to append the required carriage return to each line feed.

Table 3-7. Printing Menu (continued)

Item	Values	Explanation
PRINT PS ERRORS=OFF	OFF ON	Select ON to print the PS error page when PS errors occur.

Configuration Menu

Items in this menu affect the printer's behavior. Configure the printer according to your printing needs.

Table 3-8. Configuration Menu

Item	Values	Explanation
POWERSAVE ON= 1 HOUR	OFF 15 MINUTES 30 MINUTES 1 HOUR 2 HOURS 3 HOURS	<p>Set the printer to enter PowerSave after it has been idle for a specified amount of time. Turning PowerSave off is not recommended. The PowerSave feature does the following:</p> <ul style="list-style-type: none">Minimizes the amount of power consumed by the printer when it is idle.Reduces wear on the printer's electronic components. (Turns off the display's backlight.) <p>When you send a print job, press a control panel key, open a paper tray, or open the top cover, the printer automatically comes out of PowerSave mode.</p> <p>Note</p> <p>PowerSave turns off the backlight on the display, but the display is still readable.</p>
PERSONALITY= AUTO	AUTO PCL PS	<p>Select the default printer language (personality). Normally you should not change the printer language (the default is AUTO). If you change it to a specific printer language, the printer will not automatically switch from one language to another unless specific software commands are sent to the printer.</p>

Table 3-8. Configuration Menu (continued)

Item	Values	Explanation
RESOURCE SAVE= OFF	OFF ON AUTO	<p>This item dedicates printer memory to save each language's permanent resources. (You might need to add memory to the printer in order for this item to appear.) The amount of memory set aside can be different for each installed language. Some languages might have memory set aside for resource saving without requiring all languages to do so. Any time the amount of memory dedicated to a specific language is changed, all languages will lose all saved resources, including any unprocessed print jobs.</p> <p>OFF: No language resource saving is performed, and language-dependent resources, such as fonts and macros, are lost when language or resolution changes.</p> <p>ON: An item will appear for each installed language that allows the user to allocate a particular amount of memory to that language's resource saving area. (See the items below.)</p> <p>AUTO: The printer automatically determines the amount of memory to use for each installed language's resource saving area.</p>
CLEARABLE WARNINGS=JOB	JOB ON	<p>Set the amount of time that a clearable warning is displayed on the printer's control panel.</p> <p>JOB: Warning messages display on the control panel until the end of the job from which they were generated.</p> <p>ON: Warning messages display on the control panel until Go is pressed.</p>
AUTO CONTINUE= ON	ON OFF	<p>This item determines how the printer reacts to errors.</p> <p>ON: If an error occurs that prevents printing, the message will display, and the printer will go offline for 10 seconds before returning online.</p> <p>OFF: If an error occurs that prevents printing, the message will remain on the display and the printer will remain offline until Go is pressed.</p>

Table 3-8. Configuration Menu (continued)

Item	Values	Explanation
TONER LOW=CONTINUE	CONTINUE STOP	This item determines how the printer behaves when toner is low. The TONER LOW message will first appear when the toner cartridge is almost out of toner. (About 100 to 300 sheets can still be printed.) CONTINUE: The printer will continue to print while the TONER LOW message is displayed. STOP: The printer will go offline and wait for further action.
JAM RECOVERY= AUTO	AUTO ON OFF	This item determines how the printer behaves when a paper jam occurs. AUTO: The printer automatically selects the best mode for printer jam recovery (usually ON). This is the default setting. ON: The printer automatically reprints pages after a paper jam is cleared. OFF: The printer does not reprint pages following a paper jam. Printing performance might be increased with this setting.

I/O Menu

Items in the I/O (input/output) Menu affect the communication between the printer and the computer.

Table 3-9. I/O Menu

Item	Values	Explanation
I/O TIMEOUT=15	5 to 300	Select the I/O time-out period in seconds. (I/O time-out refers to the time, measured in seconds, that the printer waits before ending a print job.) This setting allows you to adjust time-out for best performance. If data from other ports appear in the middle of your print job, increase the time-out value. Press - VALUE + once to change settings by increments of 1, or hold down - VALUE + to scroll by increments of 10.
I/O BUFFER=	AUTO ON OFF	Allocate memory for I/O buffering. AUTO: The printer automatically reserves memory for I/O buffering. Additional configurations are not required and the I/O BUFFER SIZE menu item does not appear. ON: The I/O BUFFER SIZE item appears (see below). Specify the amount of memory to be used for I/O buffering. OFF: I/O buffering is not performed and the I/O BUFFER SIZE item does not appear. When the I/O buffer setting is changed, any downloaded resources (such as fonts or macros) will need to be downloaded again, unless they are stored on an optional hard disk or flash DIMM.
PARALLEL SPEED=	HIGH YES NO	Select the speed at which data is transmitted to the printer. YES: The printer accepts faster parallel communications used for connections with newer computers. NO: The printer accepts slower parallel communications used for connections with older computers.

Table 3-9. I/O Menu (continued)

Item	Values	Explanation
PARALLEL ADV FUNCTIONS=ON	ON OFF	Turn the bidirectional parallel communication on or off. The default is set for a bidirectional parallel port (IEEE-1284). This setting allows the printer to send status messages to the computer. (Turning the parallel advanced functions on might slow language switching.)

EIO Menu

EIO (enhanced input/output) Menus depend on the particular accessory product installed in an EIO slot of the printer. If the printer contains an HP JetDirect print server EIO card, you can configure basic networking parameters using the EIO Menu. These and other parameters can also be configured through HP JetAdmin.

Table 3-10. EIO Menu

Item	Values	Explanation
CFG NETWORK=NO	NO YES	NO: The JetDirect Menu is not accessible. YES: The JetDirect Menu appears.
NOVELL=ON	ON OFF	Select whether the IPX/SPX protocol stack (in Novell NetWare networks, for example) is enabled (on) or disabled (off).
DLC/LLC=ON	ON OFF	Select whether the DLC/LLC protocol stack is enabled (on) or disabled (off).
TCP/IP=ON	ON OFF	Select whether the TCP/IP protocol stack is enabled (on) or disabled (off).
ETALK=ON	ON OFF	Select whether the Apple EtherTalk protocol stack is enabled (on) or disabled (off).
CFG NOVELL=NO	NO YES	NO: The IPX/SPX Menu is not accessible. YES: The IPX/SPX Menu appears. In the IPX/SPX Menu, you can specify the frame type parameter used on your network. The default is AUTO, to automatically set and limit the frame type to the one detected. For Ethernet cards, frame type selections include EN_8023, EN_LII, EN_8022, EN_SNAP. For Token Ring cards, frame type selections include TR_8022, TR_SNAP. In the IPX/SPX Menu for Token Ring cards, you can also specify NetWare Source Routing parameters, which include SRC_RT=AUTO (default), OFF, SINGLE R, or ALL RT.

Table 3-10. EIO Menu (continued)

Item	Values	Explanation
CFG TCP/IP=NO	NO YES	NO: The TCP/IP Menu is not accessible. YES: The TCP/IP Menu appears. In the TCP/IP Menu, you can specify BOOTP=YES for TCP/IP parameters to be automatically loaded from a bootp or DHCP server when the printer is turned on. If you specify BOOTP=NO, you can manually set selected TCP/IP parameters from the control panel. You can manually set each byte of the IP address (IP), Subnet Mask (SM), Syslog Server (LG), and Default Gateway (GW). Also, you can manually set the Timeout time period.
CFG ETALK=NO	NO YES	NO: The EtherTalk Menu is not accessible. YES: The EtherTalk Menu appears. In the EtherTalk Menu you can set the AppleTalk phase parameter (ETALK PHASE=1 or 2) for your network.

Resets Menu

CAUTION

Use this menu with caution. You can lose buffered page data or printer configuration settings when you select these items. Only reset the printer under the following circumstances:

- You want to restore the printer's default settings.
- Communication between the printer and computer has been interrupted.
- You are having problems with a port.

The items in the Resets Menu will clear all memory in the printer, while **CANCEL JOB** clears only the current job.

Table 3-11. Resets Menu

Item	Explanation
RESET MEMORY	This item clears the printer buffer and the active I/O input buffer, and makes the control panel defaults current. Resetting memory during a print job can result in data loss.
RESTORE FACTORY SETTINGS	This item performs a simple reset and restores most of the factory (default) settings. This item also clears the input buffer for the active I/O. Resetting memory during a print job can result in data loss.
RESET ACTIVE I/O CHANNEL	This item performs a simple reset and clears the input and output buffers (for the active I/Os only). Resetting memory during a print job can result in data loss.
RESET ALL I/O CHANNELS	This item performs a simple reset and clears the input and output buffers for all I/Os.

Service Mode

The Service Mode should be used only by authorized service personnel. While in Service Mode, you can:

- Verify and set the Page Count and serial number. These are displayed on the Configuration Page.
- Set the Cold Reset Paper Size Default. (This sets the factory default paper size to either Letter or A4.)
- Clear the Event Log.

Initiate the Service Mode as follows:

- 1 Hold down **SELECT** and **JOB CANCEL** while powering on the printer, until all lights are illuminated and the Display is blank. (If the Display Panel reads `INTERNAL TEST` at this point, the keys were released too soon. Repeat this step until successful.)
- 2 Press **MENU**, then **SELECT**. The message `SERVICE MODE` is displayed briefly, then the printer automatically begins an `INTERNAL TEST`. After several seconds, both Control Panel Indicators turn off. (The printer may display `WARMING UP` if it has not warmed up completely.) After the printer has warmed up and passed the self test, `SERVICE MODE` is displayed.
- 3 Press **MENU** once to display `SERVICE MENU`.

To exit the Service Mode press **Go**.

Table 3-12. Service Mode Menu Items

Service Mode Menu Items	Item Choices	Actions Required
PAGECOUNT=	nnnnnnn	<p>Displays total number of pages printed by the printer.</p> <p>Press + to step through values above cursor. Press SELECT to activate choice. Cursor will move to next digit.</p> <p>Printer will set new number into NVRAM after least significant digit is selected. Pressing MENU or ITEM before completing all digits will cancel the new setting.</p> <p>Pressing MENU returns printer to the main menu system. Pressing ITEM moves to the next menu item.</p>
MAINTCOUNT=	nnnnnnn	<p>Displays the page count when the next preventative maintenance should be performed (maintenance should be performed every 350,000 pages).</p> <p>Press + to step through values above cursor. Press SELECT to activate choice. Cursor will move to next digit.</p> <p>Printer will set new number into NVRAM after least significant digit is selected. Pressing MENU or ITEM before completing all digits will cancel the new setting.</p> <p>Pressing MENU returns printer to the main menu system. Pressing ITEM moves to the next menu item.</p>
MAINTENANCE INTERVAL=	xxxxxxx	<p>Allows a service technician to change the page count when the PERFORM PRINTER MAINTENANCE message displays.</p> <p>This is provided for customers with printing environments that require more frequent maintenance cycles.</p>
SERIAL NUMBER=	xxxxxxxxxxx	<p>Displays printer serial number (also located on the printer back cover).</p> <p>Press + to step through values above cursor. Press SELECT to activate choice. Cursor will move to next digit.</p> <p>Printer will set new number into NVRAM after least significant digit is selected. Pressing MENU or ITEM before completing all digits will cancel the new setting.</p> <p>Pressing MENU returns printer to the main menu system. Pressing ITEM moves to the next menu item.</p>
COLD RESET PAPER=	LETTER * A4	<p>Press + to change setting. Press SELECT to activate choice.</p>

Table 3-12. Service Mode Menu Items (continued)

Service Mode Menu Items	Item Choices	Actions Required
DIAGNOSTICS=	OFF * ON	For factory test purposes ONLY. DO NOT change.
	PAGECOUNT=nnnnn nn	Press + to step through values above cursor. Press SELECT to activate choice. Cursor will move to next digit. Printer will set new number into NVRAM after least significant digit is selected. Pressing MENU or ITEM before completing all digits will cancel the new setting. Pressing MENU returns printer to the main menu system. Pressing ITEM moves to the next menu item.
CLEAR EVENT LOG		Press SELECT to activate. Printer returns to READY when completed.

Setting Page Count, Maintenance Count, and Serial Number

The page count, maintenance count, and printer serial numbers are stored in Non-Volatile Memory. `PAGECOUNT` is the total number of images printed by the printer, `MAINTCOUNT` is the page count when the next preventative maintenance should be performed (every 350,000 images), and `SERIAL NUMBER=` is the printer serial number (also located on the printer back cover).

If it is necessary to replace the Formatter PCA, these numbers should be set to the current values to accurately reflect the age of the print engine. The procedures for setting these values are listed in table 3-12.

Before removing the old Formatter PCA, print a Configuration Page to verify the current values, if possible.

Note

If it is not possible to print a Configuration Page, try to verify the values before replacing the Formatter PCA by following steps 1 through 3, below.

After verifying the page count, maintenance count, and printer serial number from the old Formatter PCA, replace it with the new PCA.

- 1 Enter the Service Mode as previously described in this chapter.
- 2 When `SERVICE MODE` is displayed, press **MENU** to access the Service Menu.
- 3 Press **ITEM** to display `PAGECOUNT=`, `MAINTCOUNT=`, and `SERIAL NUMBER=`.
- 4 Enter the appropriate values for each item.
- 5 Press **Go** to exit Service Mode.

Setting the Cold Reset Default Paper Size

When replacing a Formatter PCA with a default paper size setting of A4, set `COLD RESET PAPER=` to A4.

- 1 Enter the Service Mode as previously described in this chapter.
- 2 Press **MENU** to access the Service Menu.
- 3 Press **ITEM** to step through the menu until `COLD RESET PAPER=LETTER*` is displayed.
- 4 Press **+** to toggle between Letter and A4 paper.
- 5 Press **SELECT** to activate your choice.
- 6 Press **GO** to exit Service Mode.
- 7 Perform a Cold Reset to activate new choice.

Testing the Printer

Paper Path Test

You can test printer operation with the Paper Path Test in the Test Menu. It will print 1, 10, 100, or 500 (single or 2-sided) pages from any of the paper trays (or the Envelope Feeder) and deliver them to a previously specified output bin.

First, select `PAPER DESTINATION` and `2-SIDED` printing (if a duplexer is installed) in the Configuration Menu (table 3-8) and then run the Paper Path Test from the Information Menu (table 3-4).

Configuration Page

When you print a Configuration Page, the printer checks its internal controller and I/O interface, then prints a page showing the overall printer configuration (see figure 3-2 on page 81), and a Menu Map showing the current menu settings (see figure 3-3 on page 83). You can review these printouts to verify proper installation of installed accessories, options, and personalities.

- 1 Press `MENU` until `INFORMATION MENU` appears.
- 2 Press `ITEM` until `PRINT CONFIGURATION` appears.
- 3 Press `SELECT` to print the configuration pages.

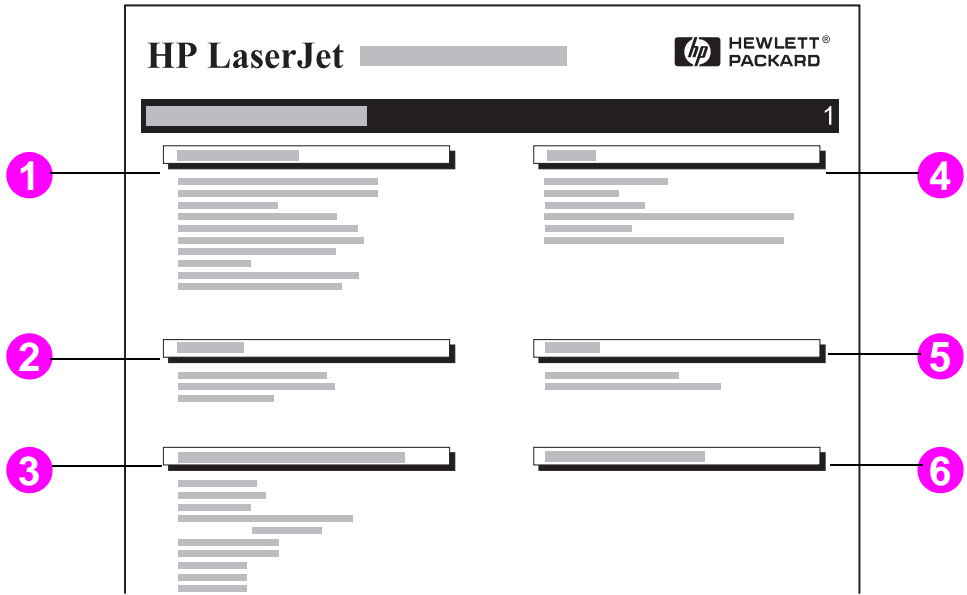

Figure 3-2 Configuration Page

Table 3-13. Key to Figure 3-2

- 1 **Printer Information** lists the serial number, HP JetSend IP addresses, page counts, and other information for the printer.
 - 2 **Event Log** lists the number of entries in the log, the maximum number of entries viewable, and the last three entries.
 - 3 **Installed Personalities and Options** lists all printer languages that are installed (such as PCL and PS) and lists options that are installed in each DIMM slot and EIO slot.
 - 4 **Memory** lists the printer memory, PCL Driver Work Space (DWS), and I/O buffering and resource saving information.
 - 5 **Security** lists the status of the printer's control panel lock, control panel password, and disk drive.
 - 6 **Paper Tray and Options** lists the size settings for all trays and lists any optional paper handling accessories installed.
-

Menu Map

1

INFORMATION MENU

PRINT
MENU MAP
PRINT
CONFIGURATION
PRINT
PCL FONT LIST
PRINT
PS FONT LIST
PRINT
EVENT LOG
SHOW
EVENT LOG
PRINT
PAPER PATH TEST

PAPER HANDLING MENU

TRAY 1 MODE=FIRST
TRAY 2 TYPE=PLAIN
TRAY 3 TYPE=PLAIN
PAPER DEST=STANDARD OUTBIN
MANUAL FEED=OFF
OVERRIDE AA/LETTER=NO
CONFIGURE FUSER MODE MENU=NO

PRINT QUALITY MENU

RESOLUTION=FASTRES 1200
RET=MEDIUM
ECONOMODE=OFF
TONER DENSITY=3
CREATE
CLEANING PAGE

PRINTING MENU

COPIES=1
PAPER=LETTER
CONFIGURE CUSTOM PAPER=NO
FORM=60 LINES
ORIENTATION=PORTRAIT
PCL FONT SOURCE=INTERNAL
PCL FONT NUMBER=0
PCL FONT PITCH=10.00
PCL SYMBOL SET=PC-8
COURIER=REGULAR
WIDE AA=NO

Menu Continued

APPEND CR TO LF=NO
PRINT PS ERRORS=OFF

CONFIGURATION MENU

POKERSAVE=30 MINUTES
PERSONALITY=AUTO
RESOURCE SAVE=OFF
CLEARABLE WARNINGS=JOB
AUTO CONTINUE=ON
TONER LOW=CONTINUE
RAM DISK=OFF
JAM RECOVERY=AUTO
SMALL PAPER SPEED=NORMAL

I/O MENU

E/O TIMEOUT=15
I/O BUFFER=AUTO
PARALLEL HIGH SPEED=YES
PARALLEL ADV FUNCTIONS=ON
SERIAL PACING=DTR/DSR
SERIAL BAUD RATE=9600
SERIAL DTR POLARITY=HIGH

EIO 3 JETDIRECT MENU

CFG NETWORK=NO

RESETS MENU

RESET MEMORY
RESTORE FACTORY SETTINGS
RESET ACTIVE I/O CHANNEL
RESET ALL I/O CHANNELS

Figure 3-3 Menu Map Page

Table 3-14. Key to Figure 3-3

Information Menu lets you print information pages and perform a paper path test.

Paper Handling Menu contains paper handling options.

Print Quality Menu lets you set print quality settings.

Printing Menu contains various print options.

Configuration Menu contains various printer settings.

I/O Menu contains communication settings.

Resets Menu shows options for resetting the printer.

Cold Reset

Cold Reset clears all data from the printer memory and sets all the defaults (except Service Mode settings) back to the factory settings.

CAUTION

Performing a Cold Reset resets the JetDirect configuration. To avoid making changes to your configuration remove the JetDirect card before performing a Cold Reset.

If possible print a Configuration Page prior to performing a Cold Reset. This will document current settings for later reference.

To perform a Cold Reset:

- 1 Turn the printer off.
- 2 While holding the **Go** key down, turn the printer on. `INITIALIZING`, and then `RESTORING FACTORY SETTINGS` appears briefly on the display. The display will read `OFFLINE`. Press **Go** to bring the printer online. The Cold Reset is now complete.

4 Maintenance and Adjustments

Chapter Contents

Cleaning the Printer and Accessories- - - - -	88
Preventative Maintenance - - - - -	91
Tray Adjustment Procedure- - - - -	92
Tray 4 (2000-sheet Input Tray) Adjustment Procedure - - -	94

Cleaning the Printer and Accessories

To maintain print quality and paper performance, thoroughly clean the printer and the paper handling accessories:

- Every time you change the toner cartridge.
- After printing approximately 15,000 images.
- Whenever print quality problems occur.

Clean the outside surfaces with a lightly dampened cloth. Clean the inside with only a dry, lint-free cloth. Use the guidelines listed in table 4-1. Observe the warnings and cautions below.

WARNING!

Before you begin these steps, turn the printer off and unplug all power cords to avoid shock hazard.

Be careful when cleaning around the Fusing Assembly area. It may be HOT.

CAUTION

To avoid permanent damage to the toner cartridge, do not use ammonia-based cleaners on or around the printer.

Do not touch the transfer roller with your fingers. This can cause print quality problems.

Cleaning the Printer

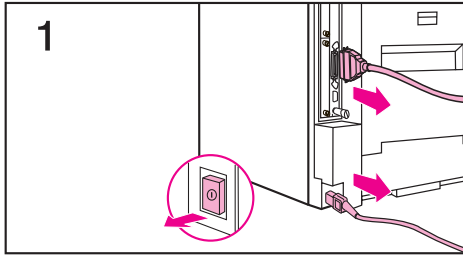

- 1 Before you begin these steps, turn the printer off and unplug all cords.
- 2 Open the top cover of the printer and remove the toner cartridge.

WARNING!

Avoid touching the adjacent fusing area. It may be HOT.

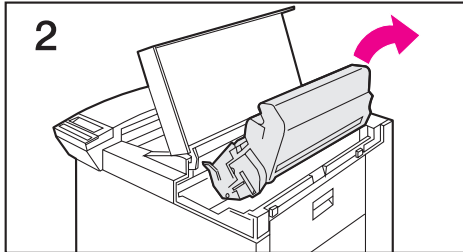

CAUTION

Do not touch the transfer roller (A). Oils from your hands can contaminate the roller and reduce print quality. If toner gets on your clothes, wipe it off with a dry cloth and wash your clothes in *cold* water. Hot water sets toner into fabric.

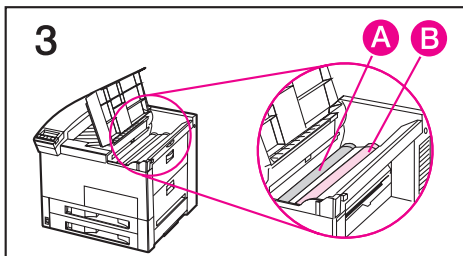

- 3 With a *dry* lint-free cloth, wipe any residue from the paper path area, the registration roller (B), and the toner cartridge cavity. Use the brush supplied with the printer to remove residue from tight areas.
- 4 Replace the toner cartridge, close the printer, reconnect all cables, and turn the printer on.

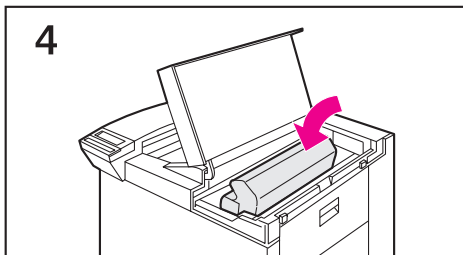

Table 4-1. Cleaning the Printer

Component	Cleaning Method/Notes
Outside Covers	Use a water-dampened cloth. Do not use solvents or ammonia-based cleaners.
Inside General	Use a dry, lint free cloth. Remove all dust, spilled toner, and paper particles.
Paper Pickup, Feed, and Retard Rollers	Use a water-dampened lint-free cloth.
Separation Pad	Use a dry lint-free cloth.
Registration Roller	Use a dry lint-free cloth.
Transfer Roller	Use a dry, lint-free cloth. DO NOT TOUCH the transfer roller with your fingers.
Fusing Assembly	Use a water-dampened lint-free cloth.

Cleaning Spilled Toner

Defective toner cartridges can develop leaks. Also, after a paper jam has occurred, there may be some toner remaining on the rollers and guides inside the printer. The pages that print immediately after the jam may pick up this toner.

Clean spilled toner with a cloth slightly dampened in cold water. Do not touch the Transfer Roller with the damp cloth or with your fingers. Do not use a vacuum cleaner unless it is equipped with a micro-fine particle filter.

Note

If toner gets on your clothing, use cold water to remove it. Hot water sets toner stains into fabric.

Preventative Maintenance

The user-conducted preventative maintenance cycle for this printer is every 350,000 images. The part numbers for the preventative maintenance kits are C3971B for the 100V printers, and C3972B for the 220V printers. The kits contain the following replacement parts: one Fusing Assembly, one Transfer Roller Assembly, and eight Feed/Separation Rollers [two each for Trays 2, 3, the 2000-sheet Input Tray (Tray 4), and the 2 x 500-sheet Input Tray (Trays 4 and 5)]. See Chapter 6 of this manual, and the instructions included in the kits for detailed replacement procedures.

The control panel message, `PERFORM PRINTER MAINTENANCE`, indicates that the 350,000 image maintenance is due. Upon completion of the maintenance procedures, go to the control panel Configuration Menu and set the `SERVICE MESSAGE=` to OFF.

Tray Adjustment Procedure

This procedure applies to Trays 2 and 3 (the standard paper trays in the printer) and Trays 4 and 5 in the 2 x 500-sheet Input Tray. To adjust the 2000-sheet Input Tray (Tray 4) see page 94.

The paper trays are mechanically aligned to the printer chassis at the factory. Perform this procedure **ONLY** if a paper tray has been replaced with a tray other than the original factory installed tray, or if the top margin of the image area is off-center more than 0.5 mm (0.02 inch). The adjustment procedure is identical for Trays 2 and 3.

Note

Before performing this procedure, check that the margins in your software application are properly set.

- 1 Load the paper tray being tested with letter or A4 size paper.
- 2 Perform a 1-sheet Paper Path Test from that tray (see Paper Path Test under Test Menu in Chapter 3).
- 3 See figure 4-1 and compare distance A to distance B.

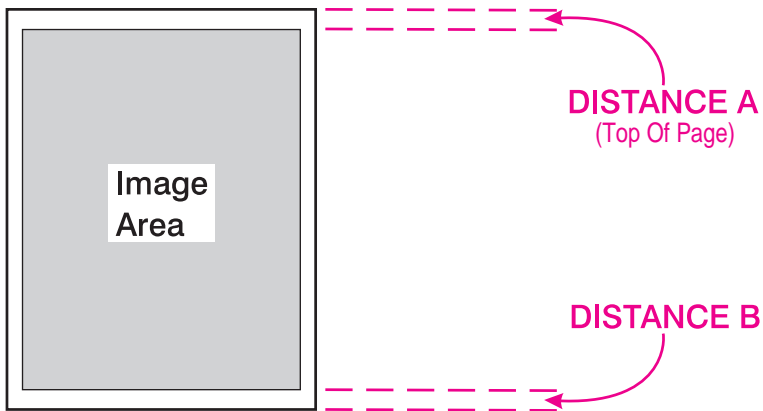

Figure 4-1 Image Area Margins

Note

See figure 4-2. Each adjustment notch changes the physical position of the tray by 0.5 mm (0.02 inch). Moving the lever counter-clockwise moves the tray inward and increases distance A. Moving the lever clockwise moves the tray outward and decreases distance A.

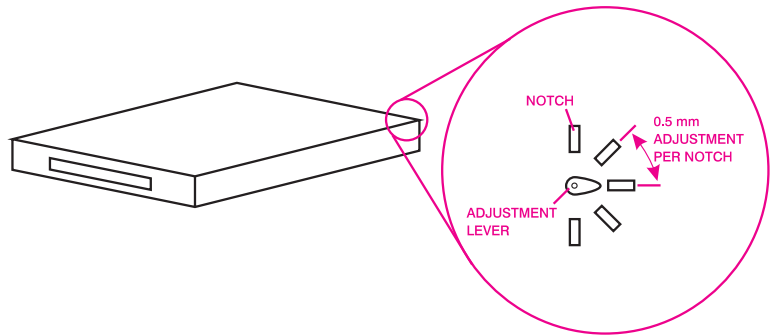

Figure 4-2 Tray Position Adjustment

- 1 If distance A is greater than distance B by more than 0.5 mm (0.02 inch), move the adjustment lever clockwise one notch.
- 2 If distance A is less than distance B by more than 0.5 mm (0.02 inch), move the adjustment lever counter-clockwise one notch.
- 3 After adjusting:
 - Reinstall the tray.
 - Re-run the Paper Path Test.
 - Recheck the measurements.
 - Re-adjust as necessary.

Tray 4 (2000-sheet Input Tray) Adjustment Procedure

This procedure applies to the 2000-sheet Input Tray (Tray 4). To adjust Trays 2 and 3 (the standard paper trays in the printer) and the 2 x 500-sheet Input Tray (Trays 4 and 5) see page 92.

In some cases, the registration from the 2000-sheet Input Tray causes print to start too close to the edge of the paper. This situation is not a typical occurrence. In most cases the 2000-sheet Input Tray offset is fine. Although this may or may not be within specification, it is unacceptable to some users. Perform the following adjustment procedure to correct the situation.

- 1 With the 2000-sheet Input Tray stand-alone, remove left, right and rear covers from the tray.
- 2 Remove the vertical transfer unit.
- 3 Open the 2000-sheet Input Tray paper tray.
- 4 Loosen both screws that support the paper tray locking bracket on the right side of the 2000-sheet Input Tray (see figure 4-3).

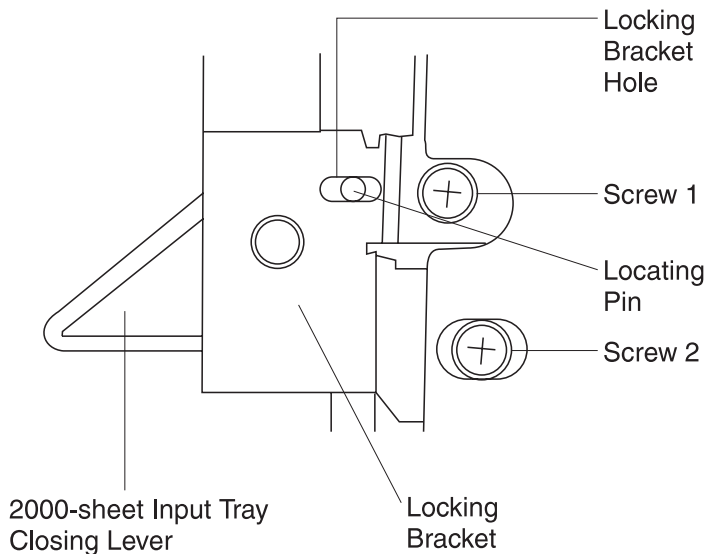

Figure 4-3 Tray 4 Position Adjustment

- 5 Locate the bracket hole and pin at the middle (right side) (see figure 4-3).
- 6 Slide the bracket so that the locating pin is positioned at the middle of the bracket hole.
- 7 Tighten both screws.
- 8 Loosen both screws that support the paper tray locking bracket on the left side of the 2000-sheet Input Tray.
- 9 Locate the bracket hole and pin at the middle (left side). Slide the bracket so the locating pin is positioned at the middle of the bracket hole.
- 10 Tighten both screws.
- 11 Reassemble the vertical transfer unit.
- 12 Make sure all the cables (vertical transfer unit and paper deck drive assembly) are reconnected.
- 13 Reinstall left, right, and rear covers to the tray.

Note

The locating pin position at the middle could still be unacceptable for some customers' applications. If so, repeat the procedure by moving the locating pin further back and testing the margin obtained.

5 Functional Overview

Chapter contents

Printer Functional Block Diagram - - - - -	-98
Power Distribution System - - - - -	-99
Formatter System - - - - -	102
DC Controller System - - - - -	105
Image Formation System- - - - -	107
Printer Input Sources- - - - -	136
Paper Jam Detection- - - - -	138
Printer Timing - - - - -	138

Printer Functional Block Diagram

Figure 5-1 is a functional block diagram of the printer showing the basic paths for signal, control, and media.

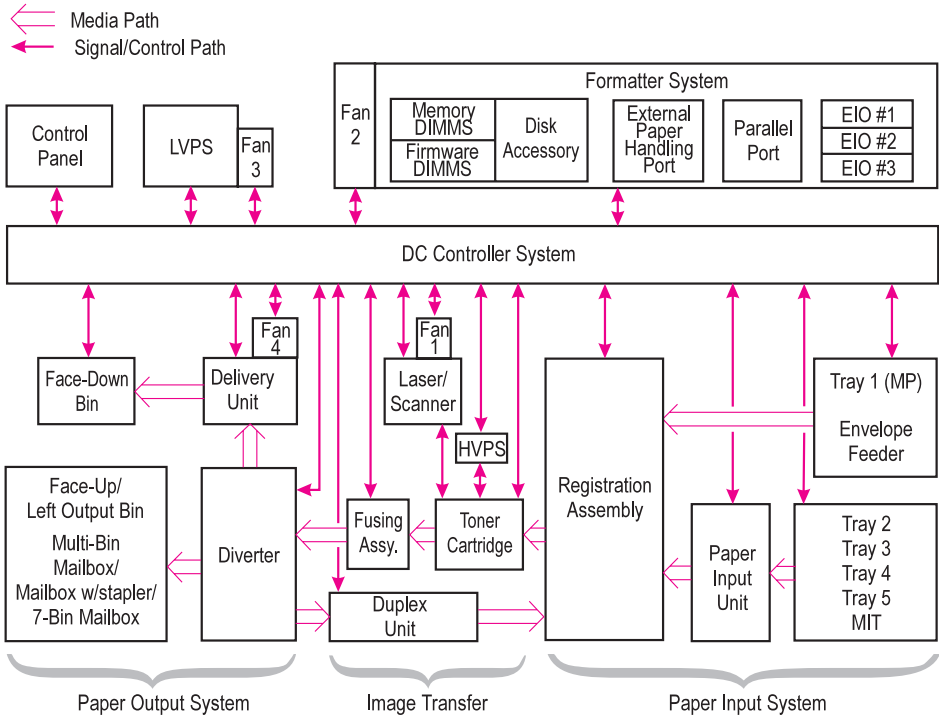

Figure 5-1 Printer Functional Block Diagram

Power Distribution System

The AC and DC power supply circuits are contained in the Low Voltage Power Supply (LVPS). The high voltages required for image formation are generated by the High Voltage Power Supply (HVPS). The LVPS and Distribution System is illustrated in figure 5-2. See the Reference Diagrams at the end of Chapter 7 for more details.

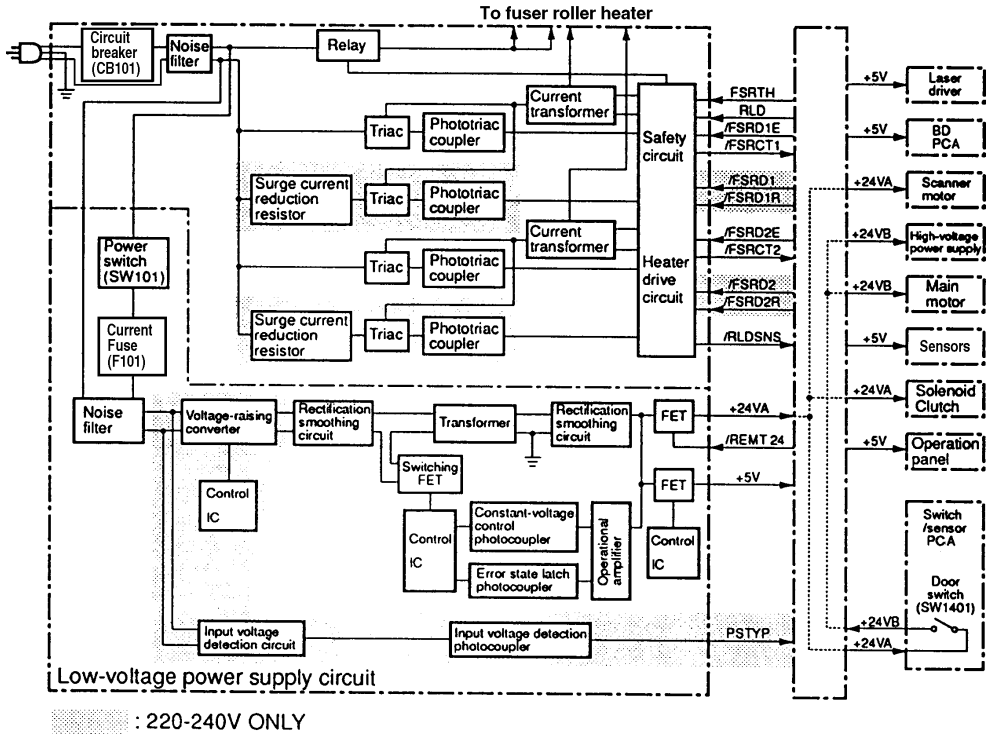

Figure 5-2 Low Voltage Power Distribution System

AC Power Distribution

The AC power circuitry supplies AC voltage whenever the power cord is connected, and the power switch is on. A toner cartridge must be installed and the top access door must be closed before AC voltage is supplied to the DC power circuits or the Fusing Assembly.

Overcurrent/Overvoltage Protection

There are two overcurrent/overvoltage devices in this printer:

- The resettable circuit breaker (CB101) shuts off AC input power to the LVPS in case of an AC overcurrent condition. To reset, remove the LVPS and press in the circuit breaker button (figure 5-3, callout 1).
- Fuse 101 interrupts AC input power to the +24V DC and +5V DC power circuits. To check or replace the fuse (figure 5-3, callout 2) you must remove the LVPS.

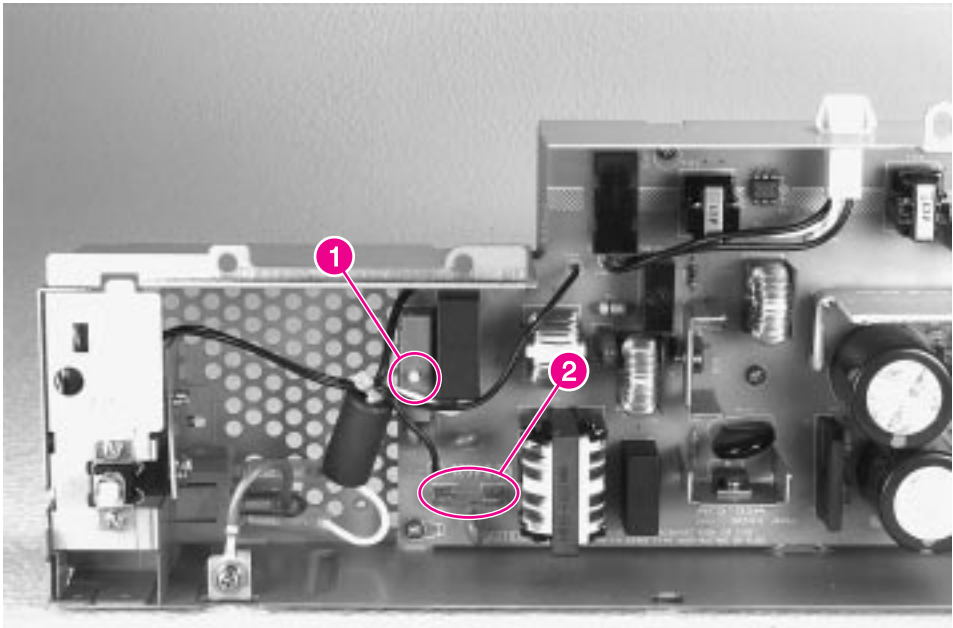

Figure 5-3 Low Voltage Power Supply

High Voltage Power Distribution

The High Voltage Power Supply (HVPS, see figure 5-4) applies a DC-biased AC voltage to the primary charging roller and the developing roller, and a programmed DC voltage (depending upon the phase of the printing process) to the Transfer Roller. See the General Timing Diagram (figure 5-23 on page 140) for HVPS timing information.

Toner Cartridge Detection

A toner level detector inside the toner cartridge is connected to the HVPS when the toner cartridge is installed. If the toner level drops below a predefined level, the `TONER LOW` message will appear on the display panel. If the toner cartridge is missing, `INSTALL TONER CARTRIDGE` will be displayed.

Print Density Adjustment

The HVPS also controls the image density by varying the voltages applied to the developing cylinder in the toner cartridge. These voltages determine the amount of toner applied to the photosensitive drum. Print density is adjusted from the control panel (Print Quality Menu) or from the driver software.

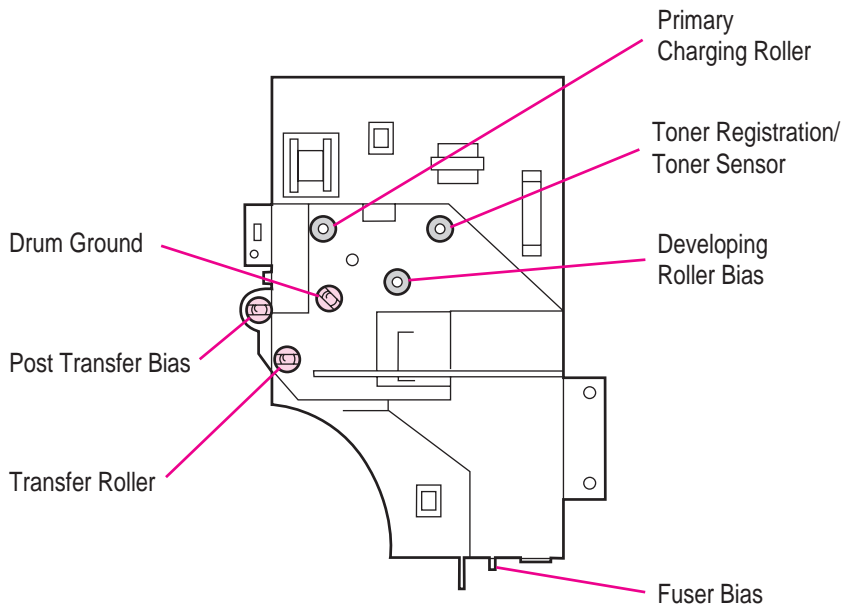

Figure 5-4 High Voltage Power Supply Contacts

Formatter System

The Formatter PCA is responsible for the following:

- Controlling the PowerSave mode.
- Receiving and processing print data from the various printer interfaces.
- Monitoring Control Panel inputs and relaying printer status information (through the Control Panel and the Bi-Directional I/O).
- Developing and coordinating data placement and timing with the print engine.
- Storing font information.
- Communicating with the host computer through the Bi-Directional Interface.

The Formatter PCA receives a print job from the bidirectional parallel port (IEEE 1284) and separates it into image information and instructions which control the printing process. The DC Controller synchronizes the Image Formation System with the Paper Input and Output Systems, and then signals the Formatter to send the print image data. The Formatter sends the print image data (dots) in the form of a VIDEO signal to start the printing process.

The Formatter PCA also provides the electrical interface and mounting locations for three EIO cards, additional memory DIMMs, the Disk Accessory, the Multibin Mailbox/5-bin Mailbox with Stapler, the 7-bin Tabletop Mailbox, and the 2 x 500-sheet Input Tray (Trays 4 and 5).

PowerSave

This user-adjustable feature (Configuration Menu) conserves power by shutting down the fuser and exhaust fans after the printer has been idle for 15 minutes; 30 minutes; 1, 2, or 3 hours. The printer retains all printer settings, downloaded fonts, and macros while in PowerSave mode. The default setting is PowerSave on, with a 1-hour idle time. (PowerSave can also be turned off from the control panel.)

The printer exits PowerSave mode and enters the warm up cycle when any of the following occurs:

- A print job, valid data, or a PML or PJL command is received at the parallel port or an EIO card.
- A Control Panel key is pressed.
- Any printer door (except the front access door) is opened and then closed.

- A paper tray is opened and then closed.
- The Engine Test microswitch is pressed.

Note

Printer error messages override the PowerSave message. The printer will enter PowerSave mode at the appropriate time, but the error message will continue to be displayed.

Resolution Enhancement (REt)

The Formatter PCA contains circuitry for Resolution Enhancement technology (REt), which modifies the standard video dot data on its way to the DC Controller to produce “smoothed” black-to-white boundaries. REt is user-controllable (on or off) from the control panel, or from some software applications. The default setting is on.

Note

REt settings sent from software applications or printer drivers override the control panel settings.

EconoMode

The EconoMode setting uses approximately 75% less toner than the normal printing mode by reducing the dot density. However, EconoMode does not extend toner cartridge component life. EconoMode, which can also be thought of as “draft mode,” is user selectable via the control panel (Print Quality Menu) and some software applications. The default setting is off.

Note

EconoMode does not affect print speed, memory usage, or extend toner cartridge life.

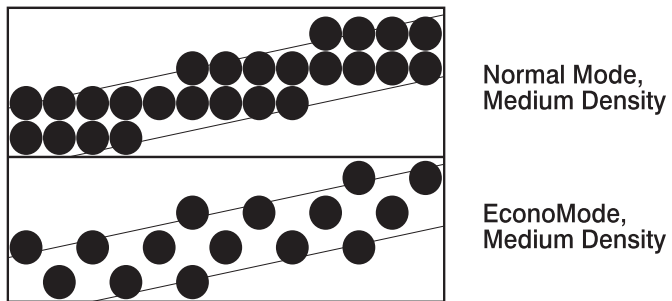

Figure 5-5 Normal Mode vs EconoMode

DC Controller System

The following systems and functions are controlled by the DC Controller PCA:

- DC Power Distribution (+5V DC, +12V DC, +24V DC)
- Laser and Scanner Drive
- Paper Motion Monitoring and Control (photosensors and flags)
- Clutches (registration, tray pickup, and Tray 1 feed)
- Engine Test
- Motors (Main Drive, Scanner, and Fans)

Figure 5-2 shows the Low Voltage Power Supply and Distribution System. See the wiring diagrams at the end of Chapter 7 for detailed listings of the DC Controller inputs and outputs.

Laser and Scanner Drive

Based on information received from the Formatter, the DC Controller sends signals to the Laser/Scanner Assembly to modulate the laser diode on and off and to drive the Laser/Scanner motor. See “Image Formation System” later in this chapter for more information.

Paper Motion Monitoring and Control

The DC Controller PCA controls paper motion by continuously monitoring the various paper sensors and coordinating paper movement with the other print processes.

Clutches

The drive signals for the Registration Assembly Clutch (CL1), Paper Input Unit Clutch (CL2), and the Tray 1 Feed Clutch are provided by the DC Controller PCA. The control signals for the clutches in the 2000-sheet Input Tray, Multibin Mailbox/5-bin Mailbox with Stapler, 2 x 500-sheet Input Tray, and 7-Bin Tabletop Mailbox are provided by the External Paper Handling PCA mounted on the Formatter Assembly.

Engine Test Microswitch

The Engine Test Microswitch, located on the DC Controller PCA, is activated manually through the square access hole at the right rear of the printer (see Chapter 6). This switch causes the print engine to perform an internal self test diagnostic which bypasses the Formatter PCA and then prints a full page of black parallel lines. This test is useful for troubleshooting printer problems because it isolates the print engine from the Formatter PCA. The engine test printout prints from Tray 3 and can be activated with the Formatter PCA removed. For more information, see Engine Test in Chapter 7.

Motors

See the General Timing Diagram (figure 5-23 on page 140) for specific timing details for the printer motors.

The Main Motor, **MT1**, is controlled by the DC Controller PCA. The Main Motor drives the Main Gear Assembly and rotates during the Initial Rotation period (following power-on), the Print period, the Last Rotation Period, or whenever the printer front door is opened and closed.

The Scanner Motor is controlled and monitored by the DC Controller. It rotates the laser/scanner mirror during the Initial Rotation period and the Print period.

The Fan Motors are controlled and monitored by the DC Controller PCA. All four fans operate at full speed during the printing modes. All four fans turn off in the PowerSave mode after the Fuser cools down.

The drive signal for the Tray 2 and 3 Paper Pickup Motor, **SMT1**, is provided by the DC Controller PCA through the Paper Input Unit (PIU) PCA mounted on the right side of the PIU. When the job instructions call for paper to be supplied by Tray 2, SMT1 rotates in a forward direction and drives the Pickup roller for Tray 2. When paper is supplied by Tray 3, SMT1 rotates in the reverse direction and drives the Pickup roller for Tray 3.

Image Formation System

Laser printing requires the interaction of several different technologies (such as electronics, optics, and electrophotographics) to provide a printed page. Each process functions independently and must be coordinated with the other printer processes. The image formation process consists of six steps:

- 1 Drum Cleaning
- 2 Drum Conditioning
- 3 Image Writing
- 4 Image Developing
- 5 Image Transferring and Media Separation
- 6 Image Fusing

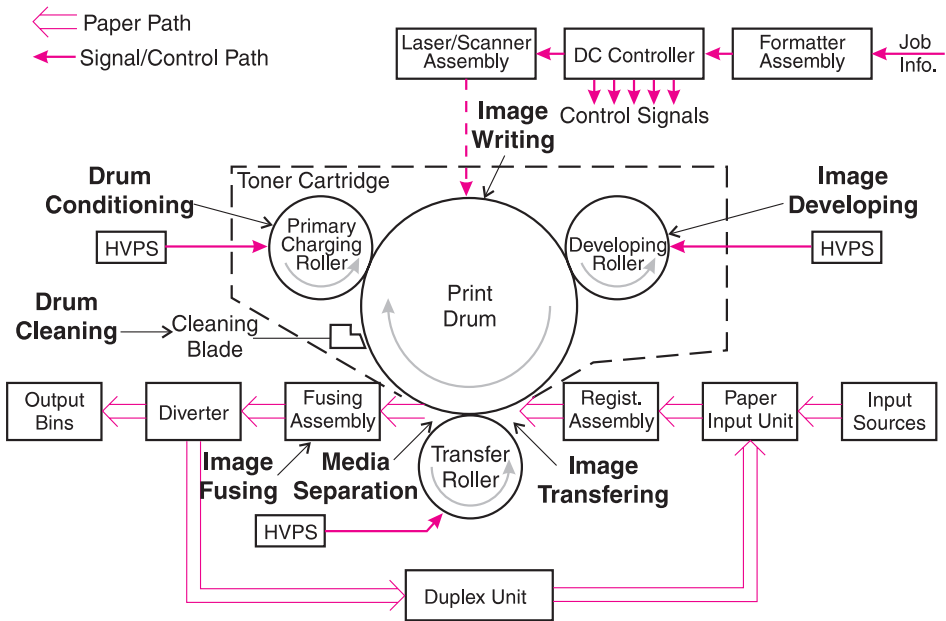

Figure 5-6 Image Formation Block Diagram

Toner Cartridge

The toner cartridge is the “heart” of the Image Formation System. It houses the cleaning, conditioning, and developing steps of the process. The toner cartridge contains the photosensitive drum, primary charging roller, developing station, toner cavity, and cleaning station. Including the components that wear, degrade, or are consumed in a customer-replaceable toner cartridge eliminates the need for a service call when replacement is required.

Toner Cartridge/High Voltage Power Supply Contacts

The toner cartridge has three contacts that route voltage from the HVPS PCA. They are:

- Upper: Primary Charge
- Middle: Developing Bias
- Lower: Toner Sensing/Toner Recognition

The Photosensitive Drum

The image from the Laser/Scanner Assembly is written on the drum surface, developed, and transferred to the media. The drum is an aluminum cylinder. The aluminum base of the photosensitive drum is electrically connected to ground potential. The outside of the cylinder is coated with a layer of non-toxic organic-photoconductive (OPC) material. The OPC material becomes electrically conductive when exposed to light. The drum surface is first cleaned of excess toner, then conditioned with a uniform negative charge. When an area on the drum surface is exposed to the laser light beam, the negative charge in that area is conducted to the ground potential of the drum base and thus becomes more positive. Areas not exposed to light remain non-conductive and maintain their negative charge.

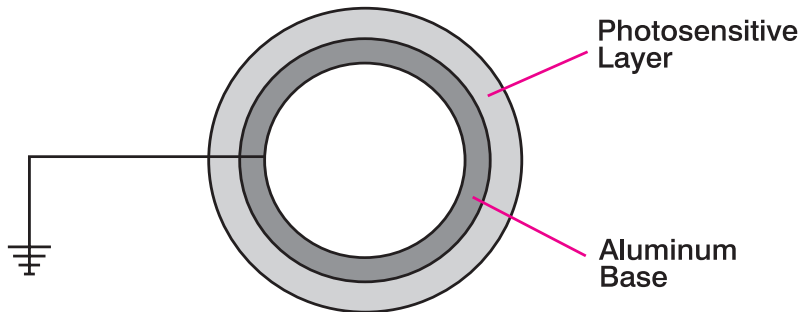

Figure 5-7 Photosensitive Drum

Drum Cleaning

The cleaning blade inside the toner cartridge is in contact with the surface of the drum at all times. As the drum rotates during printing, excess toner is removed from the drum surface and stored in the waste toner receptacle inside the toner cartridge.

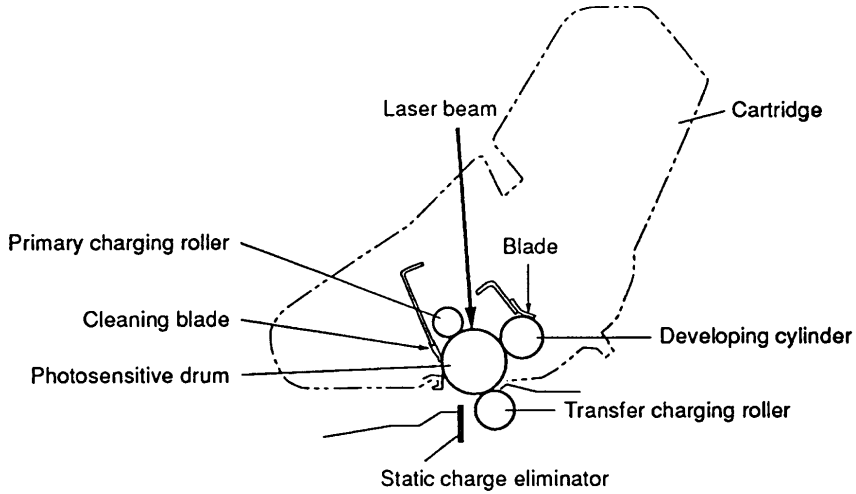

Figure 5-8 Drum Cleaning

Drum Conditioning

After the drum is physically cleaned, it is conditioned by applying a uniform negative charge across the surface of the drum with the primary charging roller, located in the toner cartridge. The primary charging roller is coated with conductive rubber, charged with an AC current that erases any residual charges, and produces a uniform drum surface potential. The AC current is centered around a negative DC bias which changes according to the Print Density setting.

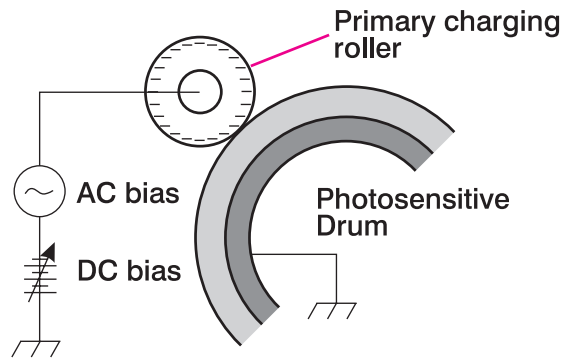

Figure 5-9 Primary Charging Roller

Image Writing

During the writing process, a modulated laser diode projects a beam onto a rotating six-sided scanning mirror. As the scanning mirror rotates, the beam is directed through a set of focusing lenses to another mirror that reflects it through a slot on the top of the toner cartridge and onto the photosensitive drum. The beam sweeps across the drum and discharges the negative potential wherever it strikes the surface. This creates a latent (invisible) electrostatic image, which is developed into a visible image as the drum rotates (see figure 5-10).

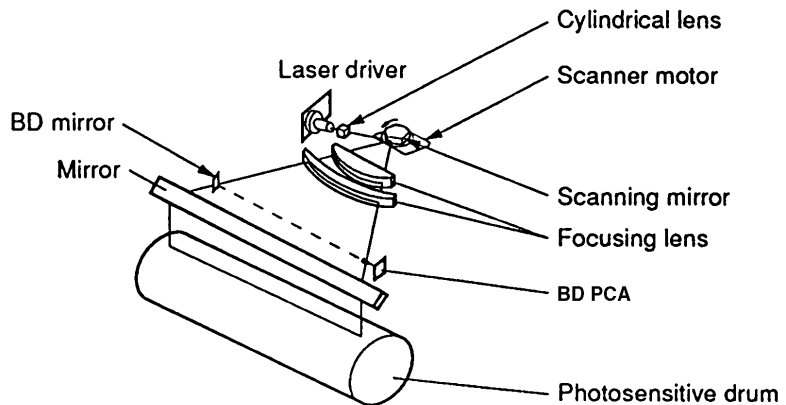

Figure 5-10 Image Writing

Because the beam is sweeping the entire length of the drum and the drum is rotating, the entire surface area of the drum can be covered. The speed of the laser/scanner motor (which turns the scanning mirror) and the speed of the main motor (which turns the drum) are synchronized, and each successive sweep of the beam is offset $1/600$ th of an inch. The beam can be turned on and off to place a dot of light every $1/600$ th of an inch. This is how the printer achieves its 600 x 600 dpi resolution. After the writing process, the drum surface has a latent (invisible) electrostatic image.

At the end of each sweep, the beam strikes the beam detect lens, generating the Beam Detect (BD) signal. The BD signal is sent to the DC Controller, where it is converted to an electrical signal used to synchronize the output of data (VDO) for one sweep (scan line) and to diagnose problems with the laser diode or laser/scanner motor.

Image Developing

The developing process changes the latent electrostatic image into a visible image by depositing negatively charged toner particles on the exposed areas of the drum. The developing station is located inside the toner cartridge and consists of a metallic cylinder that rotates around a fixed magnetic core.

The developing cylinder is charged with an AC current that is centered around a negative DC bias. The AC current improves density and contrast by decreasing the attraction between the toner particles and the magnetic core of the cylinder. This increases the repelling action of the toner against the areas of the drum not exposed to laser light. The negative DC bias applied to the developing cylinder is also changed according to the Print Density setting. Both the primary charging roller and developing cylinder DC bias voltages are changed in response to the density setting. These changes in DC bias cause either more or less toner to be attracted to the drum, thus increasing or decreasing print density.

The toner is a powdery substance made of black plastic resin bound to iron particles. The toner particles are attracted to the magnetic core of the developing cylinder. A rubber blade “brushes” the toner on the developing cylinder to a uniform thickness.

The toner particles obtain a negative static charge by rubbing against the developing cylinder, which is charged with a negative DC bias. The negatively charged toner is attracted to the discharged (exposed, more positive) areas of the drum and repelled from the negatively charged (non-exposed) areas.

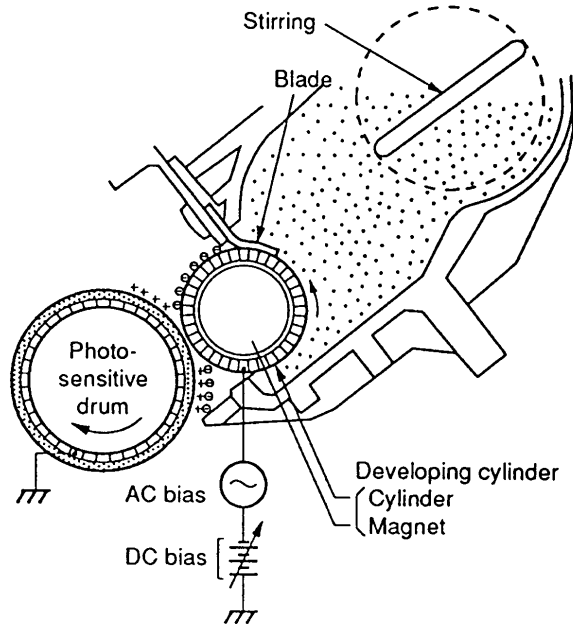

Figure 5-11 Image Development

Image Transferring and Media Separation

During the image transferring process, the toner image on the drum surface is transferred to the media. A positive charge applied to the back of the media by the transfer roller causes the negatively charged toner particles on the drum surface to be attracted to the media.

The small diameter of the drum, combined with the stiffness of the media, causes the media to separate easily from the drum. The static eliminator teeth also help separate the paper from the drum. The static eliminator teeth weaken the attractive forces between the negatively charged drum surface and the positively charged paper. This action keeps thin media from wrapping around the drum. After separation, the drum is cleaned and conditioned for the next image.

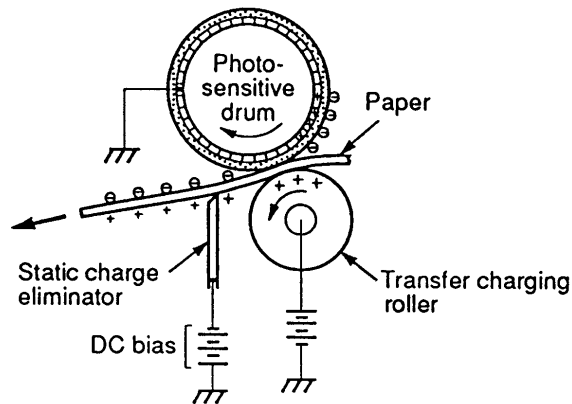

Figure 5-12 Image Transferring and Media Separation

Image Fusing

The Fusing Assembly bonds the toner particles into the media with a heated fusing roller and a soft pressure roller. There are two levers on the Fusing Assembly that adjust roller pressure for single sheets (down position) or envelopes (up position). Both levers must be set to the same position.

The fusing roller contains two quartz-halogen lamps that provide heat for the fusing process. Fusing temperature is monitored by the DC Controller PCA via thermistor TH1. The DC Controller maintains a temperature of about 190° C during print mode. If the fusing system overheats (about 230° C), TH1 opens, interrupting power to the fusing heater, causing a 50.X FUSER ERROR. If the fusing system exceeds 240° C, the thermal fuse opens, moving power away from the fuser.

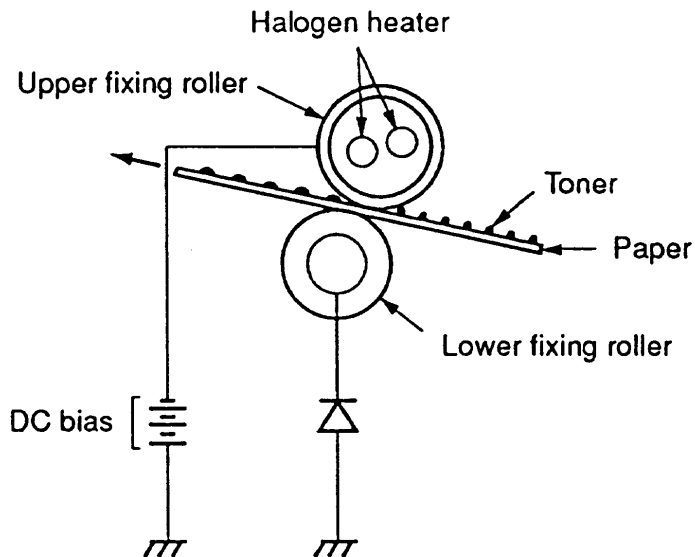

Figure 5-13 Image Fusing

Paper Paths and Components

Printer, Duplexer, and Envelope Feeder

The components of the printer paper path are illustrated in figure 5-14. Figure 5-15 and table 5-1 illustrate and describe all of the printer sensors, solenoids, clutches, motors, and fans.

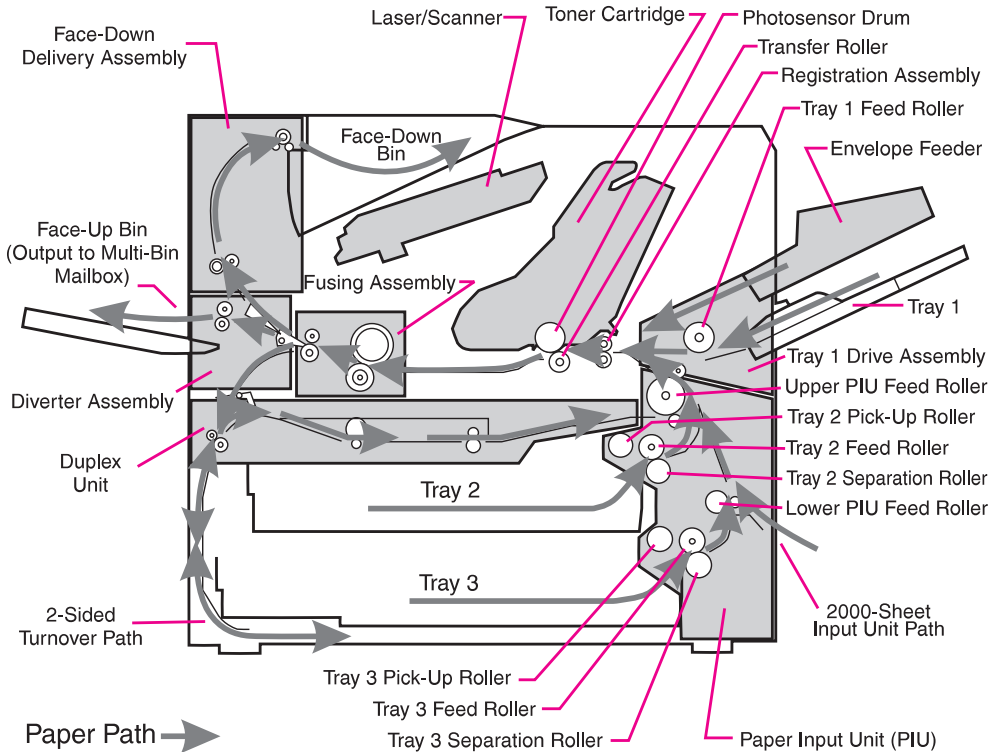

Figure 5-14 Printer Paper Paths

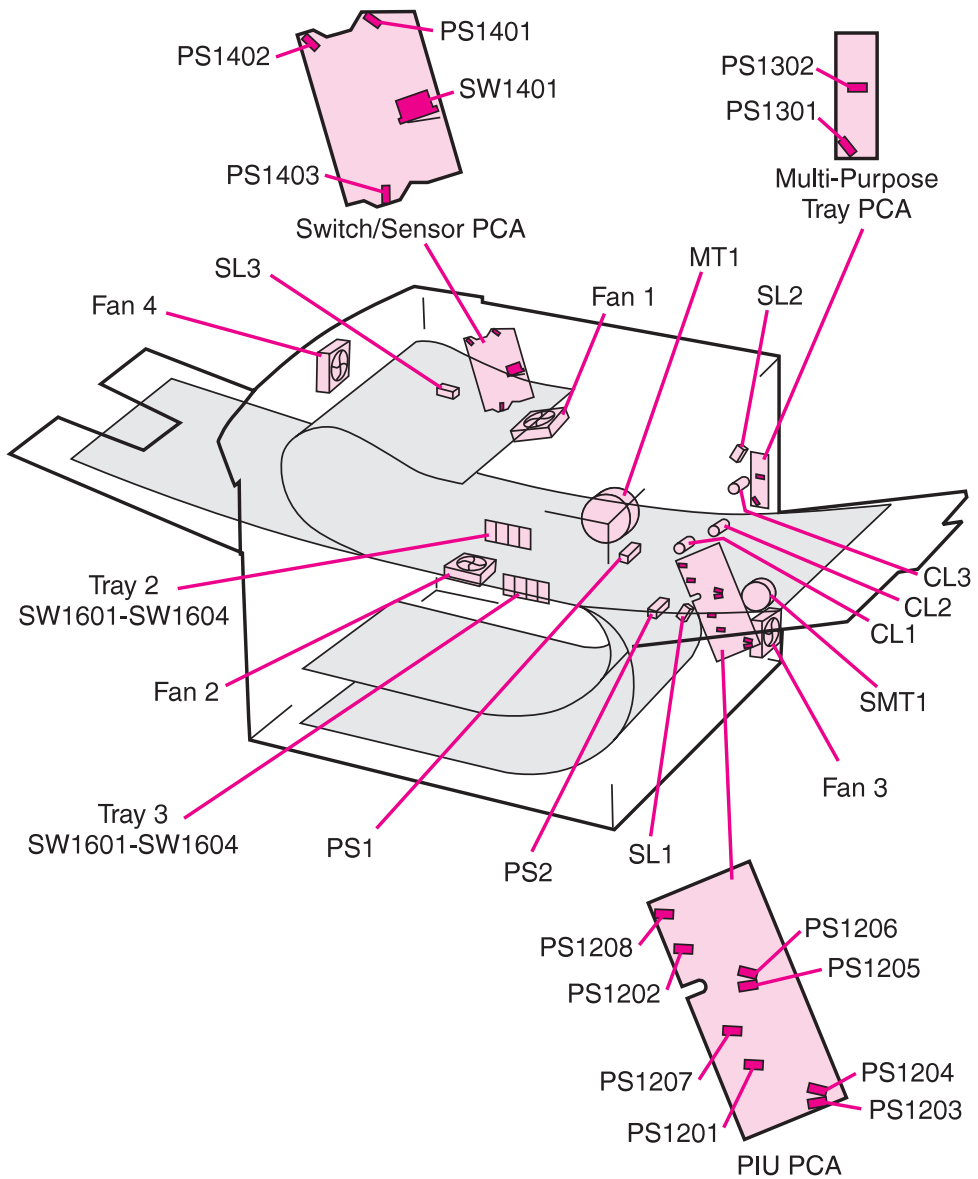

Figure 5-15 Printer Sensors, Solenoids, Clutches, Motors, and Fans

Table 5-1. Printer Sensors, Solenoids, Clutches, Motors, and Fans

Control Device	Title	Location
CL1	Registration Clutch	PIU (right side)
CL2	Paper Input Unit Feed Clutch	PIU (right side)
CL3	Tray 1 Feed Clutch	Tray 1 Drive Unit
Fan 1	Laser/Scanner Fan	Under Top Cover
Fan 2	Formatter Fan	LVPS
Fan 3	LVPS Fan	Below Formatter
Fan 4	Face-Down Delivery Unit Fan	Under Top Cover
MT1	Main Motor	Behind HVPS
PS1	Registration Paper Sensor	Registration Assembly (center)
PS2	Paper Input Unit Paper Sensor	Paper Input Unit (top, center)
PS1201	Tray 3 Paper Present Sensor	Paper Input Unit PCA
PS1202	Tray 2 Paper Present Sensor	Paper Input Unit PCA
PS1203	Tray 3 Paper Level Sensor 1	Paper Input Unit PCA
PS1204	Tray 3 Paper Level Sensor 2	Paper Input Unit PCA
PS1205	Tray 2 Paper Level Sensor 1	Paper Input Unit PCA
PS1206	Tray 2 Paper Level Sensor 2	Paper Input Unit PCA
PS1207	Tray 3 Paper Out Sensor	Paper Input Unit PCA
PS1208	Tray 2 Paper Out Sensor	Paper Input Unit PCA
PS1301	Tray 1 Paper Present Sensor	Tray 1 Drive Unit PCA
PS1302	Tray 1 Lifting Plate Position Sensor	Tray 1 Drive Unit PCA
PS1401	Face-Down Bin Full Sensor	Switch/Sensor PCA
PS1402	Face-Down Bin Delivery Sensor	Switch/Sensor PCA
PS1403	Fuser Delivery Sensor	Switch/Sensor PCA
SL1	Tray 2 and 3 Paper Pickup Solenoid	PIU (right side)
SL2	Tray 1 Lifting Plate Solenoid	Tray 1 Drive Unit
SL3	Left Output Bin Delivery Solenoid	Left Rear Corner of Chassis (behind diverter door)
SMT1	Tray 2 and 3 Paper Pickup Motor	PIU (right side)
SW1401	Doors Open Switch	Switch/Sensor PCA
Tray 2, SW1601	Tray 2 Paper Size Sensing Switch	Behind LVPS
Tray 2, SW1602	Tray 2 Paper Size Sensing Switch	Behind LVPS
Tray 2, SW1603	Tray 2 Paper Size Sensing Switch	Behind LVPS

Table 5-1. Printer Sensors, Solenoids, Clutches, Motors, and Fans (continued)

Control Device	Title	Location
Tray 2, SW1604	Tray 2 Paper Size Sensing Switch	Behind LVPS
Tray 3, SW1601	Tray 3 Paper Size Sensing Switch	Behind LVPS
Tray 3, SW1602	Tray 3 Paper Size Sensing Switch	Behind LVPS
Tray 3, SW1603	Tray 3 Paper Size Sensing Switch	Behind LVPS
Tray 3, SW1604	Tray 3 Paper Size Sensing Switch	Behind LVPS

2000-sheet Input Tray (Tray 4) Components

For information on this component, please refer to the *HP LaserJet 8000, 8000 N, 8000 DN, and HP Mopier 240 Printers Service Manual Supplement for Paper-handling Accessories*.

Multibin Mailbox Components

For information on this component, please refer to the *HP LaserJet 8000, 8000 N, 8000 DN, and HP Mopier 240 Printers Service Manual Supplement for Paper-handling Accessories*.

2 x 500-sheet Input Tray Components

Components of the 2 x 500-sheet Input Tray paper path are illustrated in figure 5-16 and described in table 5-2.

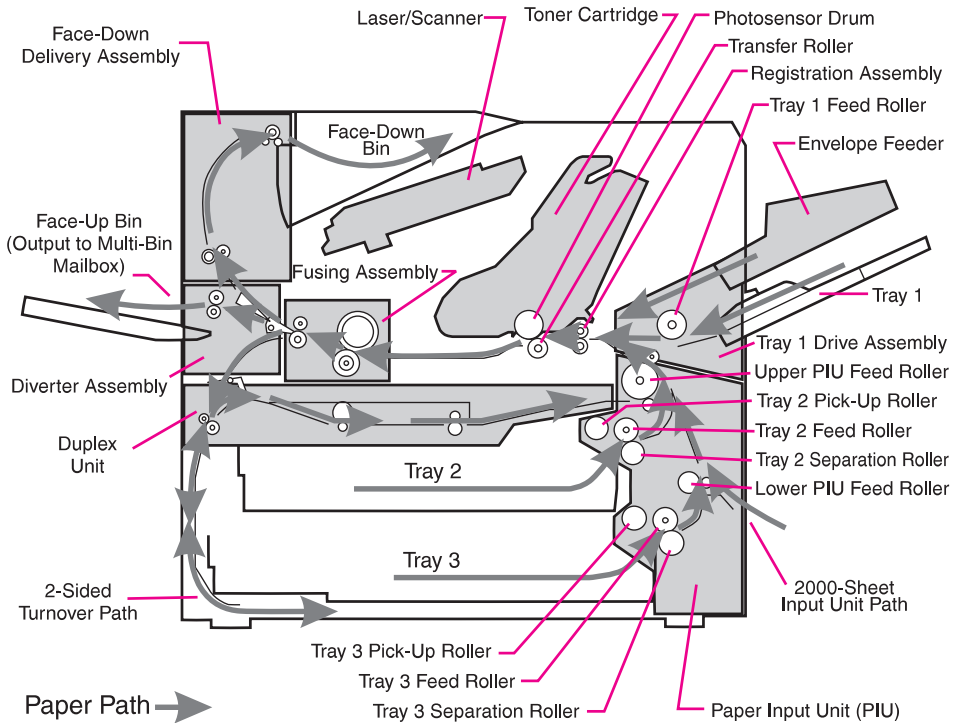

Figure 5-16 2 x 500-sheet Input Tray Paper Path

Table 5-2. 2 x 500-sheet Input Tray Switches

Paper Size	SW1601	SW1602	SW1603	SW1604
Ledger (Portrait)	OFF	OFF	OFF	OFF
A3 (Portrait)	OFF	ON	OFF	OFF
B4 (Portrait)	ON	OFF	OFF	OFF
Legal (Portrait)	ON	ON	OFF	OFF
Letter (Landscape)	OFF	OFF	OFF	ON
A4 (Landscape)	OFF	OFF	ON	OFF

2 x 500-sheet Input Tray Operation

The 2 x 500-sheet Input Tray is an input paper handling device that provides two additional input trays that hold up to 500 sheets each. The device is designed to support different printer platforms with variable engine input speeds, from 6 to 32 pages per minute, and provide storage space for printer supplies or consumables. The device has automatic paper size sensing and enhanced network management capabilities.

Communication and control of the input device are made through the Paper Handling Controller by a sequence of instructions controlled into the 2 x 500-sheet Input Tray controller PCA.

Pickup and Feed System

When the input device has been loaded and closed, the paper stack is lifted into position under the Pickup, Feed, and Separation rollers. The Pickup, Feed, and Separation rollers start rotating when the Paper Handling Controller sends a pickup command to the 2 x 500-sheet Input Tray. As the Pickup roller turns, the paper is fed into the vertical transfer unit and passes through the registration paper sensors. If the paper does not reach the sensors on time, the 2 x 500-sheet Input Tray controller assumes that a paper jam has occurred, stops the operation, and reports a delay jam to the Paper Handling Controller. A jam message will appear on the control panel display. If there is any hardware malfunction, it will be displayed on the control panel as well.

The paper guides in Trays 4 and 5 operate four levers at the back of the trays that activate the paper size sensing switches (SW1601 to SW1604).

Power Supply

The 2 x 500-sheet Input Tray has an internal power supply activated when the printer power switch has been turned on. The Paper Handling Controller sends a power-on signal to the power supply through the 2 x 500-sheet Input Tray controller. When the signal is high, the power supply provides +24V and +5V to the paper deck driver. The +24V is used to drive the lifter, Feed, Pickup motors, clutches, and solenoids; +5V drives sensors and PCA electronics.

7-bin Tabletop Mailbox Components

Components of the 7-bin Tabletop Mailbox paper path, including mailbox sensors, switches and motors, are illustrated in figure 5-17 and figure 5-18 and described in table below.

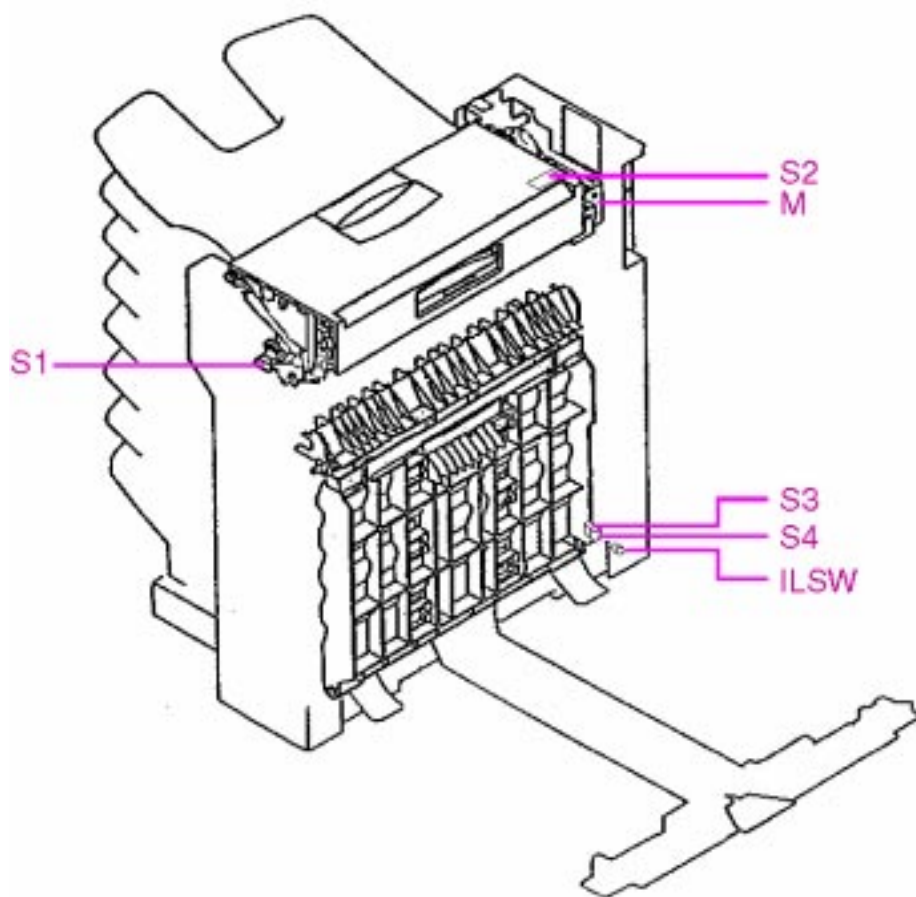

Figure 5-17 7-bin Tabletop Mailbox Components (1 of 2)

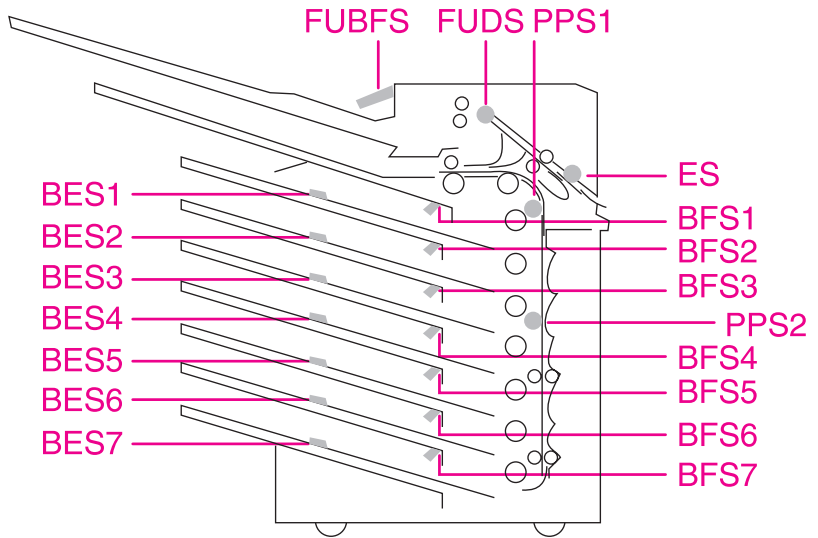

Figure 5-18 7-bin Tabletop Mailbox Components (2 of 2)

Table 5-3. 7-bin Tabletop Mailbox Sensors, Switches, and Motors

Control Device	Title	Location
M	Motor	Upper left side
S1	Face-up/Down diverter solenoid	Upper right side
S2	Reversing mechanism solenoid	Right side of the motor
S3	Diverter solenoid (1, 3, and 5)	Bottom left side
S4	Diverter solenoid (2, 4, and 6)	Bottom left side
BES1 to 7	Bin empty sensors (1 to 7)	Surface of every standard output bin
BFS1 to 7	Bin full sensors (1 to 7)	Upper left side of every standard output bin entrance
FUBFS	Face-up bin full sensor	Upper center of the left output bin entrance
ES	Paper entry sensor	Paper entrance
FUDS	Face up delivery sensor	Rev. assembly. (top cover)
PPS1	Paper path sensor 1	Inside the unit, down the entry rollers.
PPS2	Paper path sensor 2	Paper path (back cover)
ILSW	Interlock switch	Bottom back left side

7-bin Tabletop Mailbox Operation

The 7-Bin Tabletop Mailbox (MBM-7) is a low cost output device designed to support different printer platforms at variable engine input speeds and to increase office productivity. The mailbox has a total capacity of 940 sheets distributed in 7x120 standard output bins and a 1x100 left output bin, and works with four intelligent and configurable operating modes.

An additional optional product, the Stand for the 7-bin Mailbox, allows the customer to attach the mailbox in a floor stand configuration when an input device is attached to the printer.

Operating Modes

Configurable Mailbox (Default Configuration)

In this mode, each bin can be addressed individually as the output destination and can have a name assigned to it by the network or mopier administrator. All the jobs are placed in the standard output bins. If the assigned bins are full, the printer halts or sends the next pages to the overflow bin, as defined by the MIS manager.

Job Separation

This mode automatically separates incoming jobs and assigns a bin to each job, which may include multiple copies. It uses all mailbox bins for this purpose, starting at the first standard output bin (at top), but is seen in the mopier software as one logical bin. If a mailbox bin is full, the mopier automatically sends the job to the next available bin or the overflow bin. If there are more jobs than bins, the following job will start again at the first available standard output bin from the top.

Configurable Stacker

This mode stacks the printed output from the lowest bin to the top, regardless of job boundaries. This mode of operation takes advantage of the total capacity of the mailbox bins. The software sees the mailbox as one logical bin. When the mailbox is full, the system will halt until all bins are emptied.

Collator

In this mode, the mailbox automatically separates mopies. Each mopy is delivered in consecutive bins, starting from the top standard output bin. In this case, one job contains several mopies.

Configuring the Operating Modes

The network administrator chooses the mode of operation through an HP network configuration utility, such as HP JetAdmin or HP LaserJet utility. You must set up your printer driver to reflect the mode chosen by the administrator.

Bidirectional Environment

The printer automatically selects the mode established by the network administrator.

Non-bidirectional Environment

You can change the mode in the driver. The method for changing the mode varies by driver and by operating system. Refer to your driver's online help.

Receiving Paper

The engine delivers paper to the mailbox through the face-up delivery slot (input paper guide) at 107 mm/sec. The entry sensor (ES) senses paper arrival, and then the face-up/down diverter solenoid actuates only if the paper is going to the left output bin. If the paper has to reach any standard output bin, this solenoid will not actuate and the paper will go into the reversing area.

Delivering Paper

If the paper is going to the left output bin, the face-up delivery sensor (FUDS) waits for the paper to reach the left output bin. When the bin is full, the paper will actuate the left output bin full sensor (FUBFS).

If the paper is sent to any of the standard output bins, the reversing mechanism will be activated by the reversing mechanism solenoid (S2). The paper path sensor 1 (PPS1) will wait for paper, and the correct diverter solenoid will actuate to deliver the paper in the correct bin (S3 if the paper is going to bin numbers 1 through 3 or S4 for bin number 2).

If the paper has to reach other bins, then the paper path sensor 2 (PPS2) will be waiting for it. In the same way, S3 will be activated if the paper final destination is bin number 5, and if not, then S4 will be activated to reach bins 4 through 6. Finally, if the paper destination is bin number 7, none of the solenoids will be actuated. When a specific bin is full, then the paper will actuate the corresponding standard output bin full sensor (BFS1 to 7). The unit can report an empty bin condition to the engine based on the empty bin sensors (BES1 to 7).

Power-on Sequence

During the power-on sequence, the mailbox runs an initialization routine. The motor will perform a complete cycle and solenoid S2, S3, and S4 will be activated in that order. At the end of this routine, the front cover LED will display a fixed green light, but if there is a problem, the LED will flash red.

Communication Link

Communication Link (C-link) devices include:

- C-link Input Devices:
 - 2000-sheet Input Tray
 - 2 x 500-sheet Input Tray
- C-link Output Devices:
 - 8-bin Multibin Mailbox
 - 5-bin Multibin Mailbox with Stapler (Includes a Finisher)
 - 7-bin Tabletop Mailbox

Communication and control of the C-link devices is through the paper handling controller mounted on the printer's formatter PCA. The C-link devices (C-link protocol) have their own power supply and controller board that receives signals and commands from the paper handling controller. This communication is illustrated in figure 5-19.

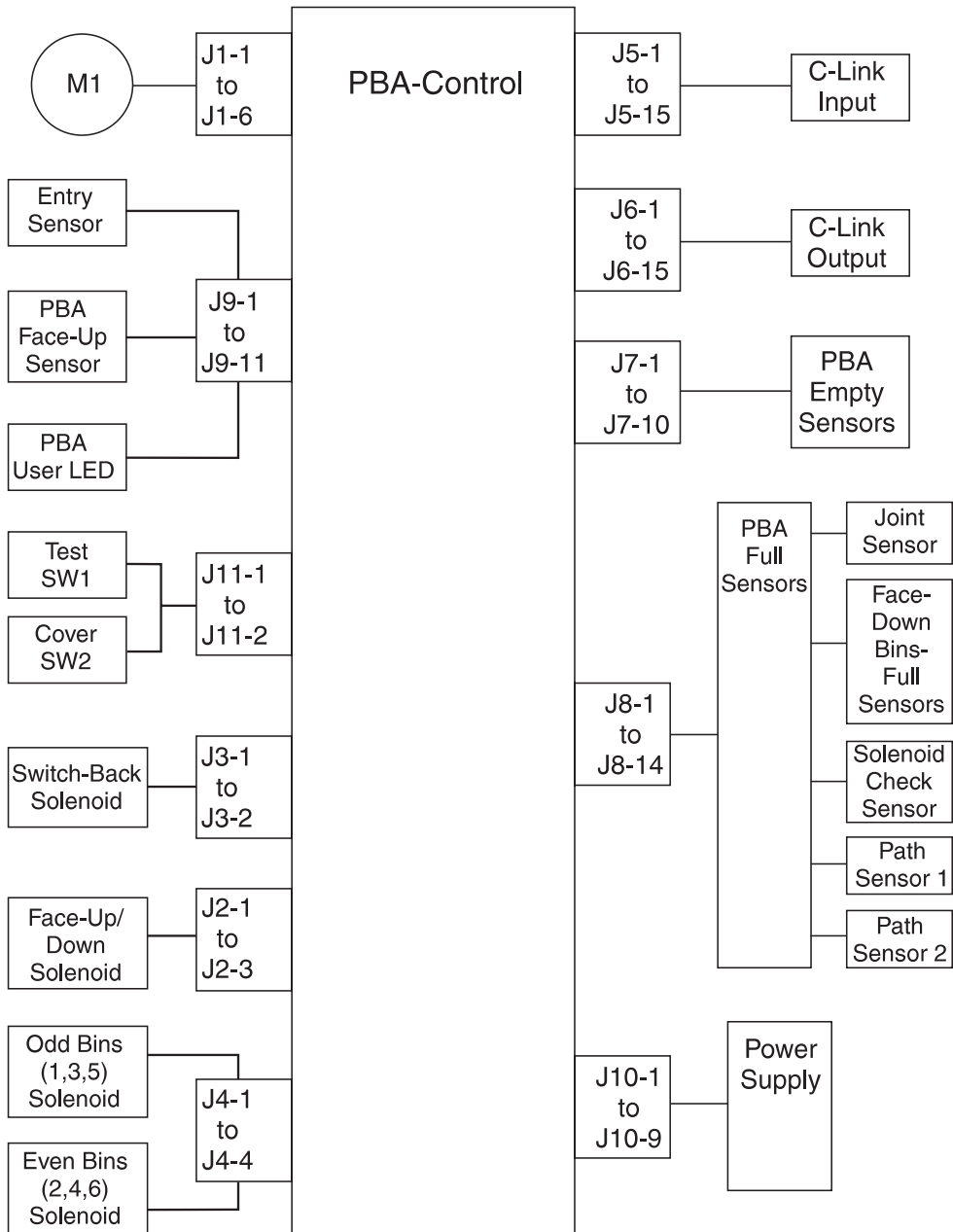

Figure 5-19 C-link Connection

The information from the paper handling controller is carried by the C-link cables that connect the controller board for all of the C-link protocol-supported devices. The C-link protocol supports up to 5 devices connected to the paper handling controller in a Daisy Chain. Each device controller has an input and output port that provides them the flexibility of connection in different configurations. However, HP recommends using the configuration shown in figure 5-20 to avoid rearrangements in the supported device numbering and confusion when evaluating the event log.

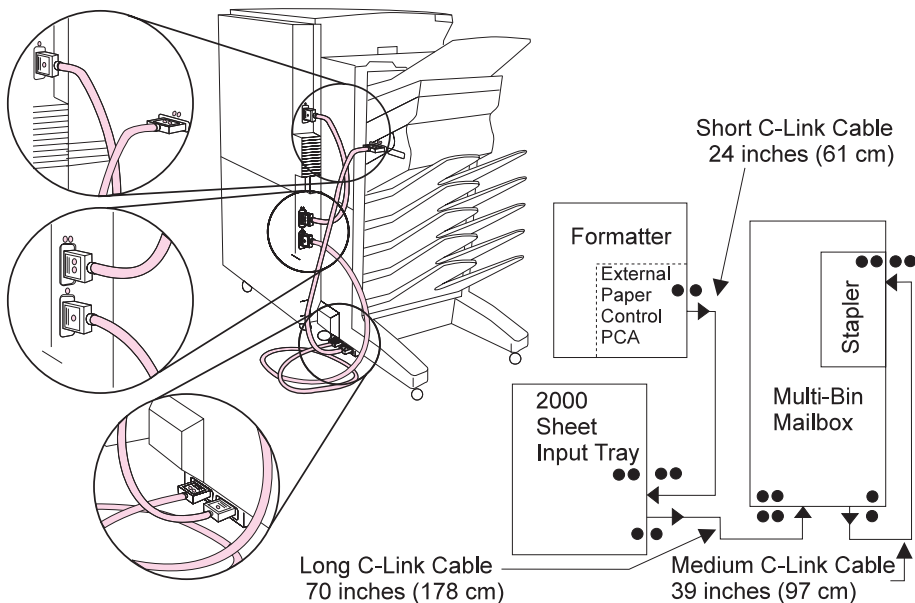

Figure 5-20 C-Link Configuration (Recommended)

Stapler Components

The 5-bin Mailbox with Stapler is a multi-function stand, output paper-handling device designed to work with different HP LaserJet printers. It has both mailbox and stapling capability. The stapler unit output bin staples up to 20 sheets (20-lb paper) and has a total capacity of 350 stapled sheets.

In addition, this component has 5 standard output bins with a capacity of 250 sheets and 1 left output bin with a capacity of 100 sheets, for a total capacity of 1350 non-stapled sheets. The Multibin Mailbox (8-bin) and the 5-bin Mailbox with Stapler have similar functionality, performance, and parts. The stapler fits into the Multibin Mailbox by removing the three upper bins.

The assemblies and subassemblies of the stapler are listed in table 5-4. The motors, sensors, and switches are illustrated and described in figure 5-21 and table 5-5.

Table 5-4. Stapler Major Assemblies and Subassemblies

Major Assembly	Subassemblies
Stapler bed Assembly	Retainer Assembly
	Sliders Assembly
Top Cover Assembly	Stapler Assembly
	Rack Assembly Registration Pusher Off-Set Pusher
	Exit Flap Assembly
Housing	Output Bin
	Bin Full Sensor Actuator
	Wire Frame
Stapler Controller PCA	N/A

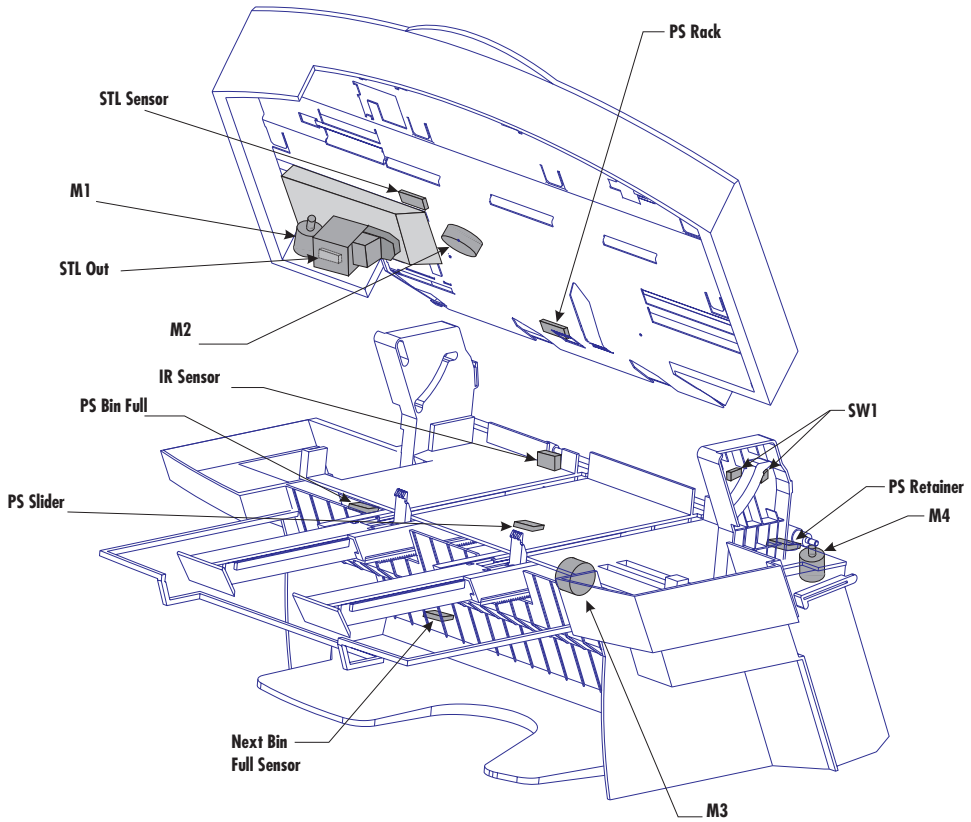

Figure 5-21 Stapler Motors, Sensors, and Switches

Table 5-5. Stapler Motors, Sensors, and Switches

Control Device	Title	Location
M1	Stapler DC Motor	Stapler Assembly
M2	Rack Stepper Motor	Top Cover Assembly
M3	Slider Stepper Motor	Top Cover Assembly
M4	Retainer DC Motor	Stapler bed Assembly
IR Sensor	Infra Red Sensor	Stapler bed Assembly
STL Sensor	Stapler Sensor	Stapler Assembly
PSRack	Rack Sensor	Top Cover Assembly
PSSlider	Slider Sensor	Stapler bed Assembly
PSRetainer	Retainer Sensor	Stapler bed Assembly

Table 5-5. Stapler Motors, Sensors, and Switches (continued)

Control Device	Title	Location
PSBinFull	Output Bin Full Sensor	Stapler bed Assembly
PSNBinFull	Next Bin Full Sensor	Housing
STLout	Staples Out	Stapler Assembly
SW1	Top Cover Interlock Switches (2 in serial)	Right Hinge

5-bin Mailbox with Stapler Operation

All communication and control of the mailbox, the 2000-sheet Input Tray, and the stapler is through the Paper Handling Controller. These instructions are sent to the stapler controller PCA located in the lower part of the stapler. The main components of the stapler are listed in table 5-4. Power is provided to the stapler by the Multibin Mailbox/ 5-bin mailbox with Stapler external 24V DC power supply through the C-link 5-bin cable. The stapler is mounted in the Multibin Mailbox/ 5-bin Mailbox with Stapler, replacing the three standard output bins. It handles letter and A4 sizes of plain paper. The stapler can staple up to a maximum of 20 sheets.

Main Functional Cycles of the Stapler

The stapler cycles are described in the following paragraphs and illustrated in figure 5-22.

Paper Feed Cycle

The stapler bed assembly receives the paper from the Multibin Mailbox/5-bin Mailbox with Stapler Head assembly. The IR Sensor detects when the paper arrives in the stapler. The Retainer (a shaft holding two rubber flexible fingers or anti-curl fingers) rotates once to apply pressure down and backward. This action forces the paper to register against the rear wall of the stapler bed, as well as reduces paper curl. The Registration Pusher (located in the right side of the Top Assembly) registers the paper against the left wall of the stapler bed. This cycle is repeated until the amount of sheets to be stapled is reached (with a maximum of 20).

Stapling Cycle

The Sliders move the stack of sheets to the stapling position. The Registration Pusher applies slight pressure to the stack of sheets toward the left wall of the stapler bed where the stapler is located. Then the stack of sheets is stapled.

Eject Cycle

The stapler bed sliders offset the stacks or jobs. The Off-Set Pusher (located in the left side of the Top Cover Assembly) pushes the stack towards the right side of the stapler bed, whenever it applies. The Sliders move the stack of paper from stapling position to eject position, which is out of the stapler bed (reaching the Wire Frame level). The Wire Frame directs the stack of paper. The Exit Flap Assembly moves down to prevent the job from returning to the stapler bed. The Sliders retract to home position, letting the stack of sheets fall into the output bin. The capacity of the output bin is 300 stapled sheets in jobs of five sheets or equivalent combinations.

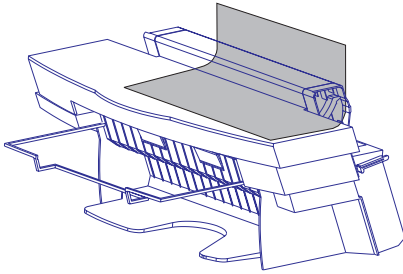

PAPER FEED CYCLE

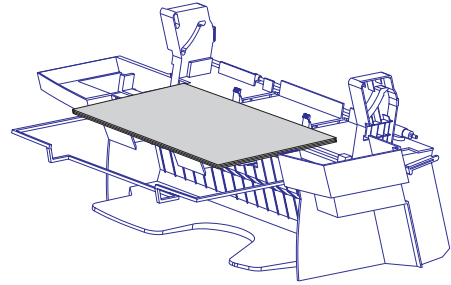

STAPLING CYCLE

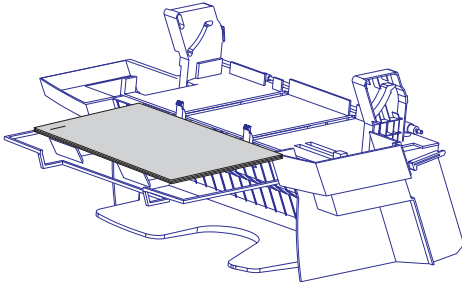

EJECT CYCLE

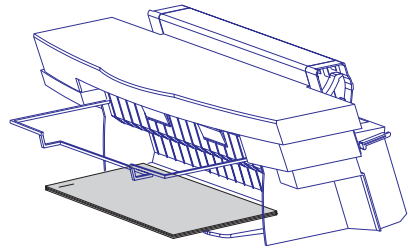

STACKING

Figure 5-22 Stapler Cycles

Power-On or Reset Sequence

At power-on or reset, events are performed in the following sequence:

- 1 Stapler Assembly is set to a ready state.
- 2 Retainer Assembly is turned to its initial position.
- 3 Rack Assembly is moved to find its home position, which is in the left side of the Top Cover Assembly.
- 4 Slider Assembly is moved to find its home position, which is inside of the stapler bed.
- 5 Slider Assembly is moved fully out from the stapler bed to the eject position.
- 6 Rack Assembly is moved to activate the Exit Flap Assembly.
- 7 Slider Assembly is moved to its home position.
- 8 Rack Assembly is returned to its home position.

Printer Input Sources

Paper Size Switches

The paper guides in Trays 2 and 3 operate four levers at the back of the trays that activate the size sensing switches (SW1601 through SW1604) mounted in the printer chassis. Paper sizes are compared to switch conditions in table 5-6.

Table 5-6. Paper Size Switches

Paper Size	SW1601	SW1602	SW1603	SW1604
Ledger (portrait)	OFF	OFF	OFF	OFF
A3 (portrait)	OFF	ON	OFF	OFF
B4 (portrait)	ON	OFF	OFF	OFF
Legal (portrait)	ON	ON	OFF	OFF
Letter (landscape)	OFF	OFF	OFF	ON
A4 (landscape)	OFF	OFF	ON	OFF

Printing from Trays 2 and 3

The Pickup, Feed, and Separation rollers start rotating when the DC Controller receives the /PRNT signal from the Formatter PCA. Then, the DC Controller activates the Pickup Solenoid (SL1) and starts feeding paper through the Paper Input Unit (PIU), triggering photosensors PS2 and then PS1. These sensors inform the DC Controller that paper has passed through the PIU and is present at the Registration Assembly.

When the Laser/Scanner and Fuser are ready, the DC Controller sends the /VSREQ signal to the Formatter. When the Formatter has processed the print data, it sends the /VSYNC and /VDO signals to the DC Controller. The paper is then released from the Registration Assembly (by CL1) and fed to the photosensitive drum, starting the image transfer and fusing processes. After the paper passes through the Fuser, it triggers PS1403 and PS1402 to the specified type, size, and destination of the paper being fed through the printer.

Printing from Tray 1

The presence of paper in Tray 1 is detected by the Tray 1 Paper Present Sensor (PS1301). The lifting plate pressurization solenoid (SL2) is then activated, releasing the plate that applies upward pressure on the paper and causing it to contact the Tray 1 pickup roller. The Tray 1 Feed Clutch (CL3) turns on at this time and feeds the paper from Tray 1 to the registration position.

The remainder of the Tray 1 print process is identical to the Tray 2 and 3 process, described in “Printing from Trays 2 and 3” on page 136.

Printing from the Envelope Feeder

The Envelope Feeder mounts in slots above Tray 1. The printer can print from Tray 1 when the Envelope Feeder is installed. When the print job calls for an envelope, it is fed directly to the Registration Assembly. From there, the print process is identical to the Tray 2 and 3 process, described in “Printing from Trays 2 and 3” on page 136.

Printing from the 2000-sheet Input Tray (Tray 4) or 2 x 500-sheet Input Tray (Trays 4 and 5)

Trays 4 and 5 feed the paper upward through a guide slot in the Lower Right Door Assembly to the Paper Input Unit. Once there, the operation is the same as printing from Trays 2 and 3, described in “Printing from Trays 2 and 3” on page 136.

Two-Sided Printing

The duplexer mounts inside the printer below the Fusing Assembly. The back side of the paper is printed first, the paper is turned over, and then fed back to the Registration Assembly for front side printing. When the print job calls for 2-sided printing, a solenoid in the duplexer operates the duplex flipper in the Diverter Assembly and routes the paper to the duplexer. The paper does not exit the printer when being turned over for 2-sided printing. It is routed through a slot in the back of the duplexer, down inside the left cover and under Tray 3. When the duplexer senses the trailing edge of the paper, it reverses direction and feeds the paper back through the duplexer to the Registration Assembly.

Paper Jam Detection

The PIU Sensor (PS2), the Registration Sensor (PS1), the Fuser Delivery Sensor (PS1403), and the Face-Down Delivery Sensor (PS1402) detect paper moving through the printer (see figure 5-15 on page 118 and table 5-1 on page 119 for a description of each sensor and illustration of its locations). If a paper jam is detected, the DC Controller immediately stops the printing process and causes a 13.x PAPER JAM message to be displayed on the control panel. If a paper jam occurs in the Envelope Feeder, duplexer, 2000-sheet Input Tray, Multibin Mailbox/5-bin Mailbox with Stapler, 2 x 500-sheet Input Tray, or 7-bin Tabletop Mailbox, the 13.x Paper Jam message will indicate the approximate location. See Chapter 7 for more details.

Printer Timing

The Formatter PCA and the DC Controller PCA share information during printer operation. This information consists of printer status, command, and dot-image data. Figure 5-23 and figure 5-24 show the general timing of the printer events. Table 5-7 lists the events that take place during normal printer operation.

Table 5-7. Printer Timing

Period	Timing	Purpose
WAIT	From power on to the end of Main Motor initial rotation.	Clear the drum surface potential and clean the Transfer Roller.
STBY (standby)	From the end of the WAIT or the LSTR period until the input of the PRNT signal from the Formatter PCA. Or from the end of the LSTR period to power off.	Maintain the printer in the READY state.
INTR (initial rotation)	From the input of the PRNT signal from the Formatter PCA until the laser diode intensity has been stabilized.	Stabilize the photosensitive drum sensitivity in preparation for printing. Clean the Transfer Roller.
PRNT (print)	From the end of the initial rotation until the Scanner Motor stops.	Form images on the photosensitive drum based on the /VDO signal from the Formatter PCA. Transfer the image to the media.

Table 5-7. Printer Timing (continued)

Period	Timing	Purpose
LSTR (last rotation)	From the primary voltage (DC) off until the Main Motor stops. If another PRNT signal is sent from the Formatter PCA, the printer returns to the INTR period. If not, it returns to the STBY period.	Deliver the last sheet of paper and clean the Transfer Roller.

• Timing chart for two consecutive prints on A4 horizontal paper (Lower cassette feed - face-down tray delivery)

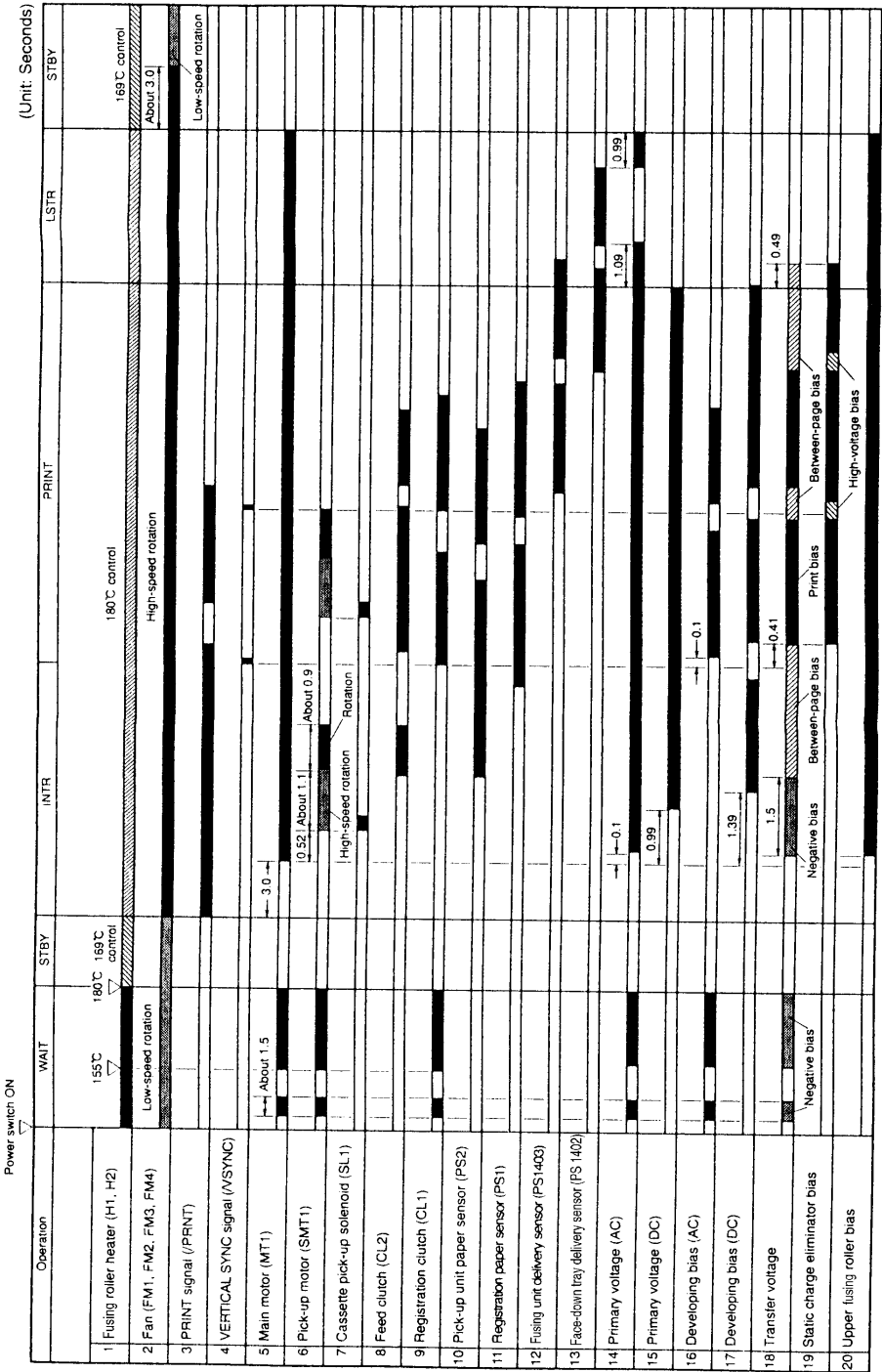

Figure 5-23 General Timing Diagram (1 of 2)

• Timing chart for two consecutive prints on A4 horizontal paper (Duplexing feed)

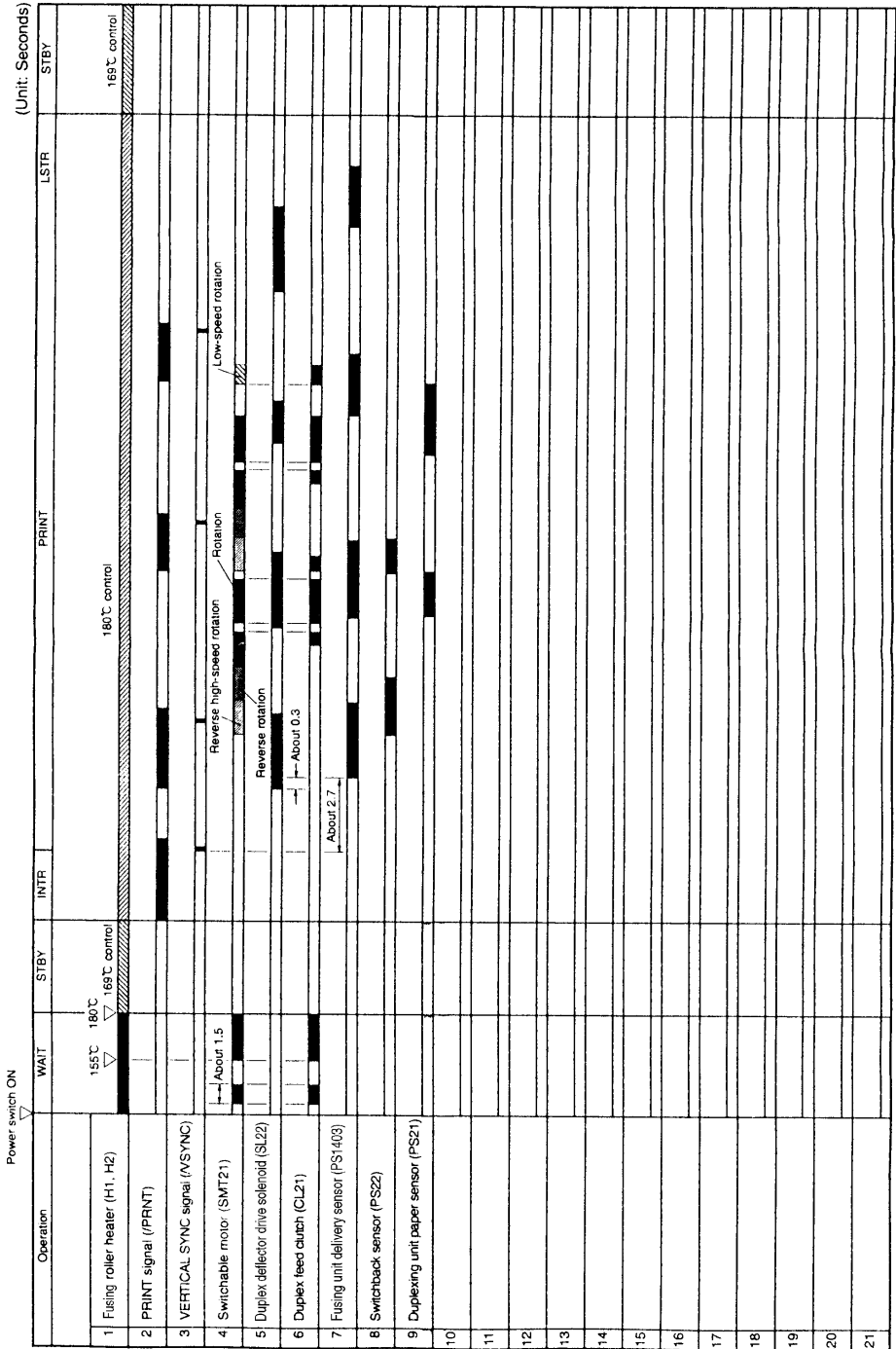

Figure 5-24 General Timing Diagram (2 of 2)

IEEE 1284 Parallel Cable Information

This cable is IEEE compliant with A-to-C connectors. To take advantage of its enhanced capabilities such as bi-directional communication between the computer and printer, faster transmission of data, and auto configuration of printer drivers, the customer must have the following:

- Support in software applications for these features.
- A parallel cable with the correct pin configuration (see figure 5-25).

Parallel Cable Pin Configuration

For best results, use the C2946A (3 meter) or C2947A (10 meter) cable or equivalent.

CAUTION

Ensure that all power and interface cables on the printer and host computer are properly grounded in compliance with local codes.

Signal Name	Printer Pin #	IBM Port Pin #
nSTROBE	1	1
DATA 1	2	2
DATA 2	3	3
DATA 3	4	4
DATA 4	5	5
DATA 5	6	6
DATA 6	7	7
DATA 7	8	8
DATA 8	9	9
nACKNLG	10	10
BUSY	11	11
CALL (PE)	12	12
SELECT	13	13
nAutoFd	14	14
No Connect	15, 34	
O VDC (GND)	16, 19 THRU 30	18 THRU 25
nIP	31	
nFAULT	32	15
Vcc	33	
Vcc	35	

Figure 5-25 Parallel Cable Pin Assignments (C2946A)

6 Removal and Replacement

Chapter contents

Removal and Replacement Strategy - - - - -	145
Required Tools- - - - -	146
User Installable Accessories - - - - -	147
Hardware Table - - - - -	157
Control Panel - - - - -	159
Covers- - - - -	160
Delivery Unit (for Standard Output Bin) - - - - -	169
Diverter Assembly - - - - -	172
Door Assembly, Diverter - - - - -	173
Door Assembly, Right Lower - - - - -	174
Fan 1, Exhaust (Laser/Scanner) and Housing- - - - -	177
Fan 2, Exhaust (LVPS) - - - - -	179
Fan 3, Intake (Formatter) and Housing - - - - -	180
Fan 4, Exhaust (Delivery Unit) - - - - -	182
Feeder Assembly - - - - -	183
Formatter Assembly - - - - -	185
Fusing Assembly- - - - -	187
Laser/Scanner Assembly- - - - -	189
Main Gear Assembly - - - - -	191
Main Motor Assembly - - - - -	194
Paper Input Unit (PIU) - - - - -	195
PCA, DC Controller - - - - -	197
PCA, Output Paper Sensor- - - - -	198

Power Supply, High Voltage (HVPS) - - - - -	205
Power Supply, Low Voltage (LVPS) - - - - -	206
Registration Assembly - - - - -	207
Roller and Separation Pad, Tray 1- - - - -	210
Rollers: Tray Pickup, Feed, and Separation - - - - -	212
Sensor, Paper Input Unit (PS2) - - - - -	214
Sensor, Registration (PS1) - - - - -	216
Solenoid Assembly, SL3 (Face-Up) - - - - -	218
Transfer Roller Assembly - - - - -	219
Tray 1 Assembly - - - - -	221
Tray 2 and 3 Assemblies - - - - -	222
Mailbox With Stapler - - - - -	223
Stapler Assembly- - - - -	249
7-bin Tabletop Mailbox - - - - -	259
2 x 500-sheet Input Tray - - - - -	295

Removal and Replacement Strategy

This chapter documents the removal and replacement of major assemblies.

Replacement is generally the reverse of removal. Occasionally, directions for difficult or critical replacement procedures are included.

WARNING!

Unplug the power cord from the power outlet before attempting to service the printer. If this warning is not followed, severe injury may result.

Never operate or service the printer with the protective cover removed from the Laser/Scanner assembly. The reflected beam, although invisible, can damage your eyes.

This printer has some sharp sheet metal edges that can cause injury.

CAUTION



The printer contains parts that are electrostatic discharge (ESD) sensitive. Always service printers at an ESD protected workstation. Watch for the ESD reminder shown at left while performing removal procedures.

Required Tools

- #2 magnetized Phillips screwdriver (6-inch shaft)
- Small flat-blade screwdriver
- Small pair needle-nose pliers
- T-15 Torx driver (6-inch shaft)

All components in the printer, the 2000-sheet Input Tray, and the 2 x 500-sheet Input Tray use Phillips head screws that require a #2 size Phillips screwdriver. Figure 6-1 shows the difference between a Phillips and a Posidriv screwdriver. Note that the Phillips tip has more beveled surfaces.

All screws used in the field-replaceable Multibin Mailbox/5-bin Mailbox with Stapler and 7-bin Tabletop Mailbox components require a T-15 Torx driver.

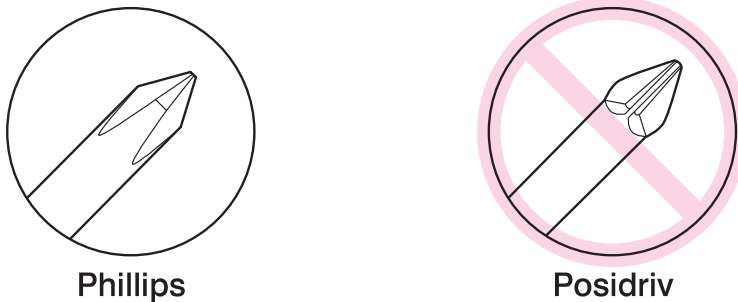

Figure 6-1 Phillips vs. Posidriv Screwdrivers

Note

See table 6-1 on page 157 and Chapter 8 for a list of the screws and other common hardware used in the printer.

CAUTION

To install a self-tapping screw, first turn it counter-clockwise to align it with the existing thread pattern, then carefully turn clockwise to tighten. Do not over-tighten. If a self-tapping screw-hold becomes stripped, repair of the screw-hole or replacement of the affected assembly is required.

User Installable Accessories

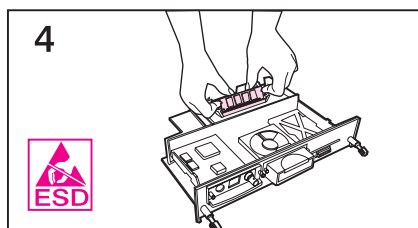
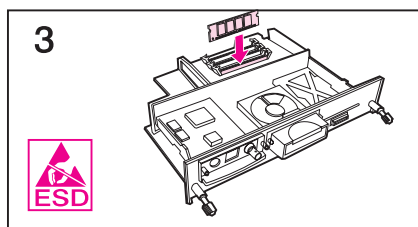
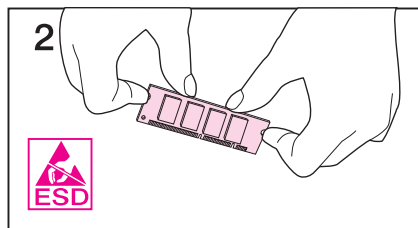
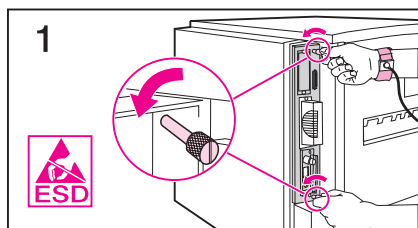

Memory and Personality Upgrade

CAUTION

DIMMs and the Formatter PCA can be damaged by small amounts of electrostatic discharge (ESD). Wear an anti-static wrist wrap.

Print a configuration page (page 342).

- 1 Turn the printer off. Unplug the power cord, and disconnect any cables.

Loosen the two captive thumb screws on the back of the printer. Grasp the screws and pull the formatter board out of the printer. Place it on a flat, non-conductive surface.

- 2 Remove the DIMM from the antistatic package. Hold the DIMM with fingers against the side edges and thumbs against the back edge. Align the notches on the DIMM with the DIMM slot. (Check that the locks on each side of the DIMM slot are open, or outward.)
- 3 Press the DIMM straight into the slot (press firmly).
- 4 Make sure the locks on each side of the DIMM snap inward into place. (To remove a DIMM, the locks must be released.)

Slide the formatter board back into the printer, and tighten the two screws. Plug in the power cord and connect all cables. Turn the printer on.

Disk Drive

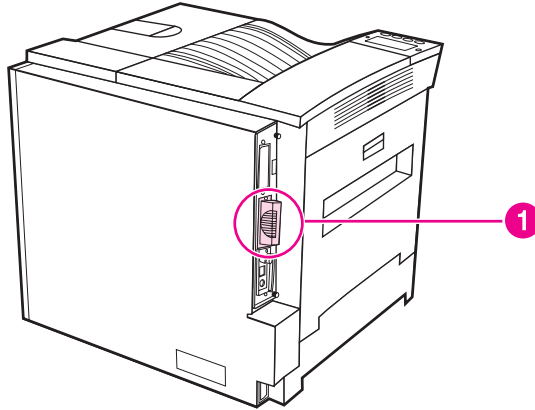

Figure 6-2

Disk Drive

To remove the disk drive:

- 1 Turn the printer off, and unplug it.
- 2 Loosen the 2 captive screws, and remove the disk drive from slot #2 (figure 6-2, callout 1).

To reinstall the disk drive:

- 1 Turn the printer off.
- 2 Install the disk drive in slot #2 (figure 6-2, callout 1), and tighten the 2 captive screws.
- 3 Print a configuration page to verify the settings.

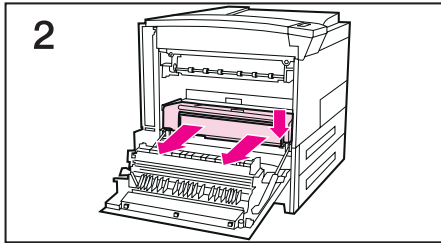
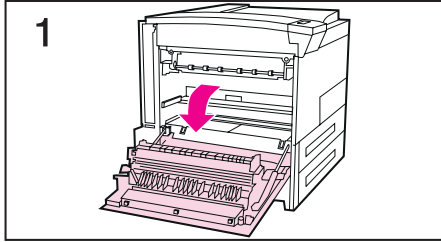

Duplexer

- 1 With the printer turned off and unplugged, open the Diverter door on the left side of the printer.
- 2 Push down the green release lever located at the lower right of the Duplexer and slide it straight out of the printer.

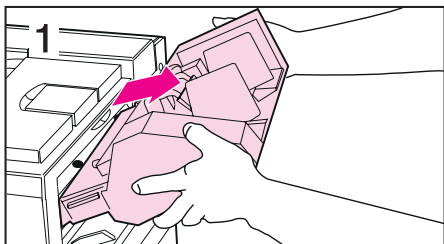

Envelope Feeder

- 1 With the printer turned off and unplugged, slide the Envelope Feeder up and out of the printer.

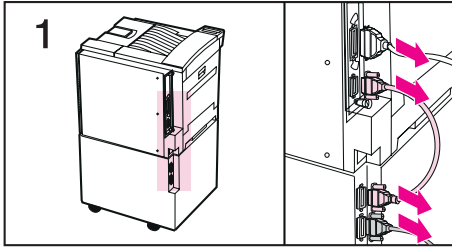

2000-sheet or 2 x 500-sheet Input Tray

- 1 With the printer turned off and the power cable unplugged, disconnect all interface cables from the Formatter Assembly and from Tray 4.

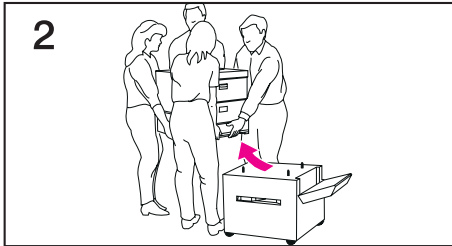

WARNING!

The printer weighs approximately 100 pounds. Use four people to lift it.

- 2 Lift the printer clear of the Tray 4 assembly and place it on a smooth, sturdy surface.

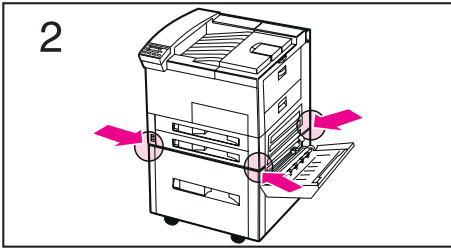
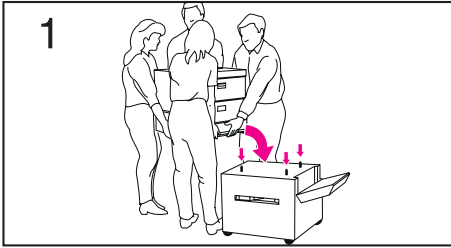

To Reinstall:

- 1 Match the locator pins as illustrated in step 3.
- 2 Make sure that the printer is aligned on all corners

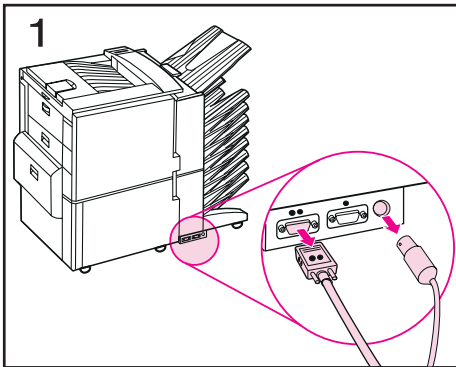

Multibin Mailbox/5-bin Mailbox with Stapler

- 1 With the printer turned off and unplugged, disconnect the power and interface cables from the Multibin Mailbox/Mailbox with Stapler controller PCA.
- 2 Carefully slide the Multibin Mailbox/Mailbox with Stapler away from the printer until the locator tabs and the lower guide rail are clear.

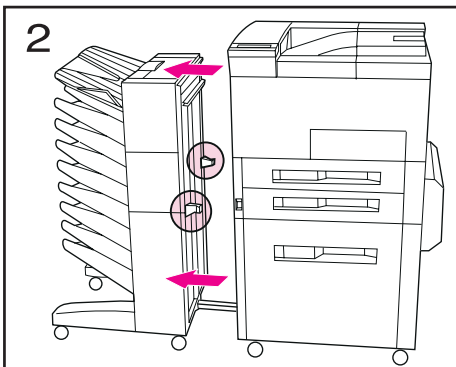

To Reinstall:

- 1 Make sure the lower guide rail and the locator tabs are aligned and the dot pattern on the PCA connector and cable connector match.
- 2 Make sure that the Interlock Switch is fully depressed.
- 3 **To connect the power cables for the 5-bin Mailbox with Stapler only:**

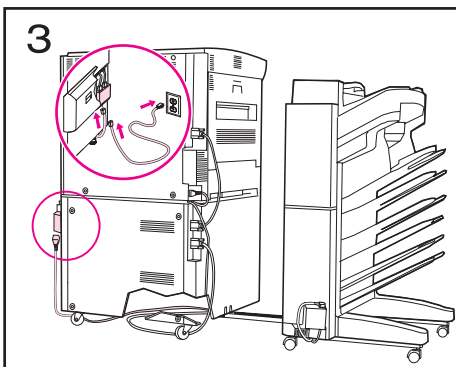

Attach and secure the interface cable to the lower connector on the input tray.

Route the mailbox's power cord beneath the printer to the transfer-door side of the printer and connect it to the bottom of the powerbox.

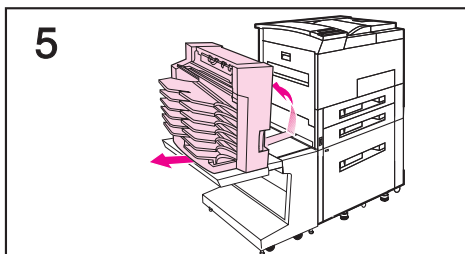
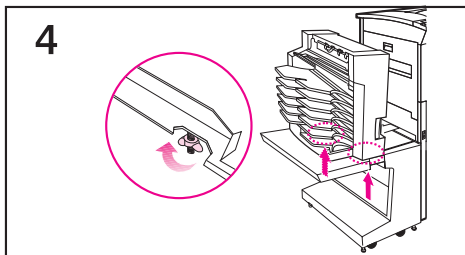
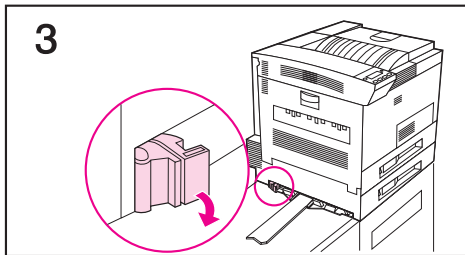
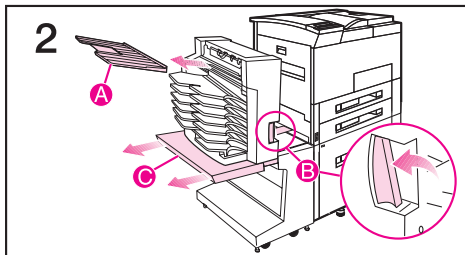
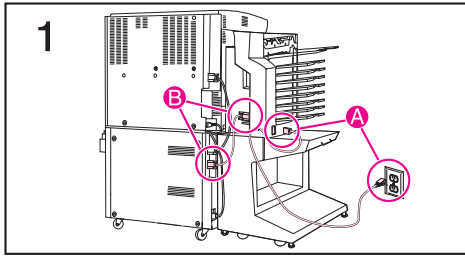

7-bin Tabletop Mailbox

- 1 With the printer turned off and unplugged, disconnect the interface cable from the top (A) and bottom (B) connectors.
- 2 Remove the left output bin (A) from the top slot of the mailbox. Depress the release bar on the front of the mailbox (B). Pull the mailbox away from the printer until the tray is fully extended (C).
- 3 Place your thumb on the blue locking mechanism and pull it away from the printer to release the alignment guide.
- 4 Remove the wingnuts from the studs beneath the tray extension on the stand.
- 5 Slide the mailbox away from the printer. Raise the alignment bar and tape it in place before moving the mailbox.

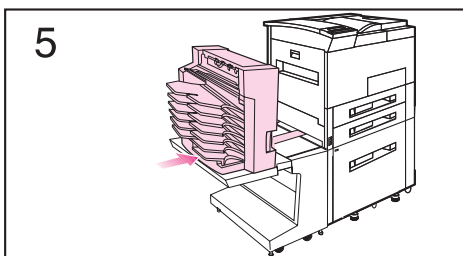
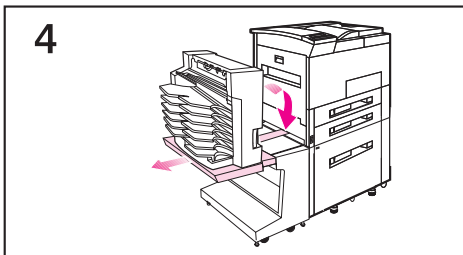
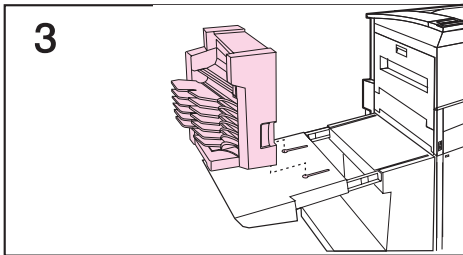
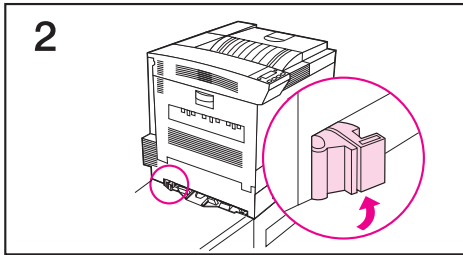
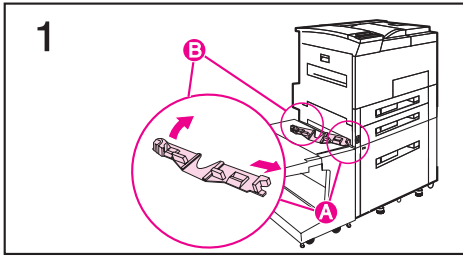

To Reinstall:

- 1 Install the alignment guide under the printer securing the right side first (A). Push the left side of the alignment guide under the printer (B).
- 2 Push the blue locking mechanism on the left side of the alignment guide until it clicks two times and locks in place.
- 3 Place the mailbox onto the stand by aligning the threaded studs on the connector plate with the two holes on the top of the stand.
- 4 With the tray on the stand fully extended, lower the alignment bar onto the alignment guide.
- 5 Slide the mailbox toward the printer.

Note

Use your thumbs to do this and keep the tray on the stand fully extended.

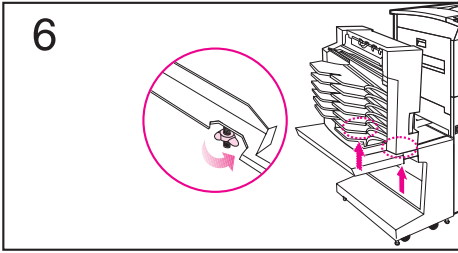

6 Secure the mailbox to the stand by tightening the wingnuts onto the studs beneath the tray extension on the stand.

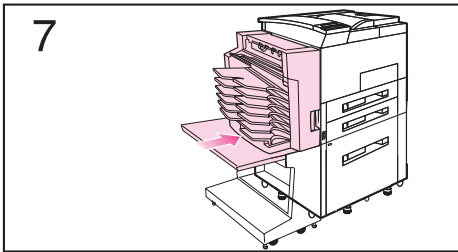

7 Push the mailbox toward the printer until it snaps in place.

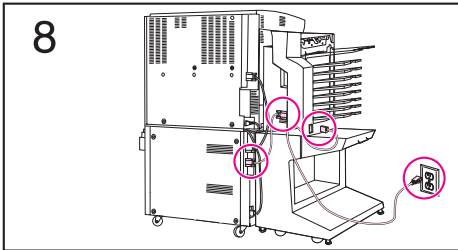

8 Connect the cables and plug the power cord into the mailbox and an AC power outlet.

Hardware Table

Note

The screws listed in table 6-1 are also listed in Chapter 8 with their respective assemblies.

Table 6-1. Hardware Table



Example	Reference	Description	Part Number	Usage
	CH101 and CH102	Screw, w/washer, M3x8	XA9-0872-000CN	General, Metal to metal
	CH103	Screw, M4X8	XB6-7400-807CN	Main Motor
	CH104	Screw, CT, M3X3	XB5-6303-007CN	Fan 1, Fan 2
	CH105	Screw, w/washer, M3X20	XA9-0817-000CN	Laser/Scanner
	CH106	Screw, tapping, truss head, M3X8	XB4-7401-809CN	HVPS, DC Controller
	CH107	Screw, tapping, pan head, M4X10	XB4-7401-009CN	Diverter Assembly, Face-up Solenoid Assembly
	CH108	Screw, TP, M4X6	XB6-7400-606CN	2000-sheet Input Tray, general use

Table 6-1. Hardware Table

Example	Reference	Description	Part Number	Usage
	CH109	Screw, TP, M4X6	XB6-7400-607CN	2000-sheet Input Tray, right cover
	CH110	Screw, TP, M3X6	XB6-7300-607CN	2000-sheet Input Tray, Transfer Assembly
	CH111	Screw, Torx T20, M4X12	Included in Hardware Kit C3764-67901	Multibin Mailbox/ 5-bin Mailbox with Stapler, Elevator Head
	CH112	Screw, Torx T20, M4X10	Included in Hardware Kit C3764-67901	Multibin Mailbox/ 5-bin Mailbox with Stapler, general use
	CH113	Screw, tapping, Torx T20, M4X10	Included in Hardware Kit C3764-67901	Multibin Mailbox/ 5-bin Mailbox with Stapler, Controller PCA

Control Panel

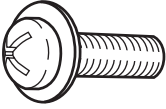
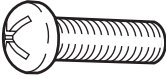
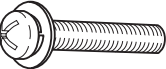

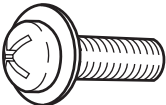
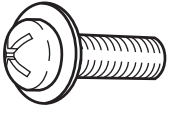
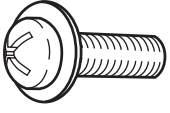
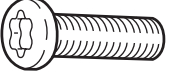
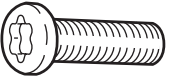
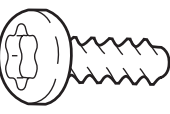
Figure 6-3 **Control Panel**

- 1 While pushing in on the center area (figure 6-3, callout), lift up on the forward edge of the control panel to release the plastic retaining tab.
- 2 Remove the cable from the retainer, and unplug the control panel connector.

To Reinstall:

Plug in the cable, replace the cable in its retainer, insert the rear edge of the control panel under the top cover lip, and press down on the forward edge to snap it into place.

Covers

There are five cover assemblies in this printer:

- AC Access Cover, located at the left rear of the printer.
- Back Cover, provides access to the High Voltage Power Supply, DC Controller, Low Voltage Power Supply, and Main Motor.
- Front Cover, including front access door.
- Left Lower Cover, located below the Diverter Access Door.
- Top Cover, provides access to the Face-down Delivery Unit and Laser/Scanner Assembly.

AC Access Cover

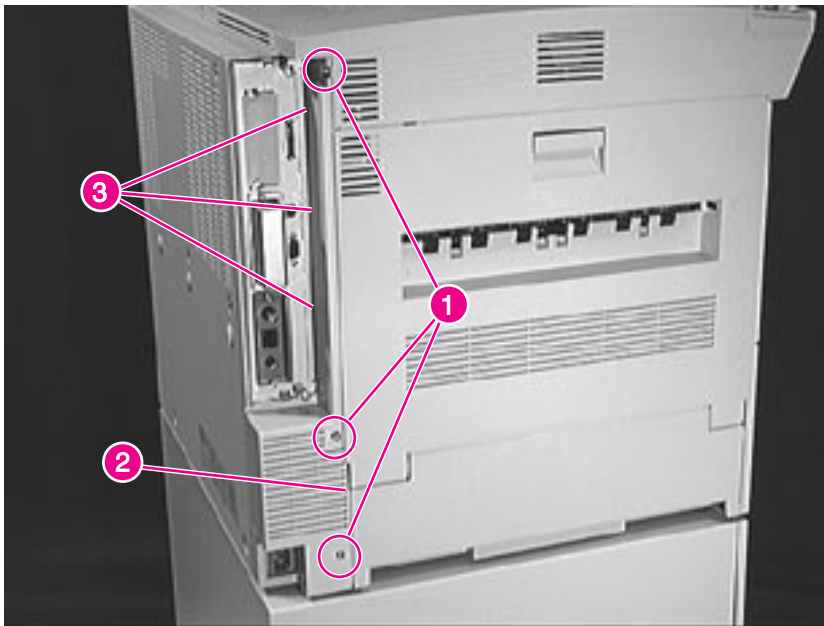

Figure 6-4 AC Access Cover

- 1 Remove the Formatter PCA.
- 2 Remove 3 screws (figure 6-4, callout 1).

To Reinstall:

- 1** Insert the panel edge (figure 6-4, callout 2) inside the back cover (if installed).
- 2** Be sure to insert the three alignment tabs (figure 6-4, callout 3) into their slots before replacing the screws.

Back Cover

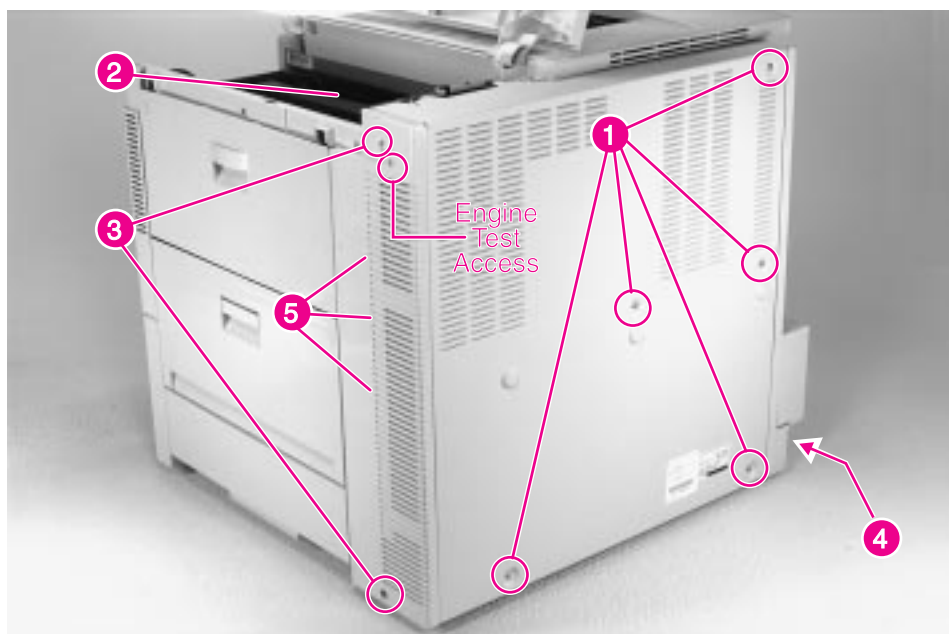

Figure 6-5 Back Cover

Note

Remove the metal back cover and the plastic panel at the right rear as a single unit. The square opening at the upper rear corner on the right-side plastic panel is the engine test access.

- 1 Remove 5 screws (figure 6-5, callout 1).
- 2 Open the top cover door, and remove 1 screw (figure 6-5, callout 2)
- 3 Open the 2000-sheet Input Tray transfer door (if installed), Tray 1, and the Right Lower Door Assembly.
- 4 Remove 2 screws (figure 6-5, callout 3) from the plastic panel to the left of the metal back cover.
- 5 Carefully release the cover around the AC input connector (figure 6-5, callout 4) at the lower right of the back cover, and slide the right side of the cover slightly forward.
- 6 Carefully release the retaining tabs (figure 6-5, callout 5) on the plastic panel to the left of the metal back cover by gently pulling the cover to the left while moving both pieces away from the printer chassis.

Front Cover

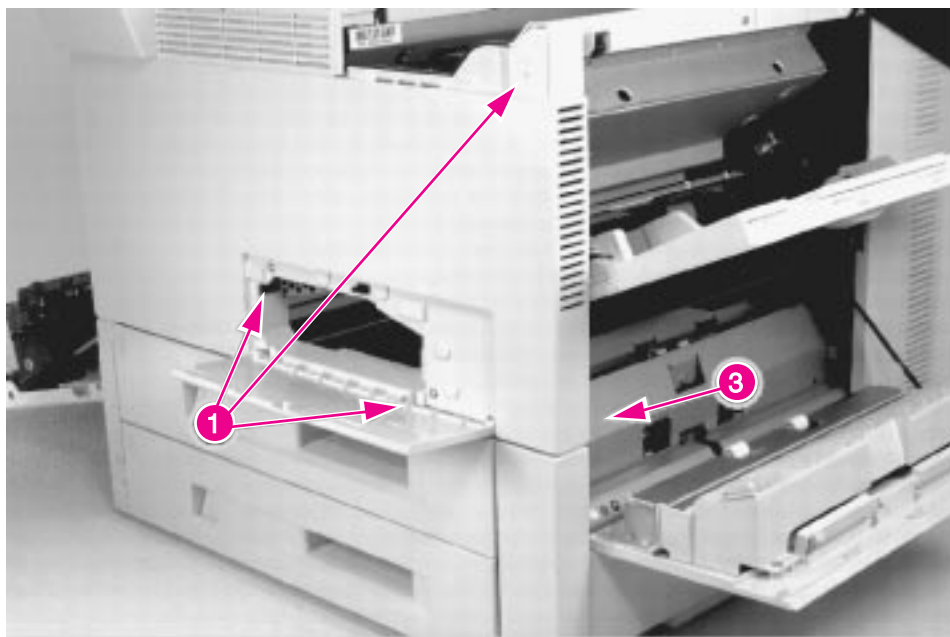

Figure 6-6 Front Cover (1 of 2)

- 1 Open all access doors and remove the Duplexer if installed.
- 2 Open the front access door, and remove 3 screws (figure 6-6, callout 1).

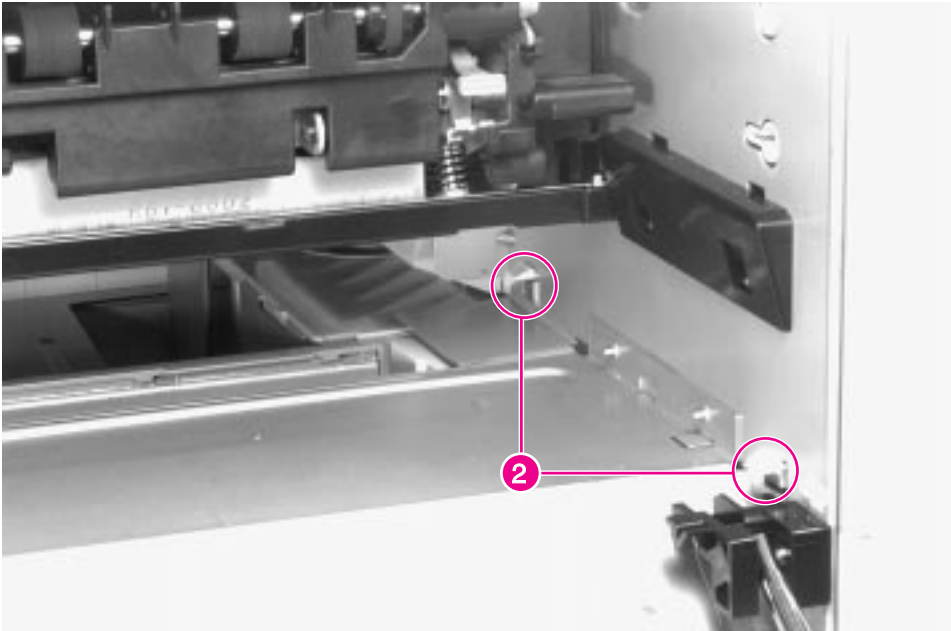

Figure 6-7 Front Cover (2 of 2)

- 3 Open the Diverter Access Door and release the two plastic retaining tabs inside the Duplexer cavity (figure 6-7, callout 2).

CAUTION

Be careful; the plastic upper retaining tabs will break off if the cover is tilted too far out.

- 4 Carefully pull the bottom of the cover away from the chassis while moving it to the right to release the retaining tab (figure 6-6, callout 3).
- 5 Carefully tilt the bottom edge of the cover away from the chassis to release the upper retaining tabs.

Left Lower Cover

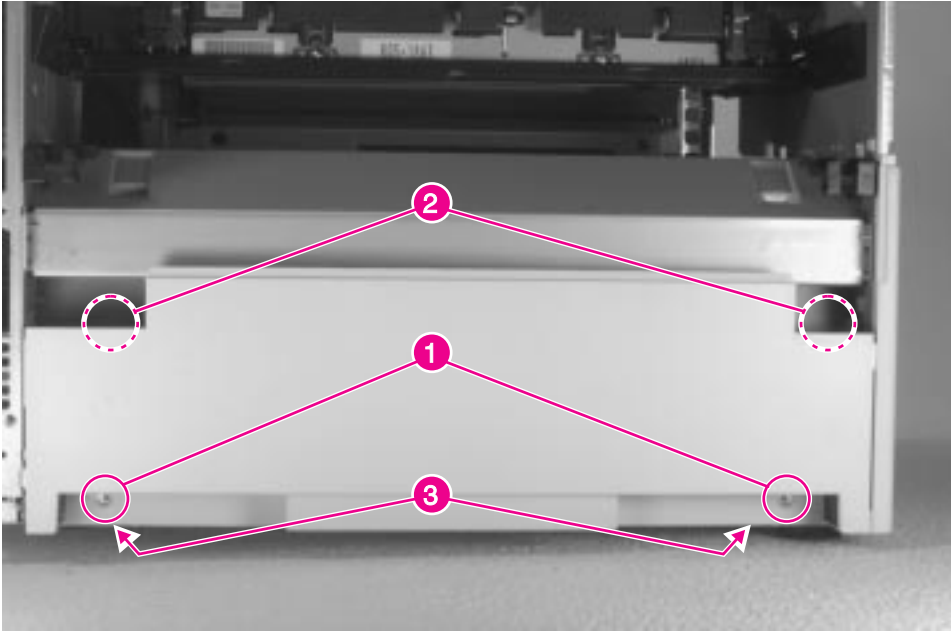

Figure 6-8 Left Lower Cover

CAUTION

Be careful not to damage the plastic guides on the inside of the lower left cover. They are part of the Duplexer paper path.

- 1 Remove the Diverter Assembly access door (see figure 6-14).
- 2 Remove 2 screws (figure 6-8, callout 1).
- 3 Press down firmly on the top cover outer ends to release the retaining tabs on the inside of the cover (figure 6-8, callout 2) and the retaining tabs at the lower edge of the cover (figure 6-8, callout 3).
- 4 Pull the cover away from the chassis, left side first.

To Reinstall:

- 1 Tuck the right side of the cover behind the plastic edge piece first.
- 2 Slide the cover toward the chassis and insert the two retaining tabs into position. Lift up to snap the cover into place.

Top Cover

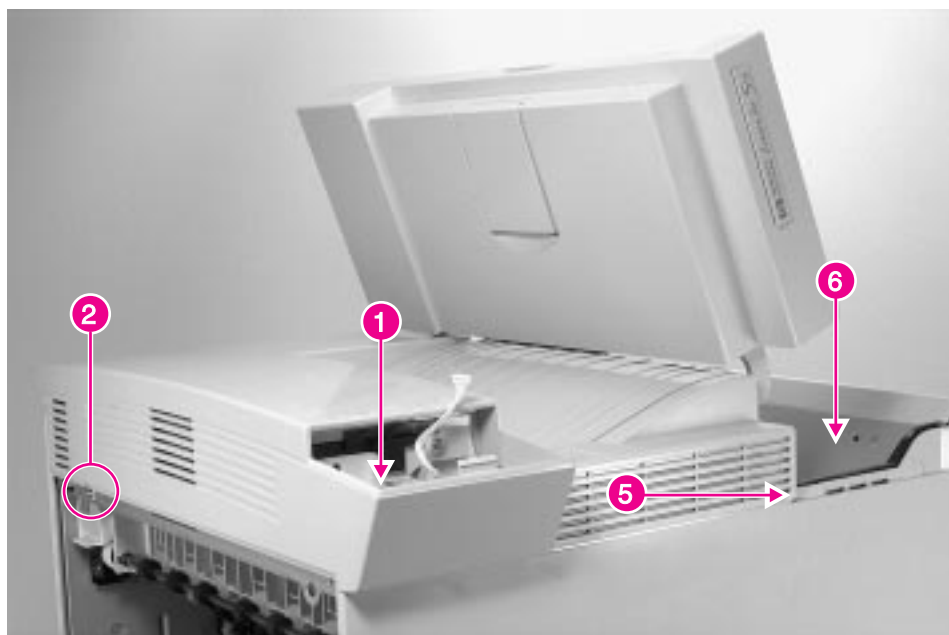

Figure 6-9 Top Cover (1 of 2)

- 1 Remove the Control Panel (see figure 6-3 on page 159), and remove 1 screw (figure 6-9, callout 1).
- 2 Open the Diverter Assembly access door, and remove 1 screw (figure 6-9, callout 2).

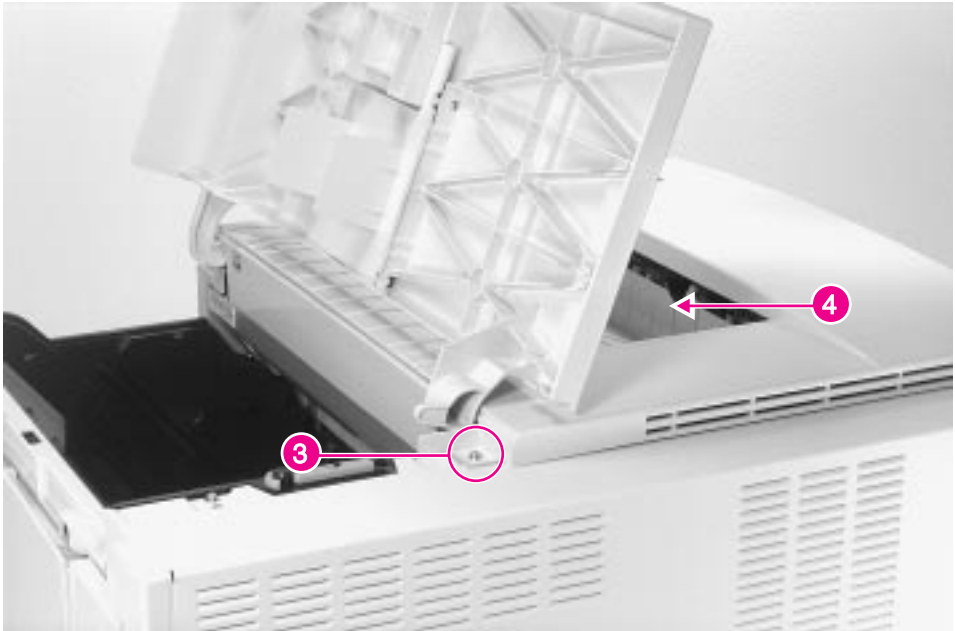

Figure 6-10 Top Cover (2 of 2)

- 3 Open the top cover door, and remove 1 screw (figure 6-10, callout 3).

CAUTION

Be careful not to damage the Standard Output Bin Full sensor flag (figure 6-10, callout 4) when removing the top cover.

- 4 Lift (and hold) the top cover door up, and carefully pull out on the cover to release the retaining tab (figure 6-9, callout 5).
- 5 Hold the Standard Output Bin (figure 6-9, callout 6) down while carefully and slowly lifting the top cover straight up until it clears the Standard Output Bin Full sensor flag and the Delivery Unit.

To Reinstall:

CAUTION

Be careful not to damage the Standard Output Bin Full sensor flag (figure 6-10, callout 4) when replacing the top cover.

- 1 Hold the top cover door up and the Standard Output Bin (figure 6-9, callout 6) down while lowering the cover into position.
- 2 See figure 6-10, callout 4. Slide the Standard Output Bin under the Standard Output Bin Full sensor flag, and make sure that the cam (figure 6-10, callout 4) at the rear of the top cover door is properly positioned while lowering the top cover into place.
- 3 Make sure that the top cover is seated properly and that the retaining tabs are in place before replacing the screws.

Delivery Unit (for Standard Output Bin)

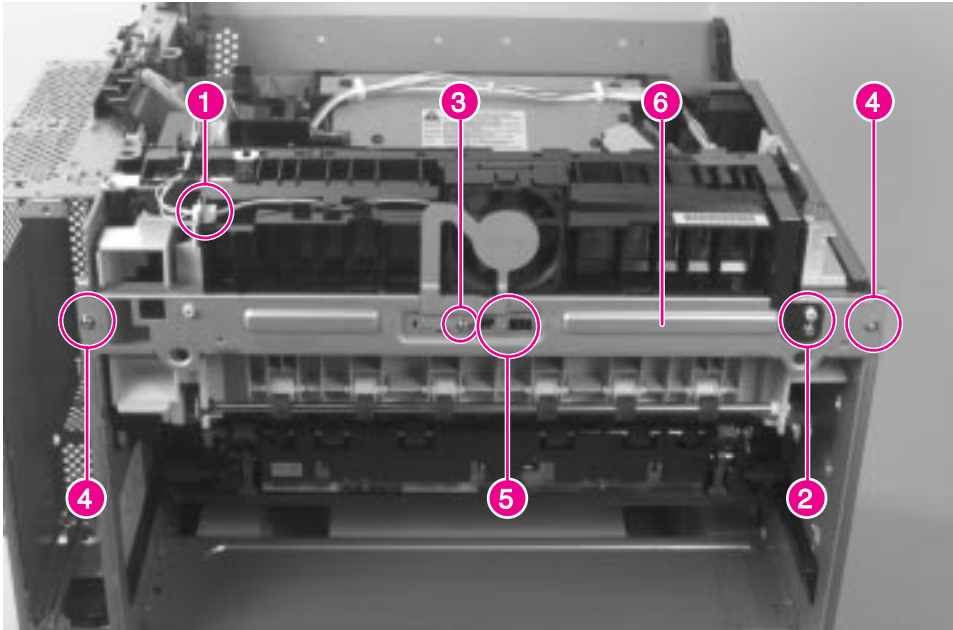

Figure 6-11 Delivery Unit (1 of 2)

- 1 Remove the following components:
 - Formatter Assembly (see figure 6-25 on page 186)
 - AC Access Cover (see figure 6-4 on page 160)
 - Top Cover (see figure 6-9 on page 166)
 - Front Cover (see figure 6-6 on page 163)
- 2 Unplug and re-route the fan cable out of the way (figure 6-11, callout 1).
- 3 Remove 1 screw (figure 6-11, callout 2) to loosen the grounding strip.
- 4 Remove 1 screw (figure 6-11, callout 3), and remove the metal fan shield.
- 5 Open the Diverter Assembly access door, remove 2 screws (figure 6-11, callout 4), release the plastic retaining tabs (figure 6-11, callout 5), and remove the metal mounting bracket (figure 6-11, callout 6).

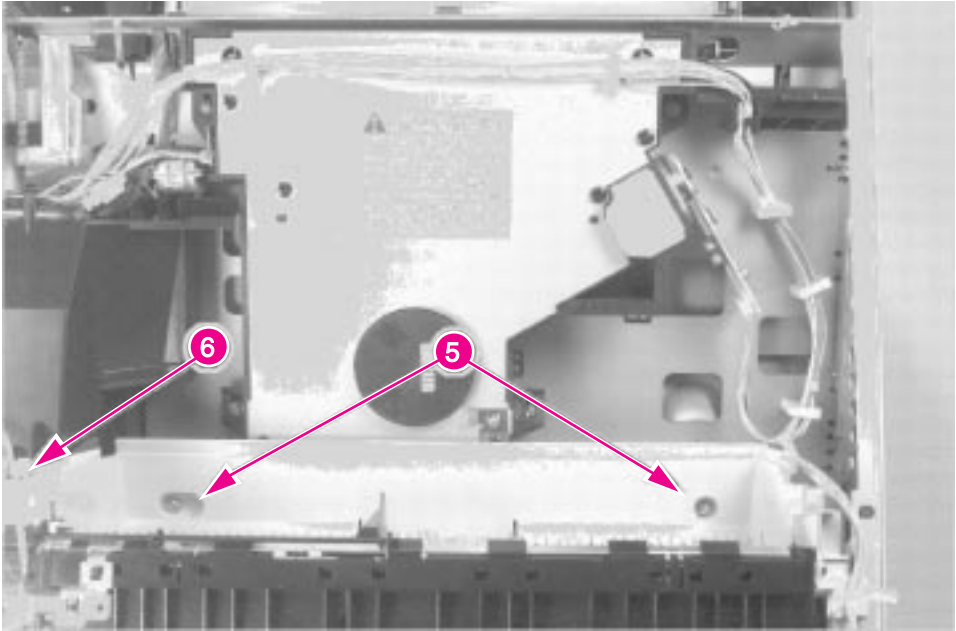

Figure 6-12 Delivery Unit (2 of 2)

- 6 Remove 2 screws (figure 6-12, callout 5) and 1 screw (figure 6-12, callout 6).

CAUTION

Be careful not to damage the plastic sensor flags and gears on the left end of the Delivery Unit.

- 7 Lift the left end of the Delivery Unit approximately 1/8 inch to clear the alignment pin, and carefully rock it forward and backward while sliding it out of the chassis.

To Reinstall:

CAUTION

Be careful not to damage the plastic sensor flags and gears on the left end of the Delivery Unit.

- 1 Place the plastic edge on the right end of the Delivery Unit into the chassis. Make sure that the plastic support tab on the right end of the Delivery Unit slides on top of the chassis.
- 2 Make sure that the plastic sensor flags and gears on the left end of the Delivery Unit are properly positioned (not jammed).
- 3 Replace the metal mounting bracket (figure 6-11, callout 6) before replacing the Delivery Unit screws. Make sure that the plastic clips (figure 6-11, callout 5) are snapped into place before tightening the mounting screws (figure 6-11, callout 4).

Diverter Assembly

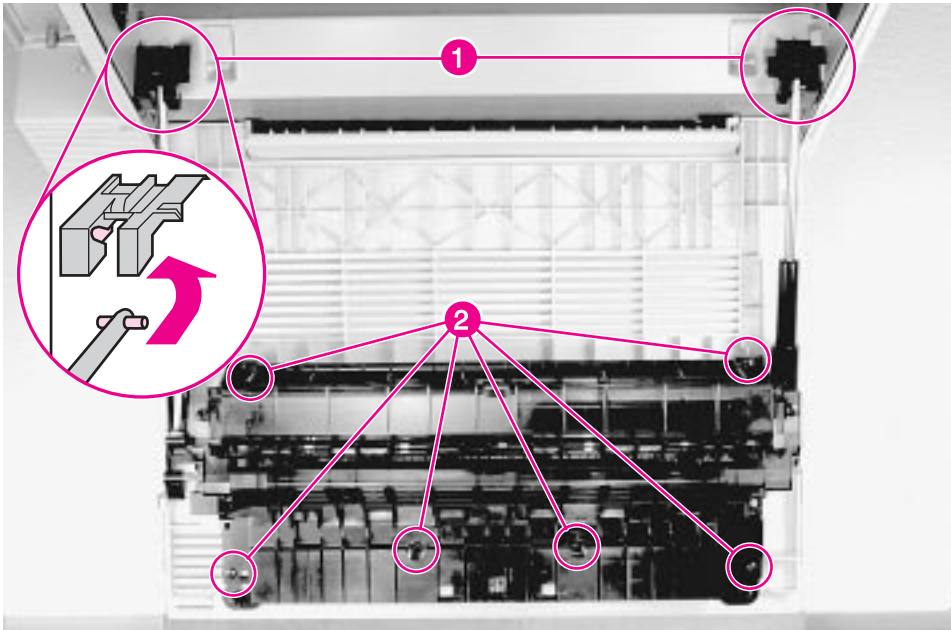

Figure 6-13 Diverter Assembly

CAUTION

Support the Diverter Assembly access door during this procedure to prevent damage to the plastic hinge pins.

- 1 Open the Diverter Assembly access door and release the support struts (figure 6-13, callout 1) by sliding the strut ends forward and downward.
- 2 Remove 6 self-tapping screws (figure 6-13, callout 2).

Note

The access door support struts will fall free when the Diverter Assembly is lifted away from the access door.

- 3 Lift the Diverter Assembly up and away from the access door.

Door Assembly, Diverter

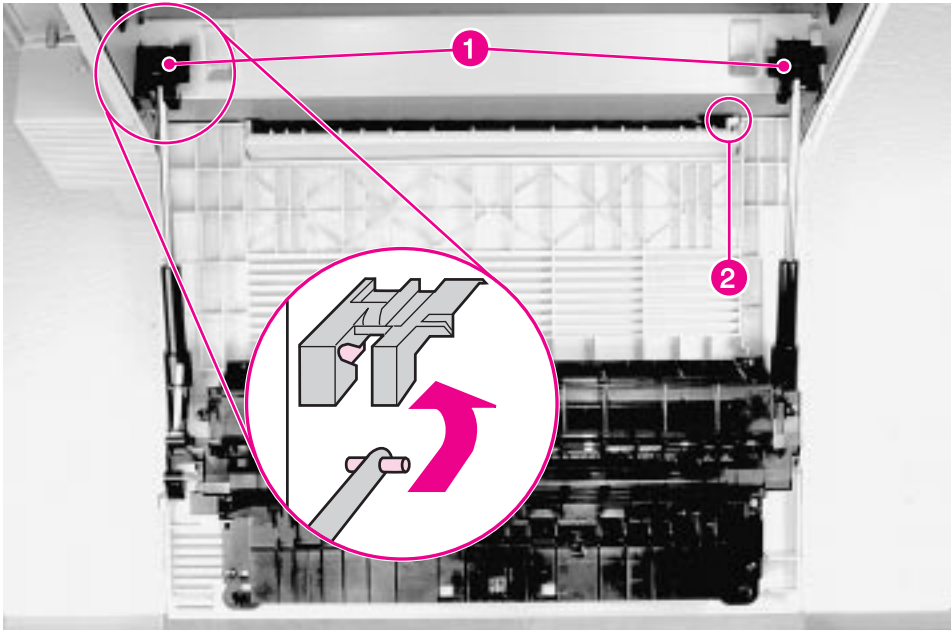

Figure 6-14 Diverter Door Assembly

- 1 Open the Diverter access door, and release the support struts (figure 6-14, callout 1) by sliding the strut ends forward and downward.
- 2 Rotate the door up to align the flat sides of the right hinge pin with the retaining slot (figure 6-14, callout 2), and lift upwards to release it from the retaining slot.
- 3 Continue lifting up on the right side of the door while pushing it to the left to rotate the left hinge pin out of its locating cavity.

To Reinstall:

- 1 Insert the left side of the door into position first, and then rotate the right side down to snap the hinge pins into position.
- 2 Reconnect the support struts to the chassis.

Door Assembly, Right Lower

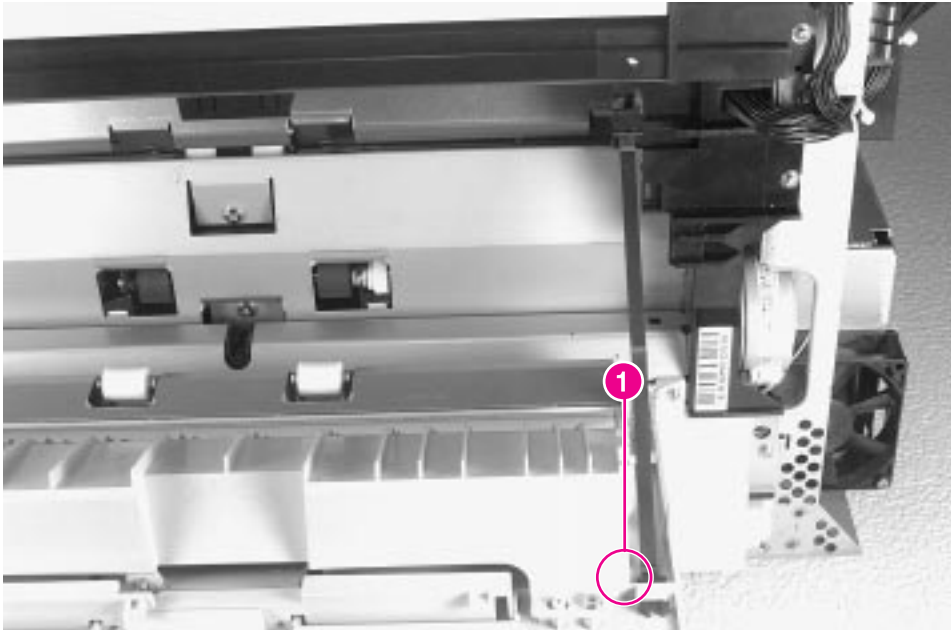

Figure 6-15 Right Lower Door Assembly (1 of 3)

- 1 Remove the back cover assembly (see figure 6-5).
- 2 Remove Tray 2 and Tray 3.
- 3 Open the Right Lower Door, and release the lower end of the support strap (figure 6-15, callout 1).

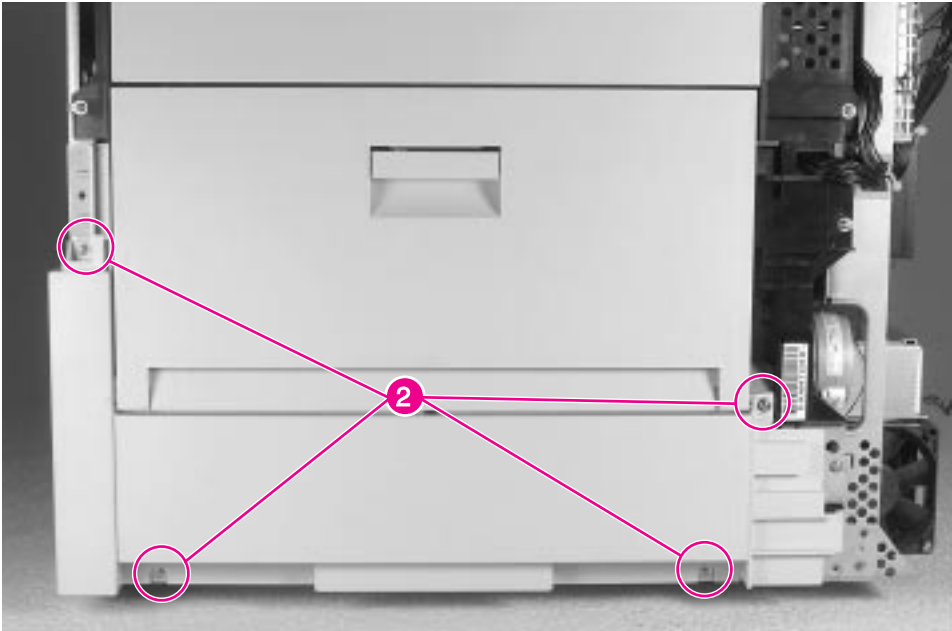

Figure 6-16 Right Lower Door Assembly (2 of 3)

- 4 Remove 4 screws (figure 6-16, callout 2).

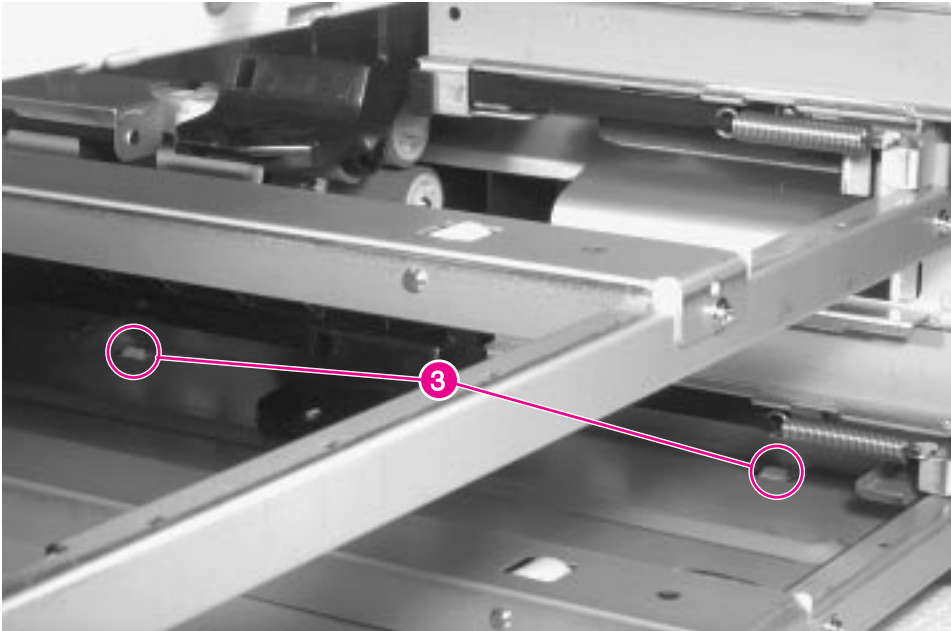

Figure 6-17 Right Lower Door Assembly (3 of 3)

- 5 Release two retainer tabs from the inside of the Tray 3 cavity (figure 6-17, callout 3).
- 6 Slide the door assembly away from the printer chassis.

Fan 1, Exhaust (Laser/Scanner) and Housing

Fan Housing

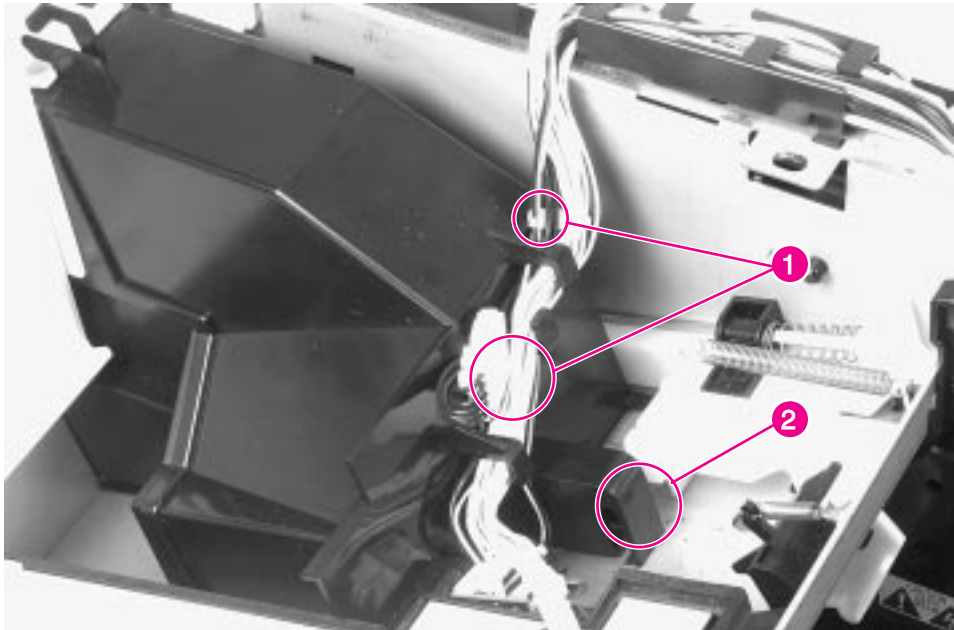

Figure 6-18 Fan 1, Laser/Scanner (1 of 2)

- 1 Remove the toner cartridge.
- 2 Remove the top cover (see figure 6-9 on page 166).
- 3 Remove and re-route the cables away from fan housing (figure 6-18, callout 1).
- 4 Release the housing retainer clip located inside the toner cartridge cavity (figure 6-18, callout 2), and lift the housing up and out of the chassis.

Fan Motor

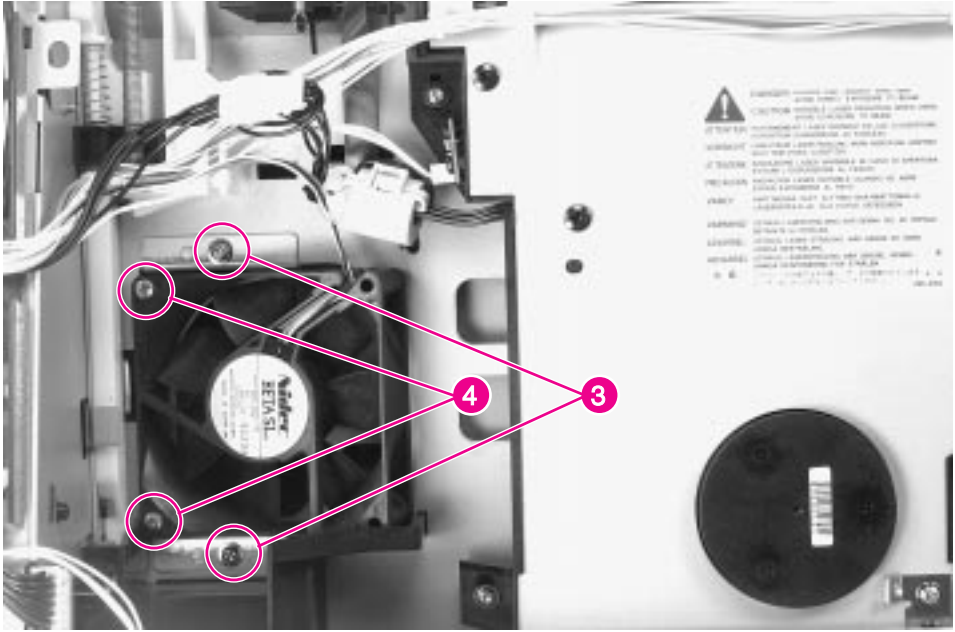

Figure 6-19 Fan 1, Laser/Scanner (2 of 2)

- 1 Unplug the fan cable from the DC Controller PCA.
- 2 Remove 2 screws (figure 6-19, callout 3), and lift the fan and bracket assembly out of the chassis.
- 3 Remove 2 screws (figure 6-19, callout 4) to separate the fan motor from the bracket.

Fan 2, Exhaust (LVPS)

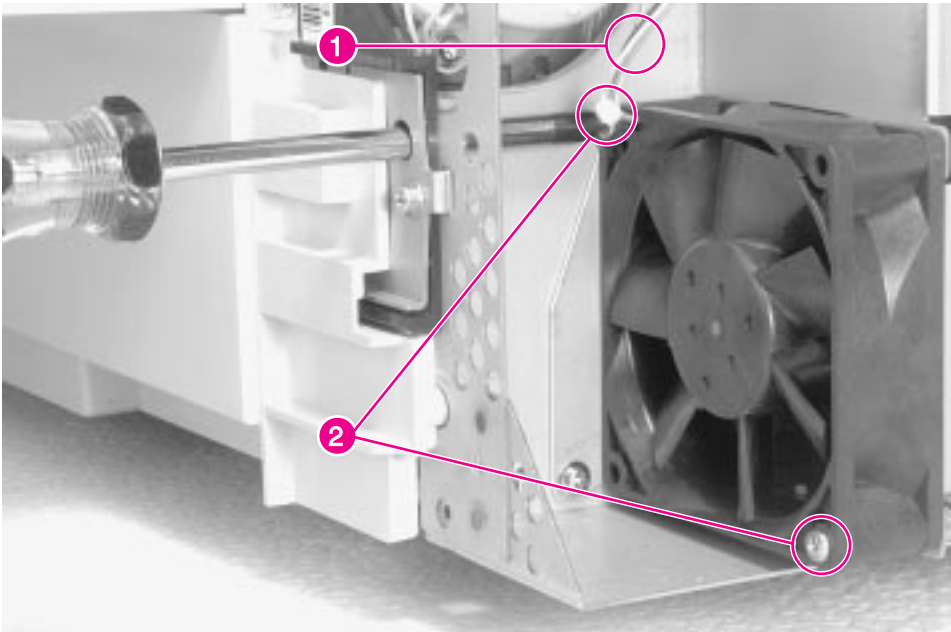

Figure 6-20 Fan 2, LVPS

- 1 Remove the back cover (see figure 6-5 on page 162).
- 2 Remove the fan cable from the DC Controller PCA (figure 6-20, callout 1).
- 3 Remove 2 screws (figure 6-20, callout 2).

Fan 3, Intake (Formatter) and Housing

Fan Motor

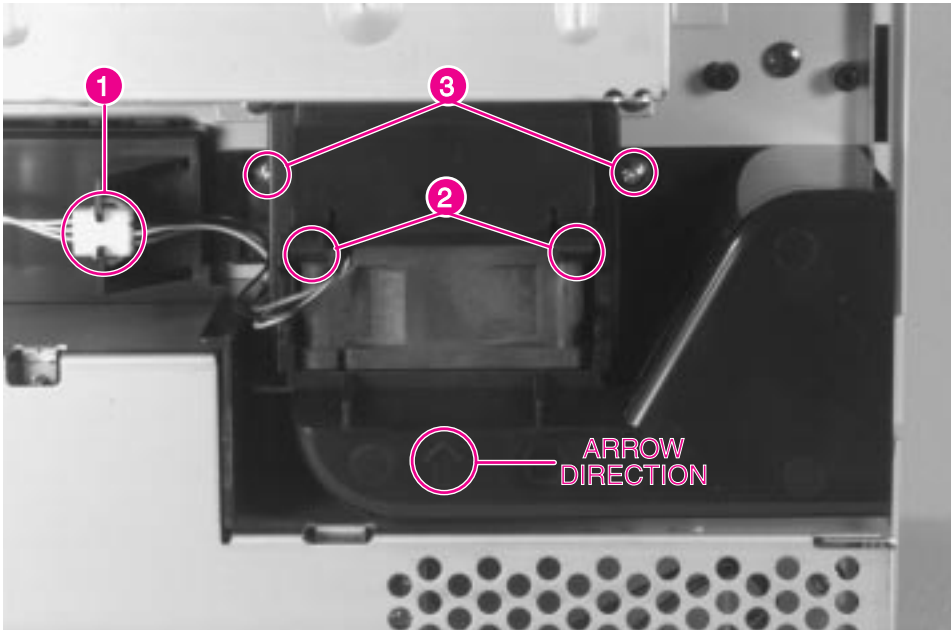

Figure 6-21 Fan 3, Formatter

Note

The fan motor (FM3) can be removed without removing the housing assembly.

- 1 Remove the back cover (see figure 6-5 on page 162).
- 2 Unplug the fan connector (figure 6-21, callout 1).

CAUTION

Do not bend the fan retainer clips upward. Release them by pinching.

- 3 Release the 2 retainer clips (figure 6-21, callout 2), and slide the fan out of the housing assembly.

To Reinstall:

Make sure that the fan cable exits from the upper left corner.

Fan Housing (See Fan 2)

- 4 Remove the back cover (see figure 6-5 on page 162).
- 5 Remove 2 screws (figure 6-21, callout 3).

Fan 4, Exhaust (Delivery Unit)

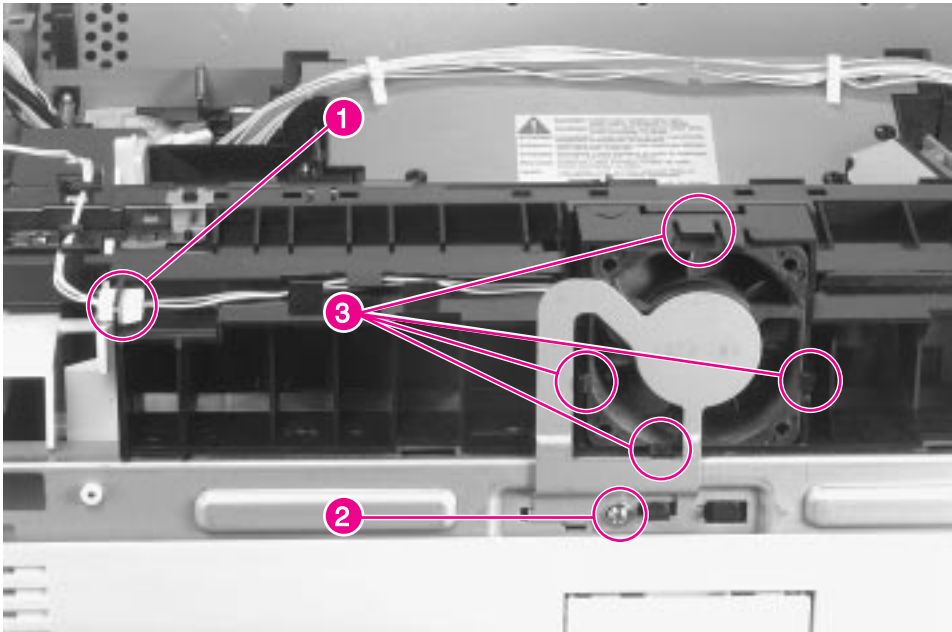

Figure 6-22 Fan 4, Delivery Unit

- 1 Remove the top cover (see figure 6-9).
- 2 Unplug the fan cable (figure 6-22, callout 1).
- 3 Remove 1 screw (figure 6-22, callout 2), and remove the metal fan shield.
- 4 Release 4 retainer clips (figure 6-22, callout 3), and slide the fan forward out of the Delivery Unit Assembly.

Feeder Assembly

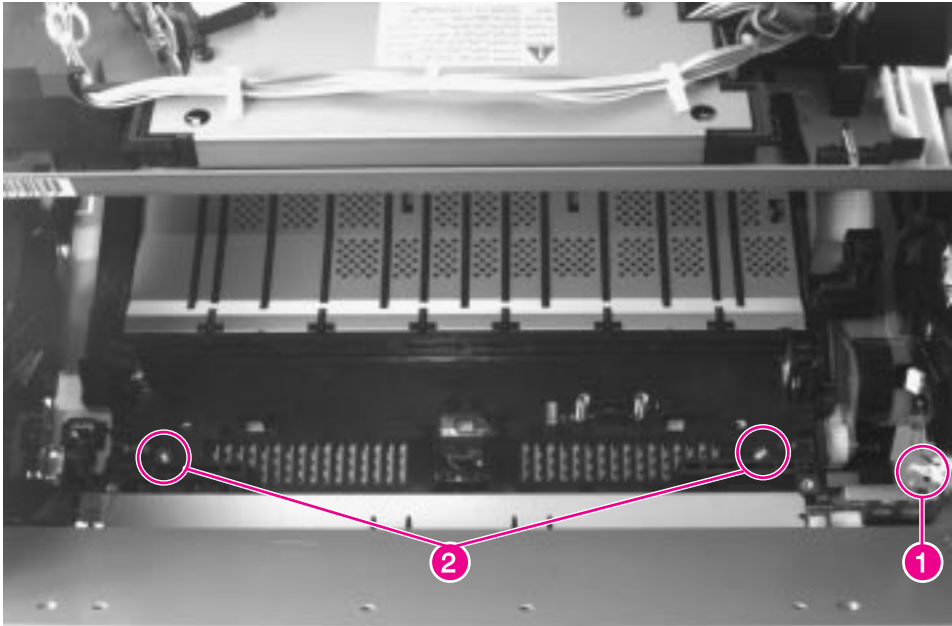

Figure 6-23 Feeder Assembly (1 of 2)

- 1 Open the left access door and remove the Duplexer (if installed).
- 2 Remove the Fusing Assembly (see figure 6-26 on page 187).
- 3 Open the Top Cover and remove the Toner Cartridge.
- 4 Remove the Transfer Roller Assembly (see figure 6-52 on page 219).
- 5 Remove the Registration Assembly (see figure 6-43 on page 207).
- 6 Unplug the sensor cable at the right side of the Feeder Assembly (figure 6-23, callout 1).
- 7 Remove 2 screws at the front of the Feeder Assembly (figure 6-23, callout 2).



Figure 6-24 Feeder Assembly (2 of 2)

- 8 Remove 1 screw at the back of the Feeder Assembly (figure 6-24).

Note

Removing the High Voltage Power Supply is recommended to ease the removal of the Feeder Assembly, primarily because of the contact points.

- 9 Release 4 plastic retaining tabs by moving them in the directions indicated in figure 6-24 while carefully lifting upwards on the Feeder Assembly.
- 10 Remove the Feeder Assembly by lifting it upwards out of the Toner Cartridge cavity.

To Reinstall:

Make sure that the plastic retaining tabs are all properly seated before replacing the screws.

Formatter Assembly

Setting Page Count, Maintenance Count, and Serial Number

The page count, maintenance count, and printer serial numbers are stored in Non-Volatile Memory. `PAGECOUNT` is the total number of images printed by the printer, `MAINTCOUNT` is the page count when the next preventive maintenance should be performed (every 350,000 images), and `S.N.` is the printer serial number (also located on the printer back cover).

If it is necessary to replace the Formatter PCA, these numbers should be set to the current values to accurately reflect the age of the print engine. The procedures for setting these values are listed in table 3-12 on page 76.

Before removing the old Formatter PCA, print a Configuration Page to verify the current values, if possible.

Note

If it is not possible to print a Configuration Page, try to verify the values before replacing the Formatter PCA by following steps 1 through 3, below.

After verifying the page count, maintenance count, and printer serial number from the old Formatter PCA, replace it with the new PCA.

- 1 Enter Service Mode as described in “Service Mode” on page 75.
- 2 When `SERVICE MODE` is displayed, press **MENU** to access the Service Menu.
- 3 Press **ITEMS** to display `PAGECOUNT=`, `MAINTCOUNT=`, and `S.N.=`.
- 4 Enter the appropriate values for each item.
- 5 Press **Go** to exit Service Mode.

Removing and Replacing the Formatter Assembly

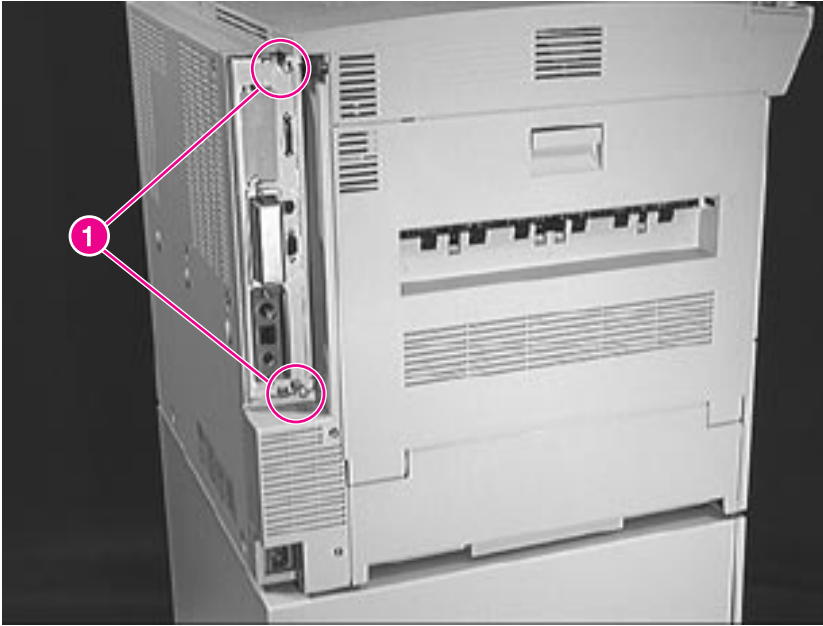

Figure 6-25 **Formatter Assembly**

- 1 If the Formatter is to be replaced, make sure to note the page count.
- 2 Loosen the two captive screws (figure 6-25, callout 1), and slide the Formatter PCA out of the chassis.
- 3 After installation of a replacement Formatter, be sure to re-enter the serial number, page count, and maintenance count. (See table 3-12 on page 76 for more information.)

Fusing Assembly

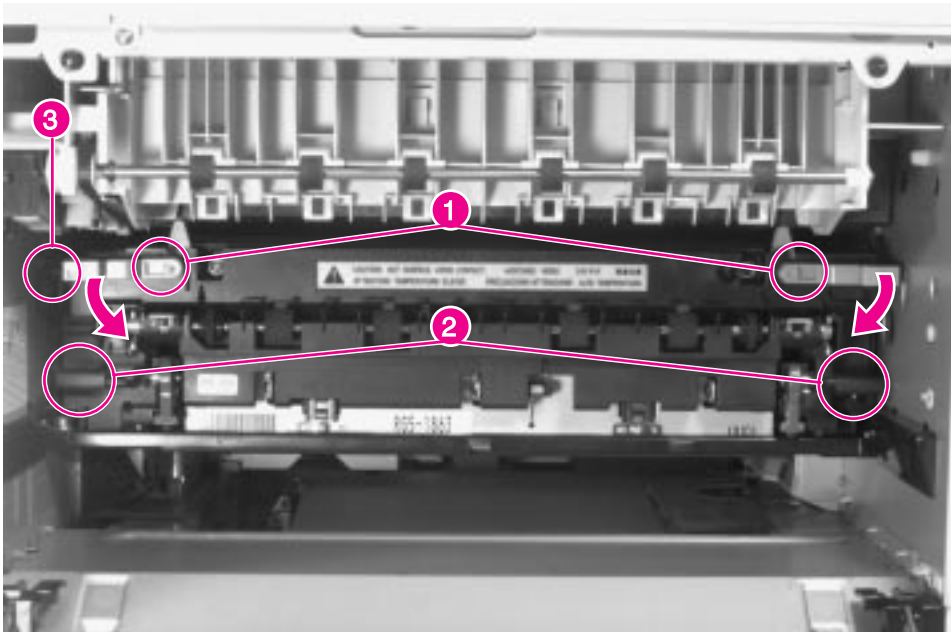

Figure 6-26 Fusing Assembly

- 1 Open the Diverter Assembly access door, and remove the Duplexer if installed.

CAUTION

Use the upper levers to release the Fusing Assembly, NOT the lower levers. The lower levers set the pressure rollers inside the Fusing Assembly for envelope printing (down for single sheets, up for envelopes).

- 2 To release the Fusing Assembly rotate the upper levers down (figure 6-26, callout 1).
- 3 To remove the Fusing Assembly lift up on the finger handles (figure 6-26, callout 2) while pulling outward.

To Reinstall:

- 1** Make sure that the Fuser Output sensor flag (figure 6-26, callout 3) on the upper left corner of the Fusing Assembly rotates freely.
- 2** Make sure that the lower levers are set down for single sheets. If having trouble printing envelopes, move the levers up. Move the levers back down when done.

Laser/Scanner Assembly

CAUTION



The Laser/Scanner diode is extremely sensitive to ESD.

- 1 Remove the toner cartridge.
- 2 Remove the top cover (see figure 6-9).

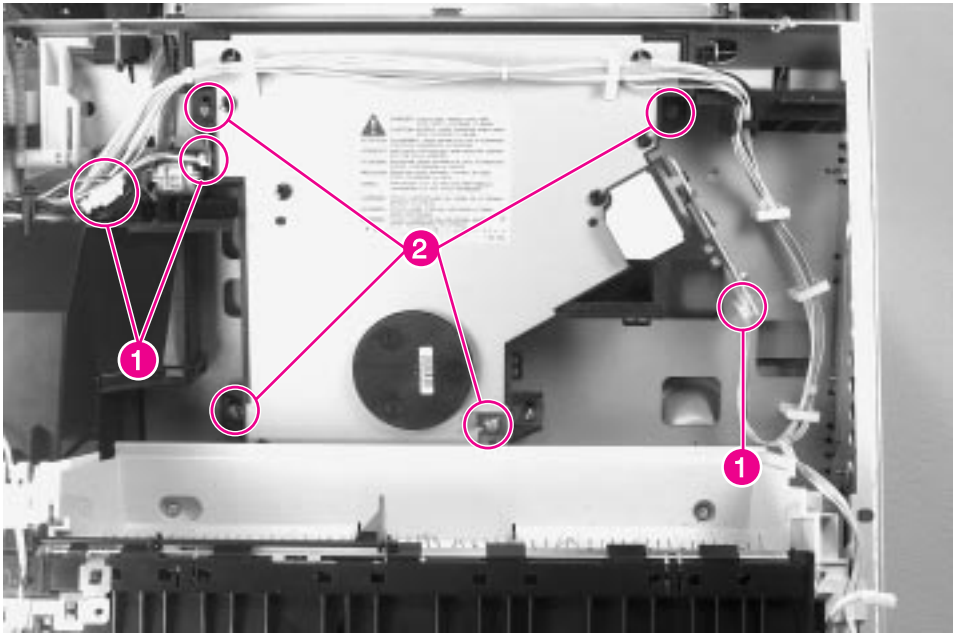

Figure 6-27 Laser/Scanner Assembly

- 3 Unplug three cable connectors (figure 6-27, callout 1).

- 4 Re-route the cable running across the top of the assembly so that it is out of the way.

CAUTION

Do not touch the laser/scanner mirror located under the forward edge of the assembly. Use approved ESD handling procedures when touching the Beam Detect PCA.

- 5 Remove 4 screws (figure 6-27, callout 2).

To Reinstall:

Make sure that the locator pins are properly seated.

Main Gear Assembly

- 1 Remove the following components in the order listed:
 - Toner Cartridge
 - Tray 1
 - Tray 2
 - Transfer Roller Assembly (see figure 6-52 on page 219)
 - Back Cover Assembly (see figure 6-5 on page 162)
 - Tray 1 Assembly (see figure 6-53 on page 221)
 - Right Lower Door Assembly (see figure 6-15 on page 174)
 - Paper Input Unit (PIU) (see figure 6-32 on page 195)
 - High Voltage Power Supply (HVPS) (see figure 6-41 on page 205)
 - Main Motor (see figure 6-31 on page 194)

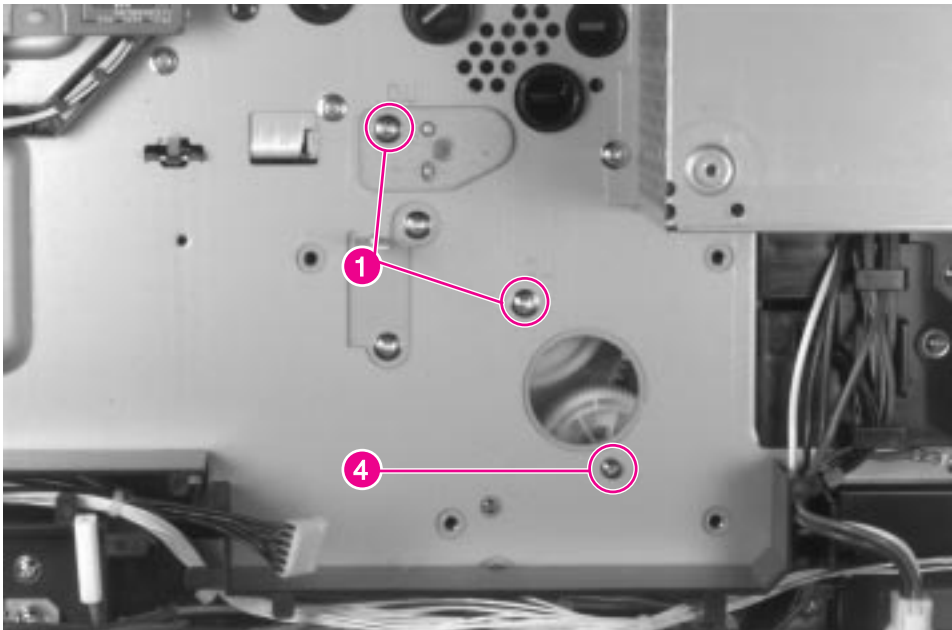

Figure 6-28 Main Gear Assembly (1 of 3)

- 2 Remove 2 screws (figure 6-28 on page 191, callout 1).

CAUTION

Be careful not to damage the plastic gears when removing the Main Gear Assembly.

Note

A slight gentle rocking motion will help free the Main Gear Assembly from the printer.

- 3 From inside of the PIU cavity, carefully tilt the bottom of the Main Gear Assembly away from the chassis and down to free the gear mechanisms.

To Reinstall:

Figure 6-29 Main Gear Assembly (2 of 3)

Note

A slight gentle rocking motion will help install the Main Gear Assembly as it is rotated into place.

- 1 Observe the gear assembly position from inside the toner cartridge cavity (figure 6-29, callout 2).

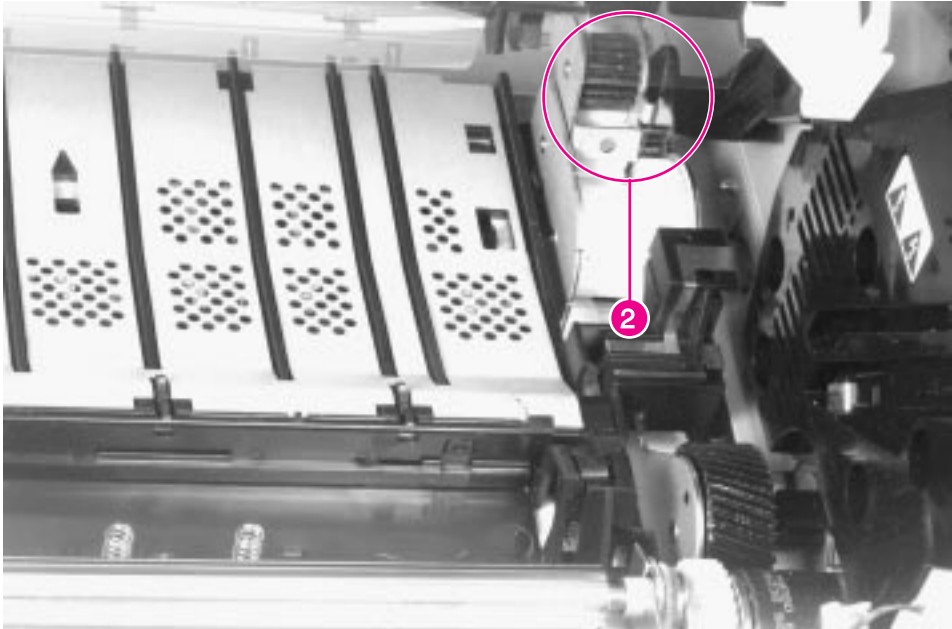
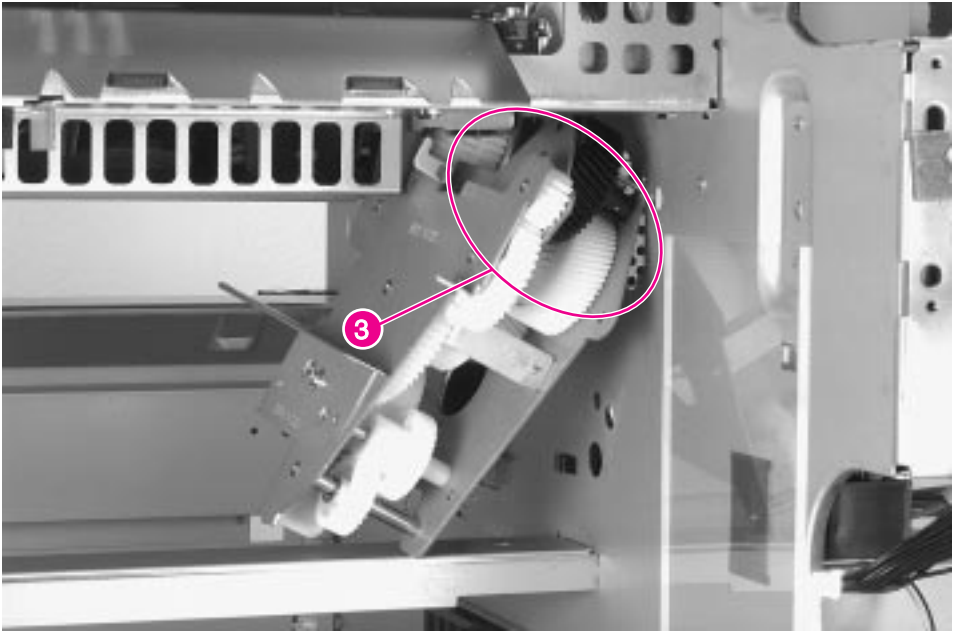

Figure 6-30 Main Gear Assembly (3 of 3)

- 2 Tilt the top of the assembly inward and insert the upper back part of the assembly in place (figure 6-30, callout 3).
- 3 Continue rotating the assembly upwards into place.
- 4 Make sure that the locating pins are properly aligned and that the gear assembly fits tightly against the chassis before replacing the screws (figure 6-28, callout 4).

Main Motor Assembly

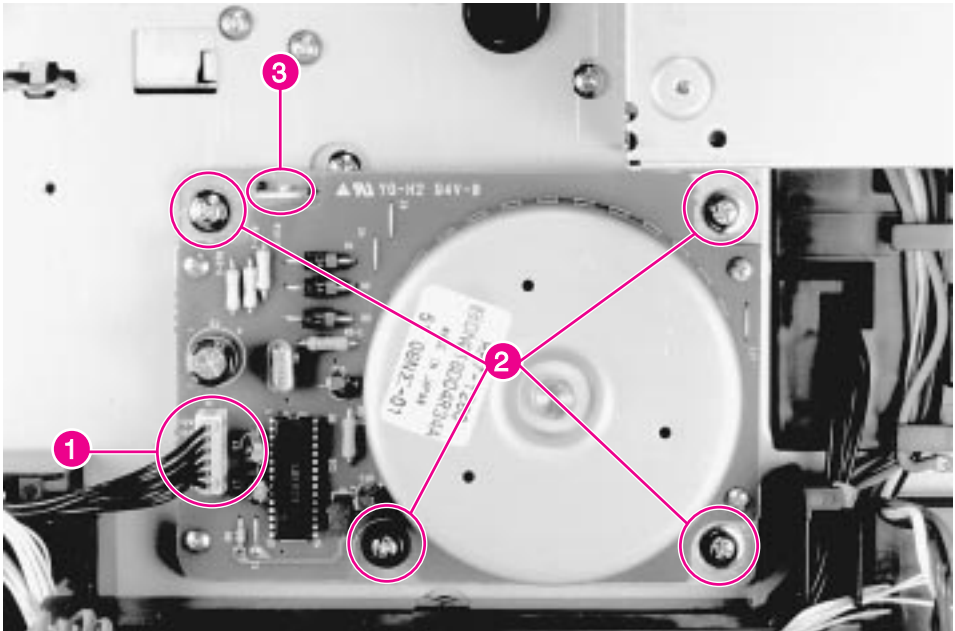

Figure 6-31 Main Motor

- 1 Remove the back cover (see figure 6-5 on page 162).
- 2 Remove the HVPS (see figure 6-41 on page 205).
- 3 Unplug the connector (figure 6-31, callout 1).

CAUTION

Be careful when removing the Main Motor. The steel drive shaft can damage the plastic gears.

- 4 Remove 4 screws (figure 6-31, callout 2).

To Reinstall:

Align the Main Motor to the chassis with the locator tab (figure 6-31, callout 3) and the machined ring around the output shaft.

Paper Input Unit (PIU)

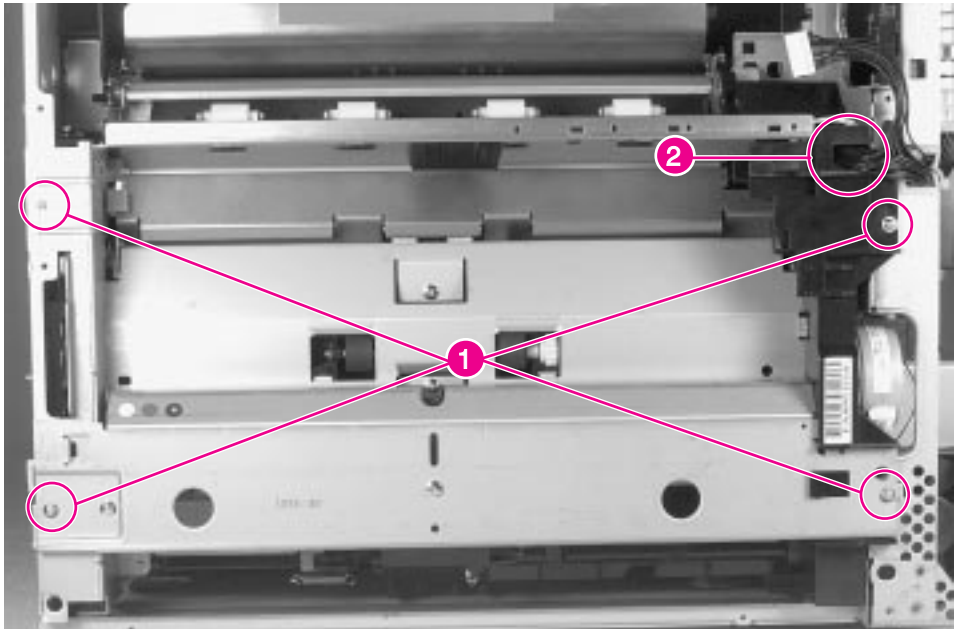

Figure 6-32 Paper Input Unit

CAUTION

Remove both Tray 2 and Tray 3 to prevent damage to the PIU plastic sensor flags.

- 1 Remove Tray 2 and Tray 3.
- 2 Remove the back cover (see figure 6-5 on page 162).
- 3 Remove the Tray 1 Assembly (see figure 6-53 on page 221).
- 4 Remove the Right Lower Door Assembly (see figure 6-15 on page 174).
- 5 Remove 4 screws (figure 6-32, callout 1).
- 6 Slide the assembly out from the chassis approximately 3 inches, and unplug the connector inside the right end (figure 6-32, callout 2).
- 7 Continue sliding the assembly out of the chassis.

To Reinstall:

Make sure that Trays 2 and 3 are removed when reinstalling the Paper Input Unit.

PCA, DC Controller

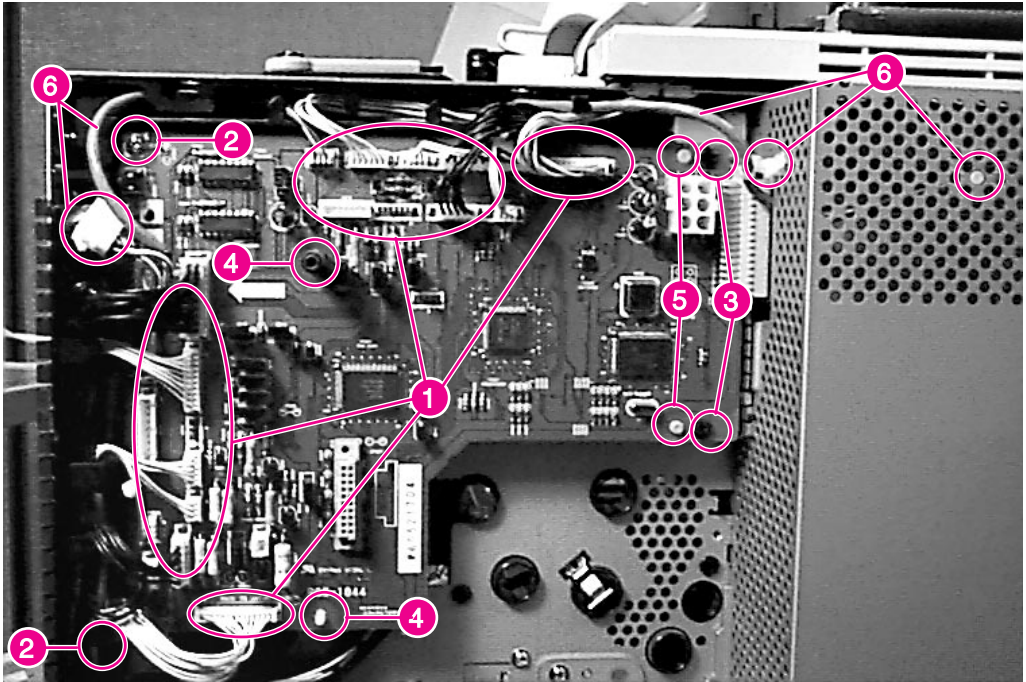

Figure 6-33 DC Controller PCA

- 1 Remove the Formatter Assembly (see figure 6-25 on page 186).
- 2 Remove the back cover (see figure 6-5 on page 162).
- 3 Remove the High Voltage Power Supply (see figure 6-41 on page 205).
- 4 Unplug 18 connectors from the PCA (figure 6-33, callout 1).
- 5 Remove 2 screws (figure 6-33, callout 2) from the left side of the PCA and 2 self-tapping screws (figure 6-33, callout 3) from the right side of the PCA.
- 6 Release two retaining clips (figure 6-33, callout 4) and carefully tip the left side of the PCA outward to clear the Formatter PCA connector from the card cage.

To Reinstall:

Make sure the retaining clip posts (figure 6-33, callout 4) and the two locator pins (figure 6-33, callout 5) are properly aligned.

PCA, Output Paper Sensor

- 1 Remove the following components in the order listed:
 - Toner Cartridge
 - Formatter Assembly (see figure 6-25 on page 186)
 - AC Access Cover (see figure 6-4 on page 160)
 - Top Cover (see figure 6-9 on page 166)
 - Back Cover (see figure 6-5 on page 162)
 - Fan 3 and Housing Assembly (see figure 6-21 on page 180)
 - High Voltage Power Supply (HVPS) (see figure 6-41 on page 205)
 - DC Controller PCA (see figure 6-33)

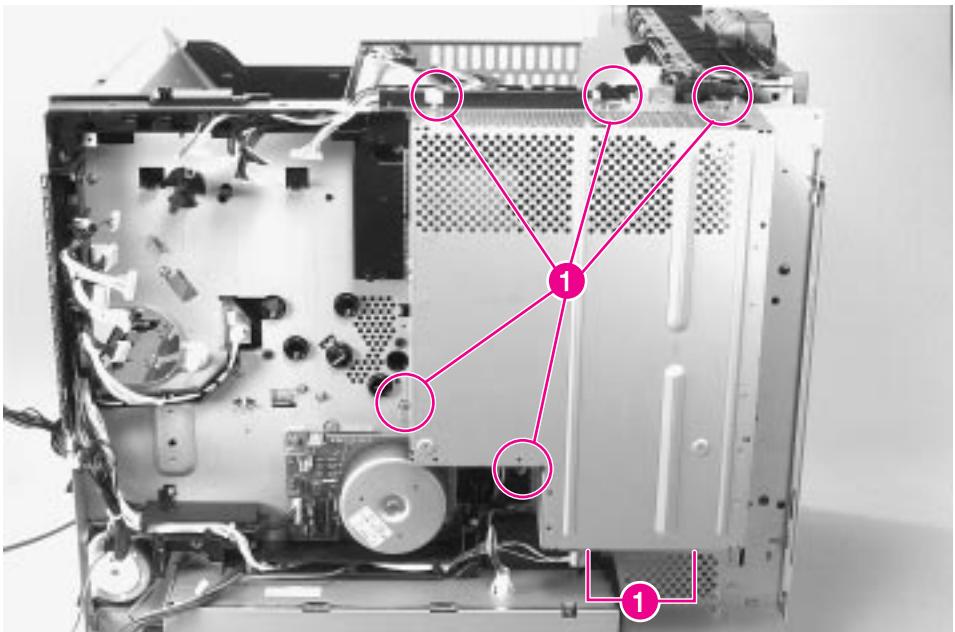

Figure 6-34 Output Paper Sensor PCA (1 of 4)

- 2 Remove 7 screws (figure 6-34, callout 1), and remove the Formatter PCA cage.

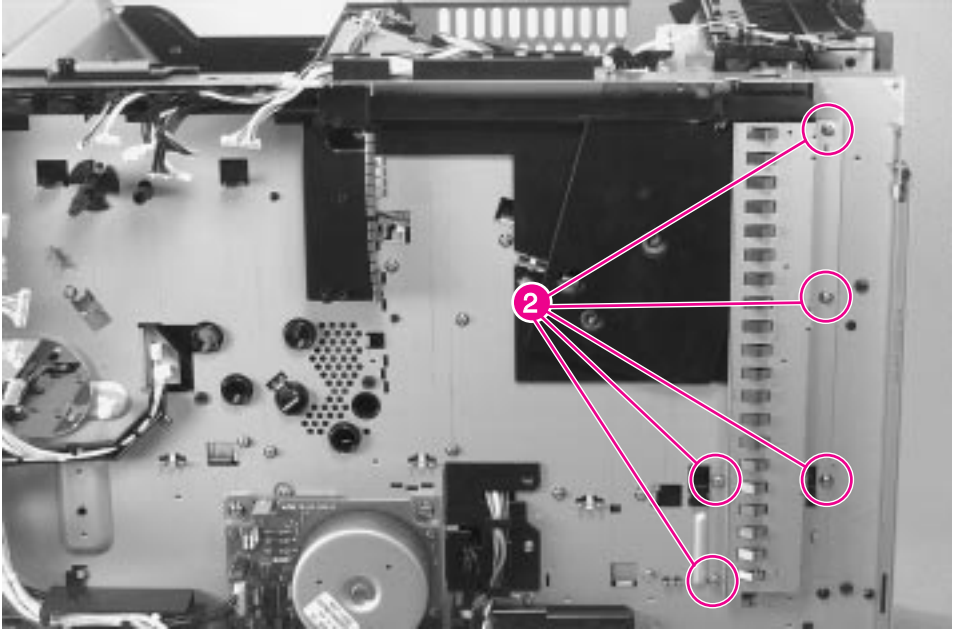

Figure 6-35 Output Paper Sensor PCA (2 of 4)

- 3 Remove 5 screws (figure 6-35, callout 2), and remove the Formatter PCA grounding strip.

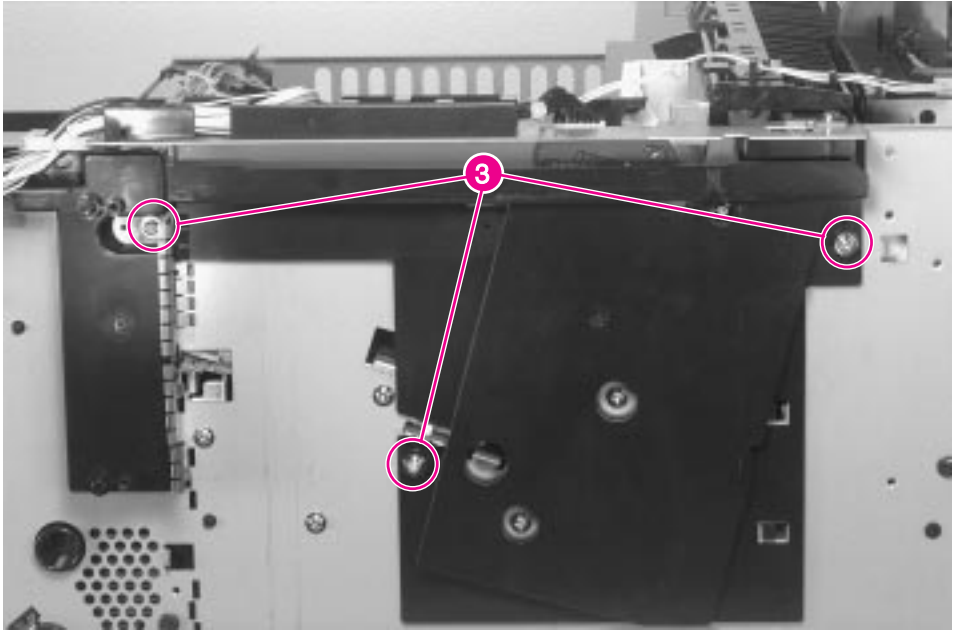

Figure 6-36 Output Paper Sensor PCA (3 of 4)

- 4 Remove 3 screws (figure 6-36, callout 3), and remove the plastic PCA shield. (Note the positioning of the metal grounding fingers at the left of the shield.)

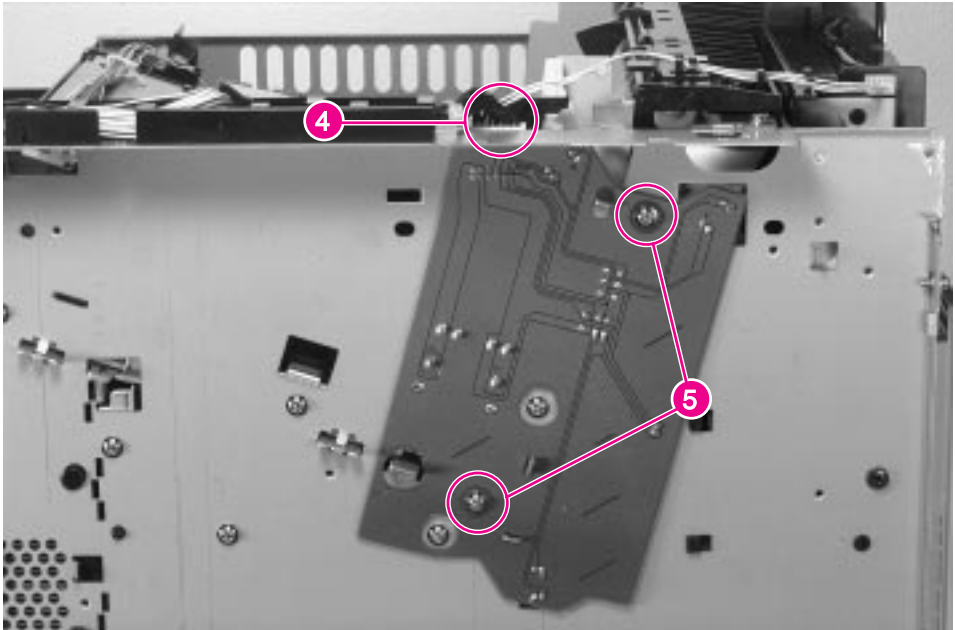

Figure 6-37

Output Paper Sensor PCA (4 of 4)

- 5 Unplug the connector (figure 6-37, callout 4).
- 6 Remove 2 screws (figure 6-37, callout 5), and unplug the connector on the back side of the PCA.

To Reinstall:

Make sure that the sensor flags rotate freely and that the top cover and Diverter doors operate the microswitch (SW1401).

PCA, Paper Size

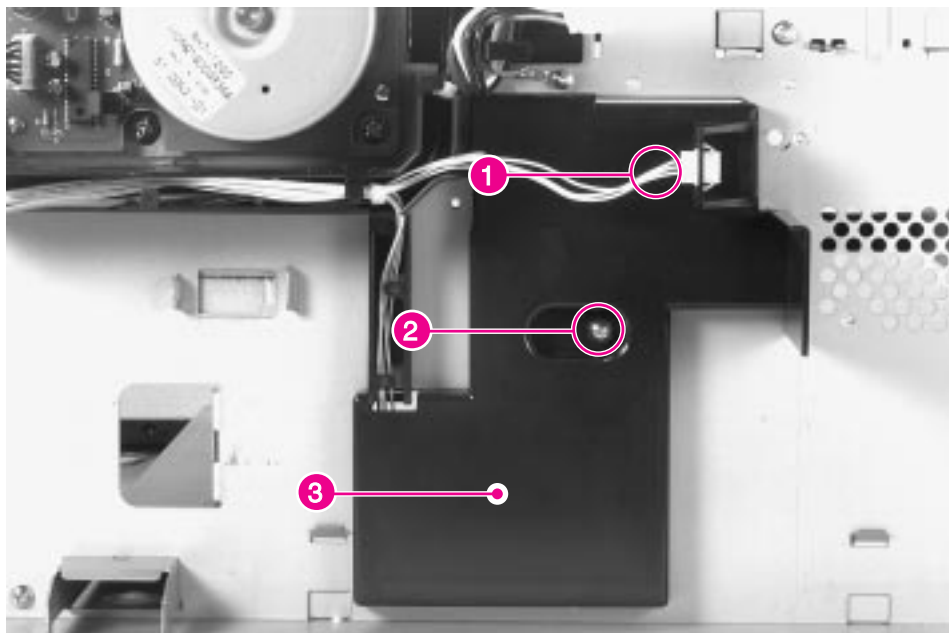

Figure 6-38 Paper Size PCA (1 of 3)

- 1 Remove the following components in the order listed:
 - Toner Cartridge
 - Trays 2 and 3
 - Back Cover (see figure 6-5)
 - Low Voltage Power Supply (LVPS) (see figure 6-42)
- 2 Unplug the fan cable from the left side of the connector (figure 6-38, callout 1), remove 1 screw (figure 6-38, callout 2), and remove the plastic shield (figure 6-38, callout 3).

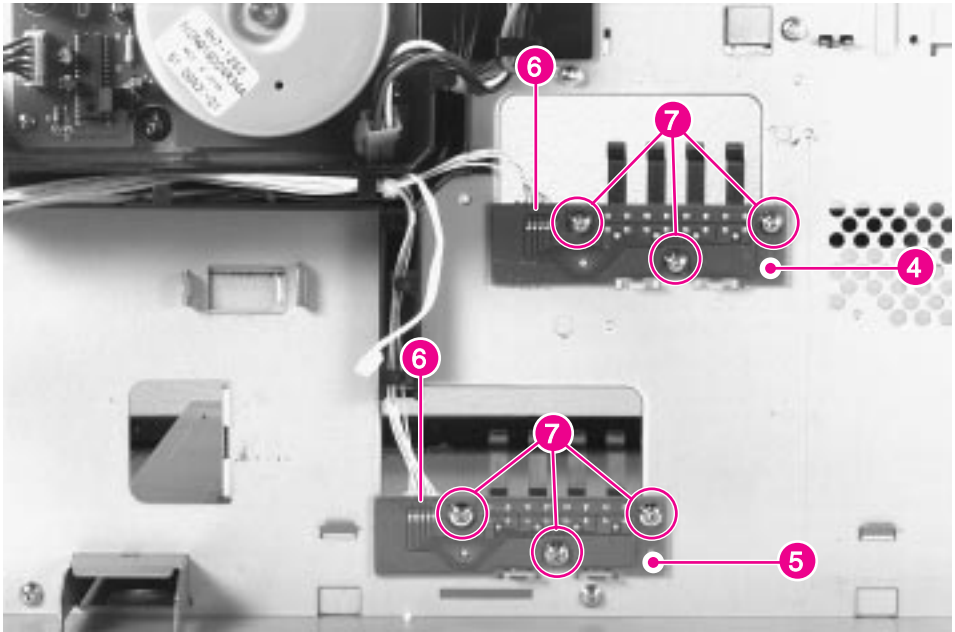

Figure 6-39 Paper Size PCA (2 of 3)

Note

The Paper Size PCA for Tray 2 (figure 6-39, callout 4) is identical to the PCA for Tray 3 (figure 6-39, callout 5). The removal procedure for both PCAs is the same.

- 3 Unplug the connector (figure 6-39, callout 6), remove 3 screws (figure 6-39, callout 7), and remove the PCA and actuating fingers.

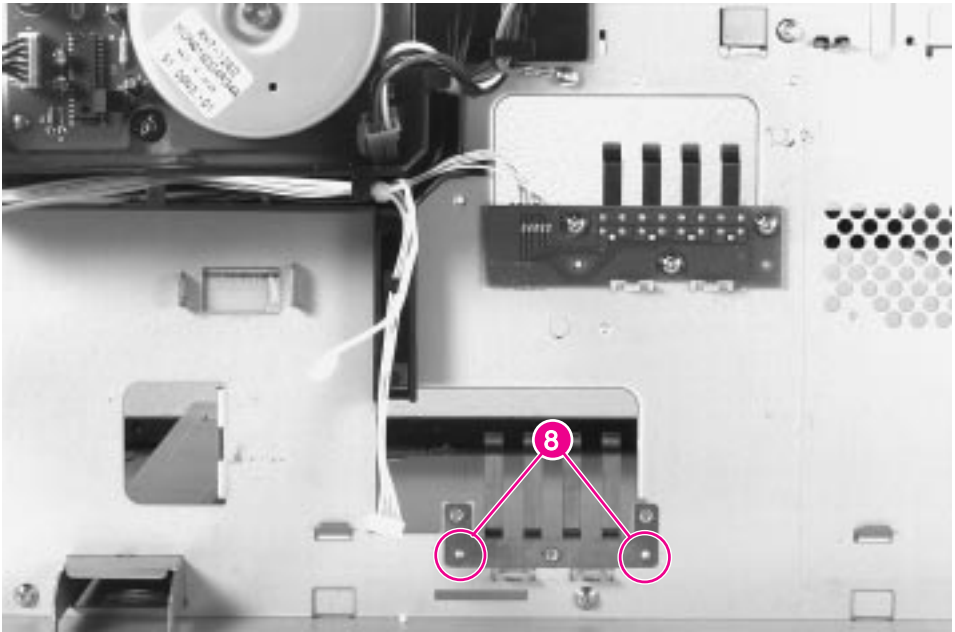

Figure 6-40 Paper Size PCA (3 of 3)

To Reinstall:

Make sure that the actuating fingers are aligned with the locating pins (figure 6-40, callout 8).

Power Supply, High Voltage (HVPS)

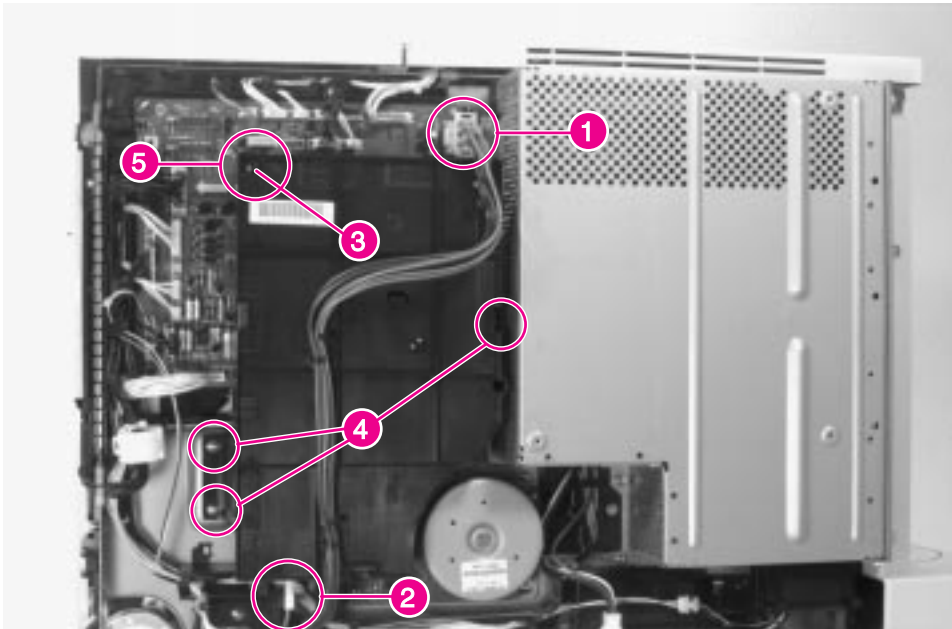

Figure 6-41 High Voltage Power Supply

- 1 Remove the back cover (see figure 6-5 on page 162).
- 2 Unplug the cable from the LVPS to the DC Controller PCA (figure 6-41, callout 1), and move it out of the way.
- 3 Unplug the connector from the bottom of the HVPS (figure 6-41, callout 2).
- 4 Remove 1 self-tapping screw (figure 6-41, callout 3) and 3 screws (figure 6-41, callout 4).

To Reinstall:

Make sure that the plastic alignment pin (figure 6-41, callout 5), the connector pins, and the high voltage contacts are properly aligned before replacing the screws.

Power Supply, Low Voltage (LVPS)

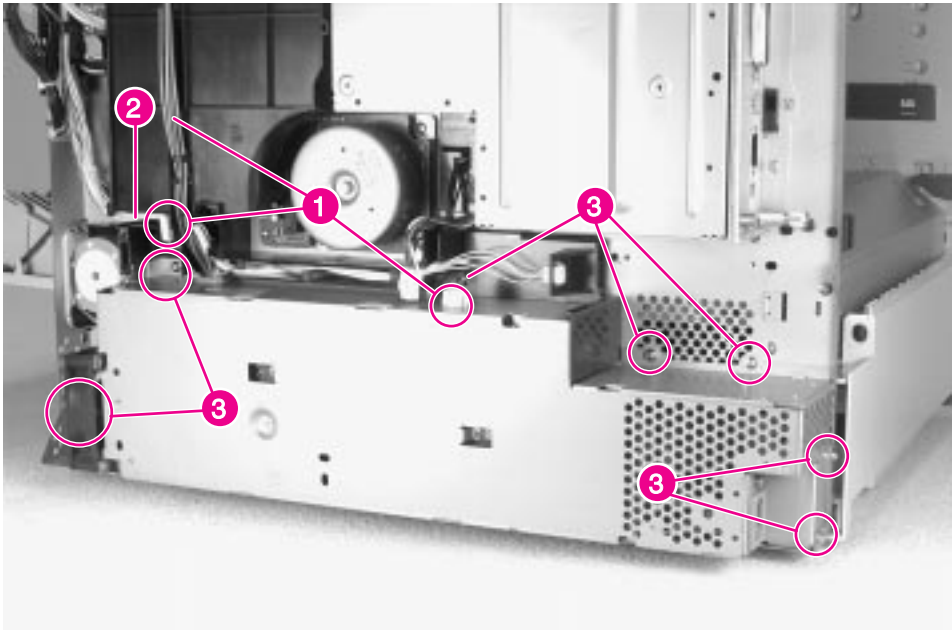

Figure 6-42 Low Voltage Power Supply

- 1 Remove the Formatter Assembly (see figure 6-25 on page 186).
- 2 Remove the back cover (see figure 6-5 on page 162).
- 3 Remove Fan 3 and its Housing Assembly (see figure 6-21).
- 4 Unplug 3 LVPS connectors (figure 6-42, callout 1).
- 5 Unplug the LVPS fan (FM1) cable from the DC Controller (figure 6-42, callout 2).
- 6 Remove 7 screws (figure 6-42, callout 3).

Registration Assembly

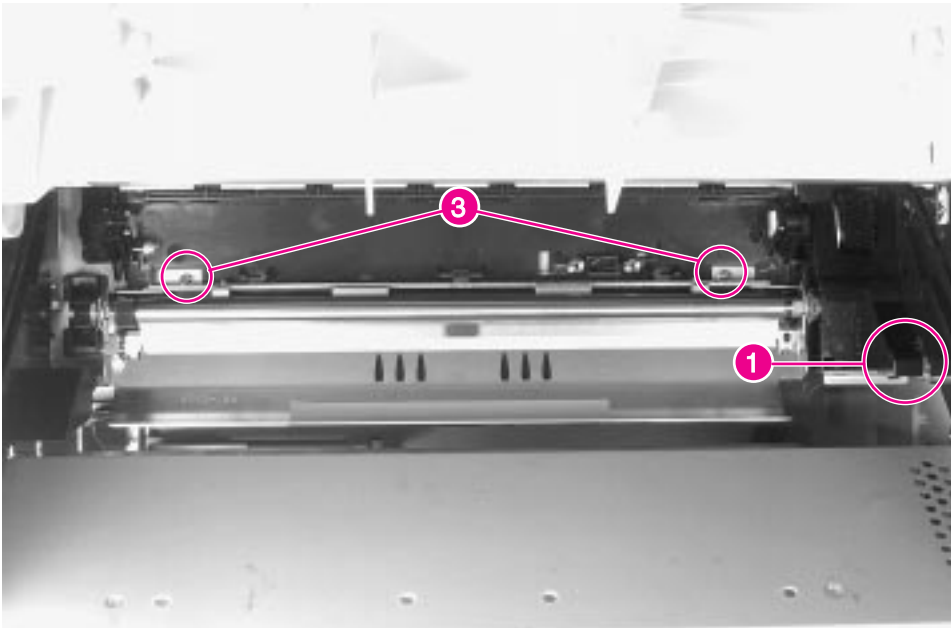

Figure 6-43 Registration Assembly (1 of 3)

- 1 Open the top cover door and remove the toner cartridge.
- 2 Remove the Transfer Roller Assembly (see figure 6-52 on page 219).
- 3 Remove the Main Gear Train Shield. Release the retainer clip (figure 6-43, callout 1), and lift the forward end up.

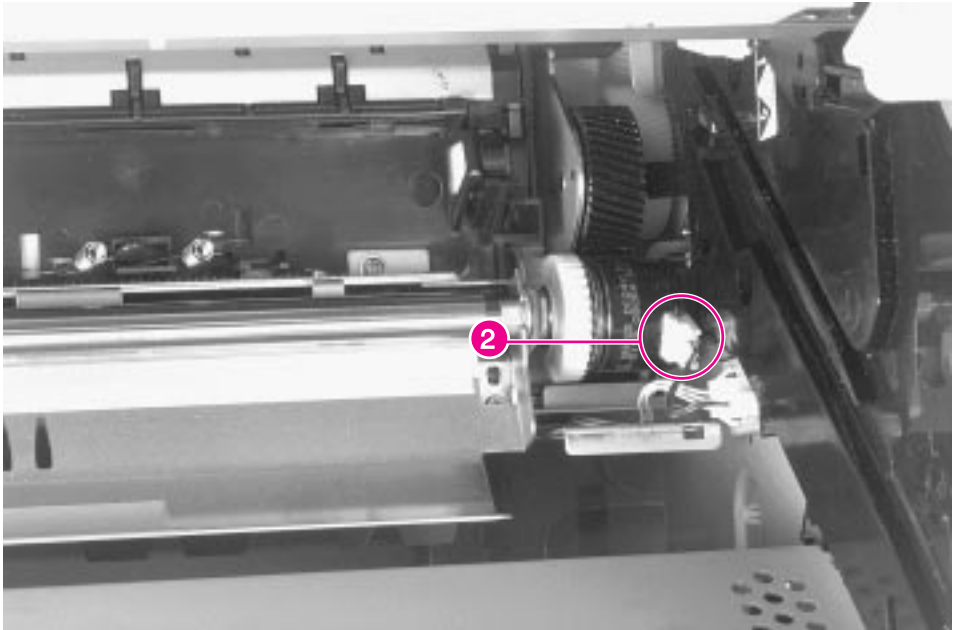

Figure 6-44 Registration Assembly (2 of 3)

- 4 Unplug the clutch cable from the clutch on the right end of the Registration Assembly (figure 6-44, callout 2).
- 5 Remove 2 screws at rear of assembly (figure 6-43, callout 3).

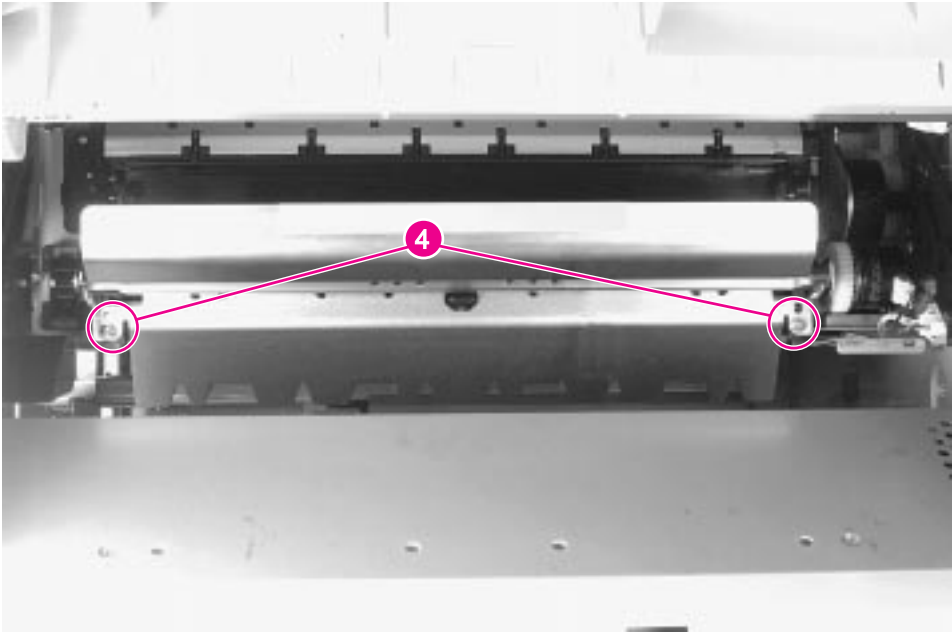

Figure 6-45 Registration Assembly (3 of 3)

- 6 Lift the registration guide and remove 2 screws at the front of the assembly (figure 6-45, callout 4).

To Reinstall:

- 1 Lift the registration guide, and place the Registration Assembly into position.
- 2 Lift the registration guide and make sure that the locator pin near the right screw is properly positioned.
- 3 Make sure that the grounding strap is under the left screw.
- 4 Be sure to connect the clutch cable connector.
- 5 After replacing the 4 screws, replace the Main Gear Train Shield. Tilt the top outward, tuck the lower tabs in place, and snap the cover down into position.

Roller and Separation Pad, Tray 1

Feed Roller

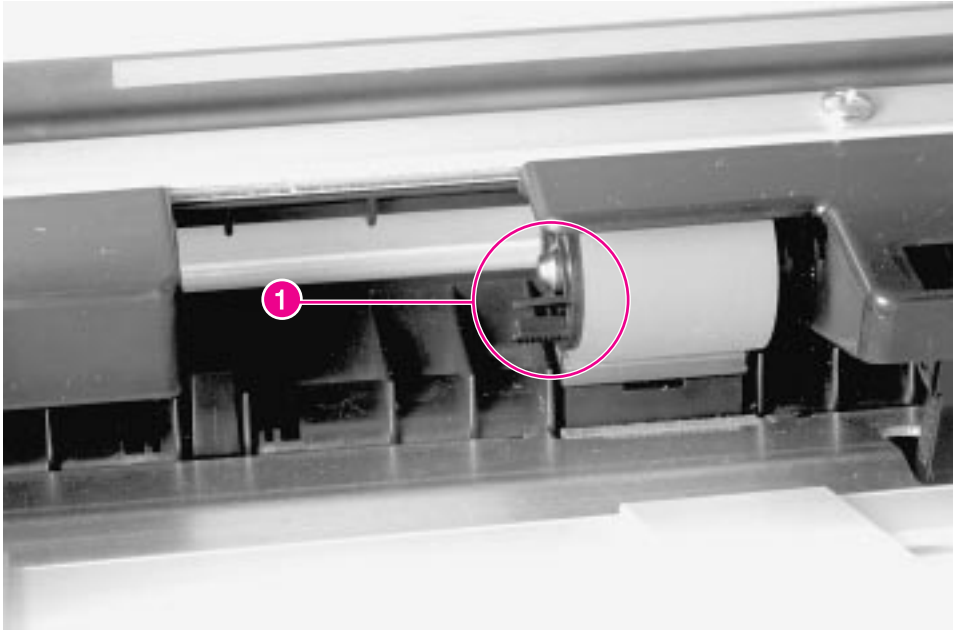

Figure 6-46 Tray 1 Feed Roller

- 1 Open the Tray 1 door, and remove the plastic shield.
- 2 Pinch the retainer tabs together (figure 6-46, callout 1), and slide the roller to the left off of the shaft.

Separation Pad

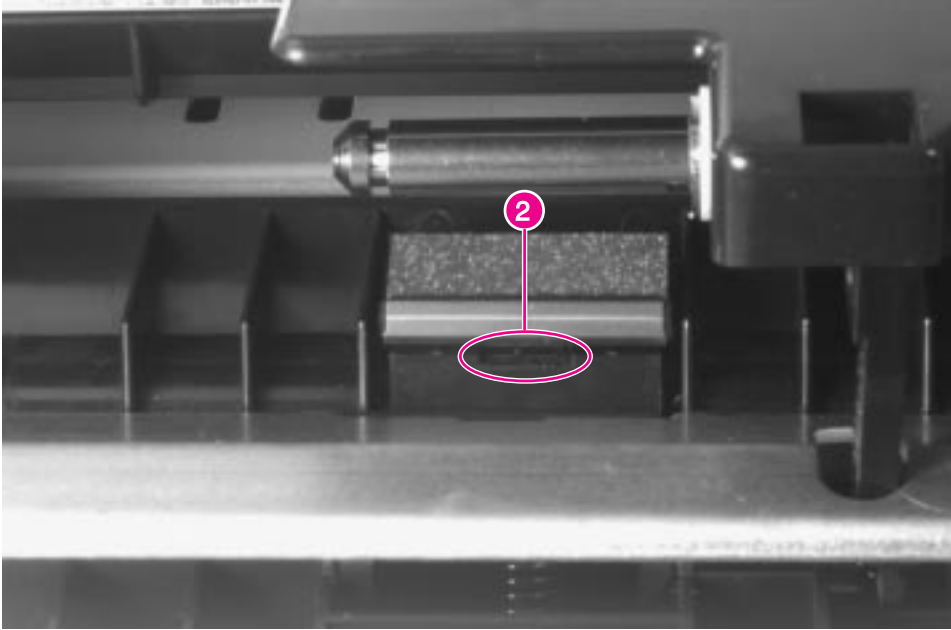

Figure 6-47 Tray 1 Separation Pad

- 1 Open the Tray 1 door, and remove the Feed Roller.
- 2 Insert a flat-bladed screwdriver into the slot (figure 6-47, callout 2), and carefully pry the separation pad upwards out of its retaining notches.

To Reinstall:

Make sure the metal edge of the Separation pad faces forward.

Rollers: Tray Pickup, Feed, and Separation

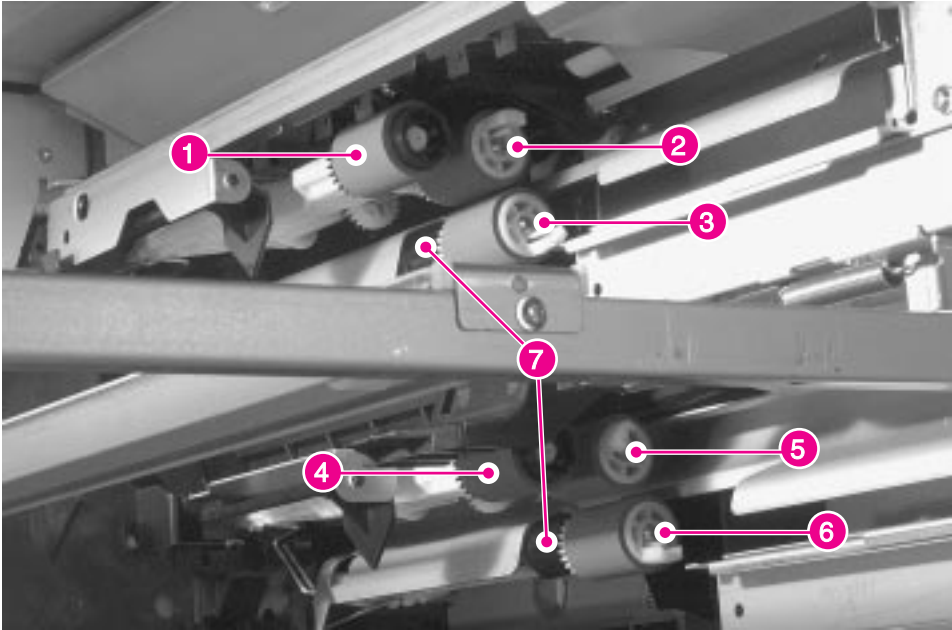

Figure 6-48 Tray 2 and 3, Pickup, Feed, and Separation Rollers

Note

There are three rollers for each tray: the Pickup Roller, the Feed Roller, and the Separation Roller. The Feed and Separation Rollers are interchangeable with each other and between trays. The Pickup Rollers are interchangeable between trays.

- Tray 2 Pickup Roller: figure 6-48, callout 1
- Tray 2 Feed Roller: figure 6-48, callout 2
- Tray 2 Separation Roller: figure 6-48, callout 3
- Tray 3 Pickup Roller: figure 6-48, callout 4
- Tray 3 Feed Roller: figure 6-48, callout 5
- Tray 3 Separation Roller: figure 6-48, callout 6

1 Remove Trays.

Note

The Feed and Separation rollers have protruding tabs, and the pickup rollers have recessed retaining tabs. Be careful not to lose the plastic torque limiters located behind the Separation Rollers (figure 6-48, callout 7).

2 From inside the tray cavity, remove the rollers by pinching the retainer tabs together and sliding the roller off the shaft.

Sensor, Paper Input Unit (PS2)

- 1 Remove the following components in the order listed:
 - Toner Cartridge
 - Trays 2 and 3
 - Transfer Roller (see figure 6-52 on page 219)
 - Registration Assembly (see figure 6-44 on page 208)
 - Front Cover (see figure 6-6 on page 163)
 - Tray 1 Assembly (see figure 6-53 on page 221)
 - Right Lower Door Assembly (see figure 6-15 on page 174)

Note

The sensor retaining tabs are released from above, and the sensor is removed and replaced from below.

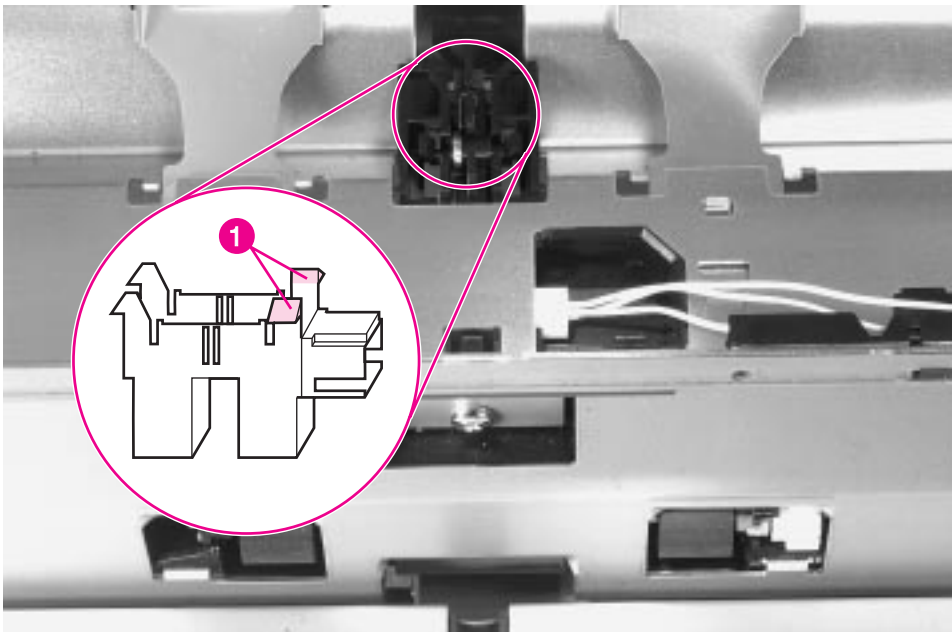

Figure 6-49 Paper Input Unit Sensor (PS2)

- 2 Release the retaining tabs (figure 6-49, callout 1) on the right end of the sensor, and rotate the sensor down to free the tabs on the left end.
- 3 Unplug the connector from the sensor.

To Reinstall:

- 1** Plug in the connector before reinstalling.
- 2** Holding the sensor flag out of the way, first hook the tabs on the left end in first. Snap the right end of the sensor upward into place.

Sensor, Registration (PS1)

- 1 Remove the following components in the order listed:
 - Toner Cartridge
 - Trays 2 and 3
 - Transfer Roller (see figure 6-52 on page 219)
 - Registration Assembly (see figure 6-44 on page 208)
 - Front Cover (see figure 6-6 on page 163)
 - Tray 1 Assembly (see figure 6-53 on page 221)
 - Right Lower Door Assembly (see figure 6-15 on page 174)
 - Paper Input Unit (see figure 6-32 on page 195)

Note

The sensor retaining tabs are released from above, and the sensor is removed and replaced from inside the Paper Input Unit cavity.

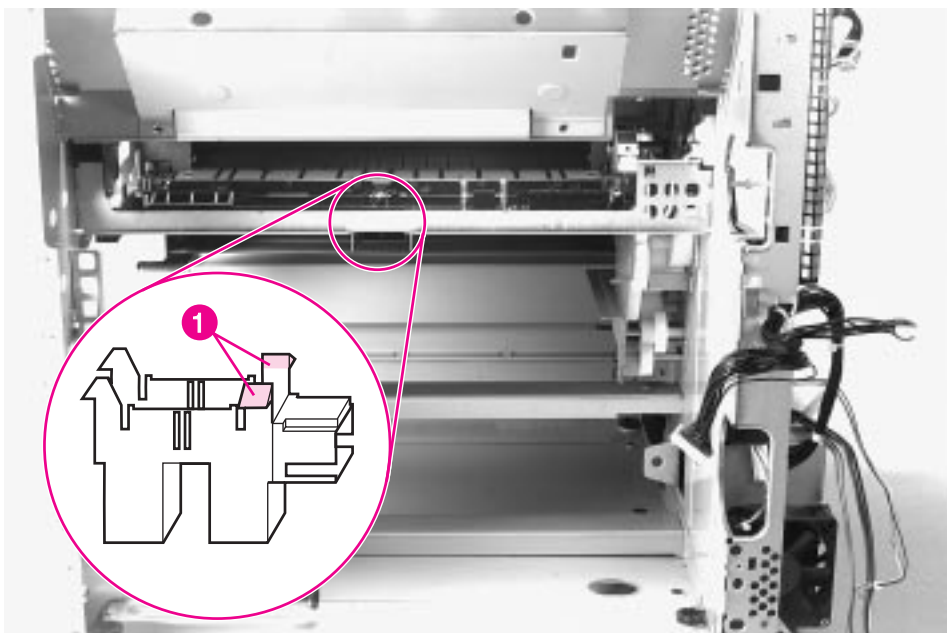

Figure 6-50 Registration Sensor (PS1)

- 2 Release the retaining tabs (figure 6-50, callout 1) on the right end of the sensor and rotate the sensor down to free the tabs on the left end of the sensor.
- 3 Unplug the connector from the sensor.

To Reinstall:

- 1** Plug in the connector.
- 2** Holding the sensor flag out of the way, first hook the tabs on the left end in first. Snap the right end of the sensor upward into place.

Solenoid Assembly, SL3 (Face-Up)

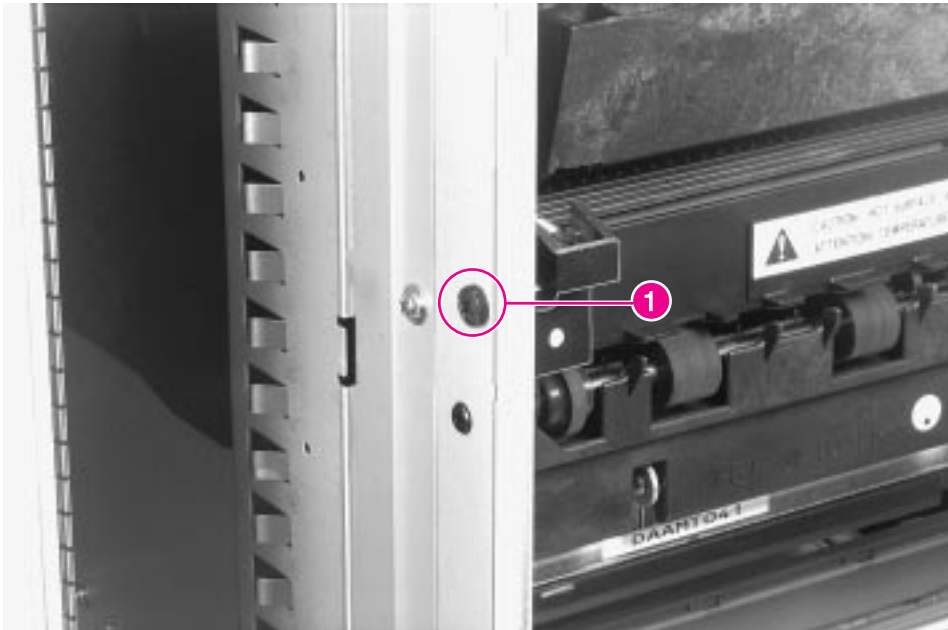

Figure 6-51 Face-Up Solenoid Assembly, SL3

- 1 Remove the top cover (see figure 6-9 on page 166).
- 2 Remove the Delivery Unit (see figure 6-11 on page 169).
- 3 Remove 1 self-tapping screw (figure 6-51, callout 1).

CAUTION

Be careful not to damage the plastic arm when removing the assembly.

- 4 Pull the forward end of the assembly away from the chassis to clear the locating pin, and slide it forward to clear two retaining tabs.

Transfer Roller Assembly

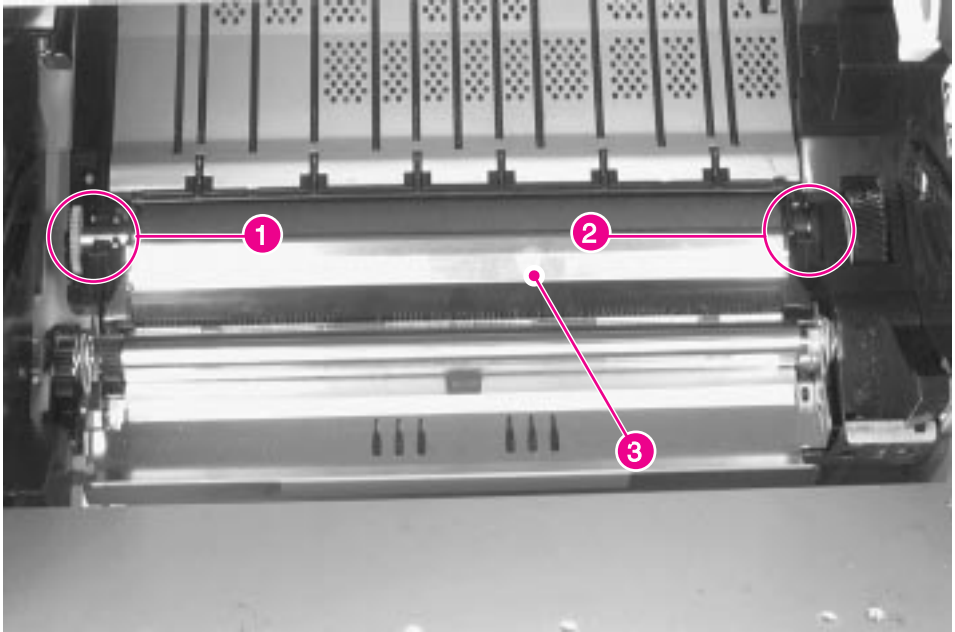

Figure 6-52 Transfer Roller Assembly

CAUTION

Handle the Transfer Roller from the ends only. Do not touch the surface of the Transfer Roller. Skin oils will affect its electrical characteristics, resulting in poor image transfer.

- 1 Open the top cover door, and remove the toner cartridge.
- 2 Grasp the gear (figure 6-52, callout 1) on the left end, and carefully lift upward just enough to clear the retainer clip.
- 3 Slide the Transfer Roller Assembly to the left to release the shaft on the right end (figure 6-52, callout 2).

To Reinstall:

- 1 Place the right end of the shaft into its retaining cavity.
- 2 Hold the Transfer Roller wiper up (figure 6-52, callout 3) and slide the assembly to the right until the gear on the left end is in position.
- 3 Carefully press the left end of the shaft into the retainer clip.
- 4 Press the Transfer Roller wiper down (figure 6-52, callout 3) until the retaining clips snap into place.

Tray 1 Assembly

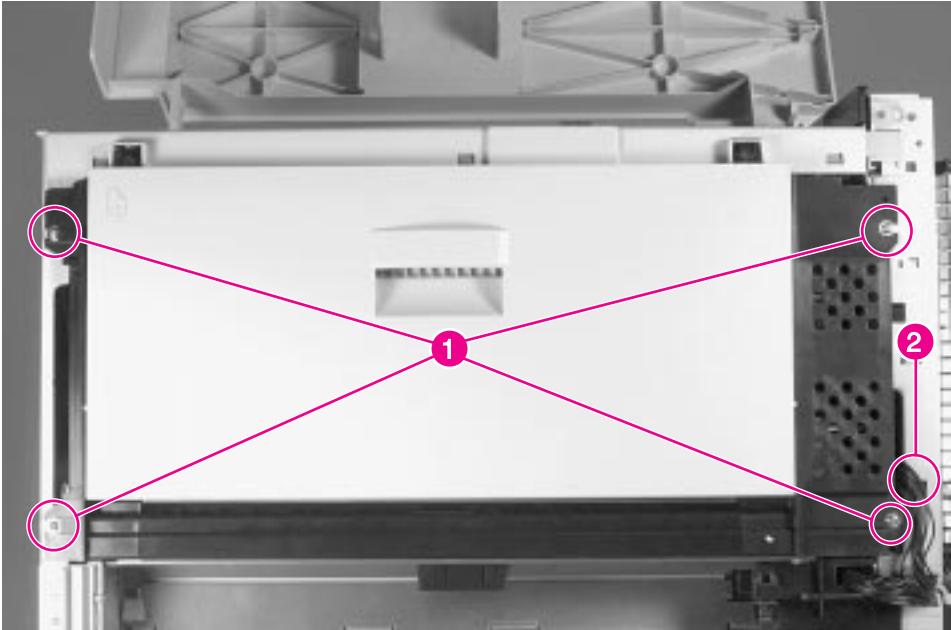

Figure 6-53 Tray 1 Assembly

- 1 Remove the front cover (see figure 6-6 on page 163) and the back cover (see figure 6-5 on page 162).
- 2 Open the top cover, and remove the toner cartridge.
- 3 Open the right lower door.
- 4 Remove 4 screws (figure 6-53, callout 1).
- 5 Carefully pull the assembly out from the printer, and unplug the connector inside the right end (figure 6-53, callout 2).
- 6 Continue sliding the assembly out of the printer chassis.

To Reinstall:

Make sure that the alignment pins and plastic gears are properly aligned.

Tray 2 and 3 Assemblies

Note

The paper trays are mechanically aligned to the printer chassis at the factory. If you are replacing Tray 2 or Tray 3 with a tray other than the original factory installed unit, you may have to adjust the new tray. For details, see “Tray Adjustment Procedure” on page 92.

- 1 Open the tray, and pull it out to the stop.
- 2 Carefully lift up on the outer end to release the tray stop mechanism at the right rear while continuing to pull the tray free of the chassis.

To Reinstall:

- 1 Align the left rear corner of the tray and the locating track at the lower rear center of the tray with their respective guides, and insert the tray no more than two inches into the chassis.
- 2 Carefully lift up on the outer end of the tray while pulling the tray stop mechanism, located at the right rear of the tray opening, out and over the tray roller and guide assembly.
- 3 Carefully slide the tray into the printer until it latches into place.

Mailbox With Stapler

Covers

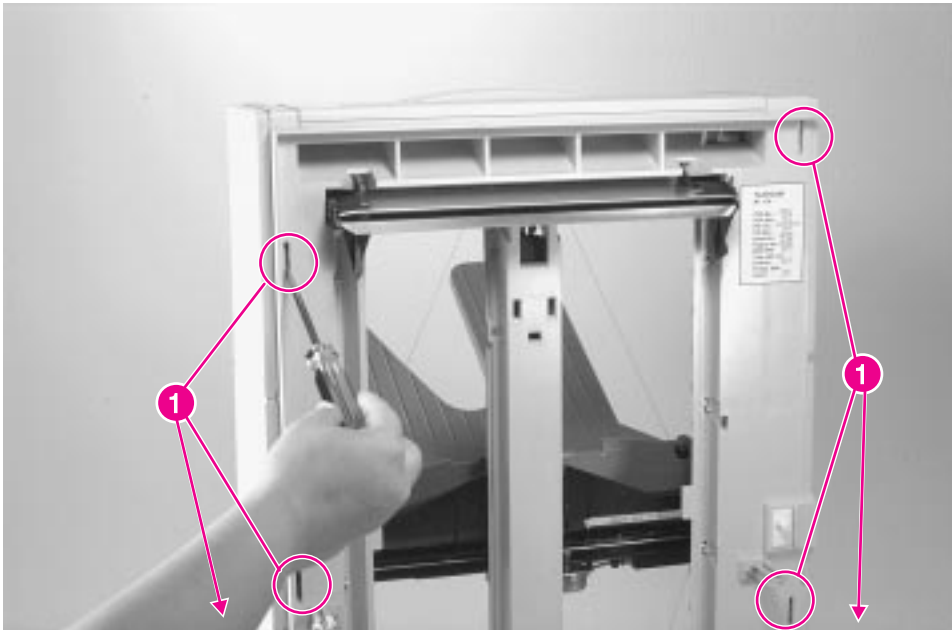

Figure 6-54 Mailbox with Stapler Covers

The procedure for removing the left and right covers is the same.

- 1 Using a small flat-blade screwdriver, release 3 retaining tabs (figure 6-54, callout 1) along the rear edge of the cover, and rotate the cover clear of the frame.

To Reinstall:

Make sure that the retaining tabs along the front edge are in place and snap the rear edge of the cover into position.

Delivery Head Assembly

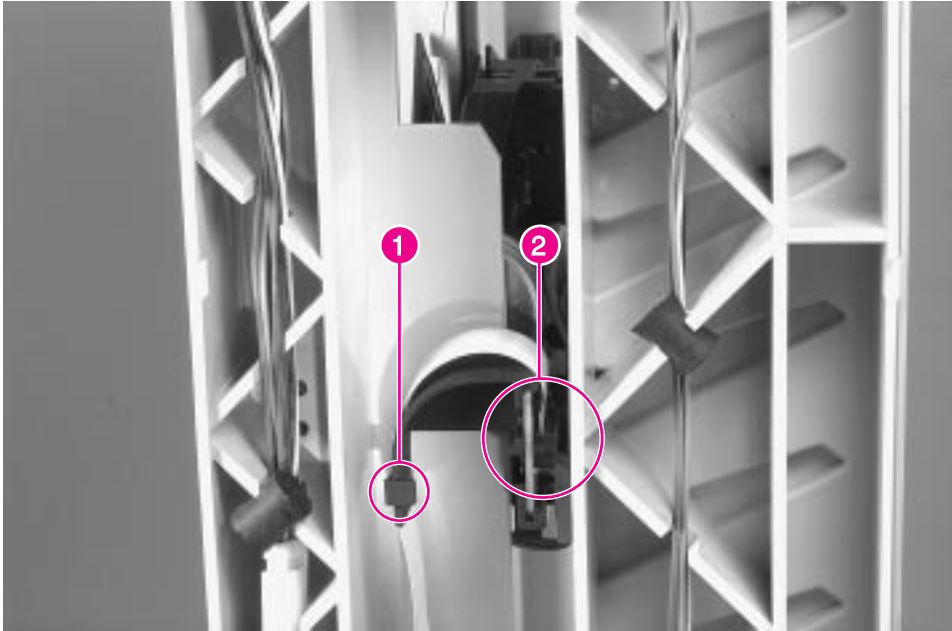

Figure 6-55 Mailbox with Stapler, Delivery Head Ribbon Cable

- 1 Remove the left cover (see figure 6-54 on page 223).
- 2 Remove all paper bins and the blind cover (see figure 6-75 on page 244) or the stapler (see figure 6-80 on page 249).
- 3 Release the top of the Metallic Tape (see figure 6-68 on page 237).
- 4 Unlock the cable clip (figure 6-55, callout 1), and unplug the ribbon cable (figure 6-55, callout 2) from the left end of the Delivery Head Assembly.
- 5 Raise the Delivery Head Mechanism to the top of the frame.

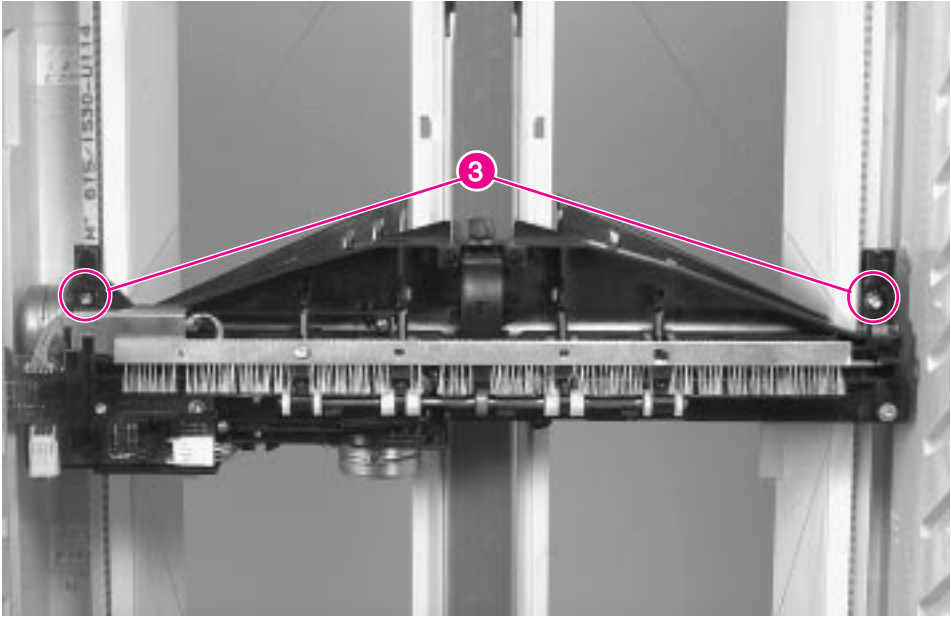

Figure 6-56 Mailbox with Stapler, Delivery Head Mounting Screws

- 6 Support the Delivery Head Mechanism, and remove 4 screws (figure 6-56, callout 3).
- 7 Rotate the right end of the assembly forward while guiding the left end through its access opening.

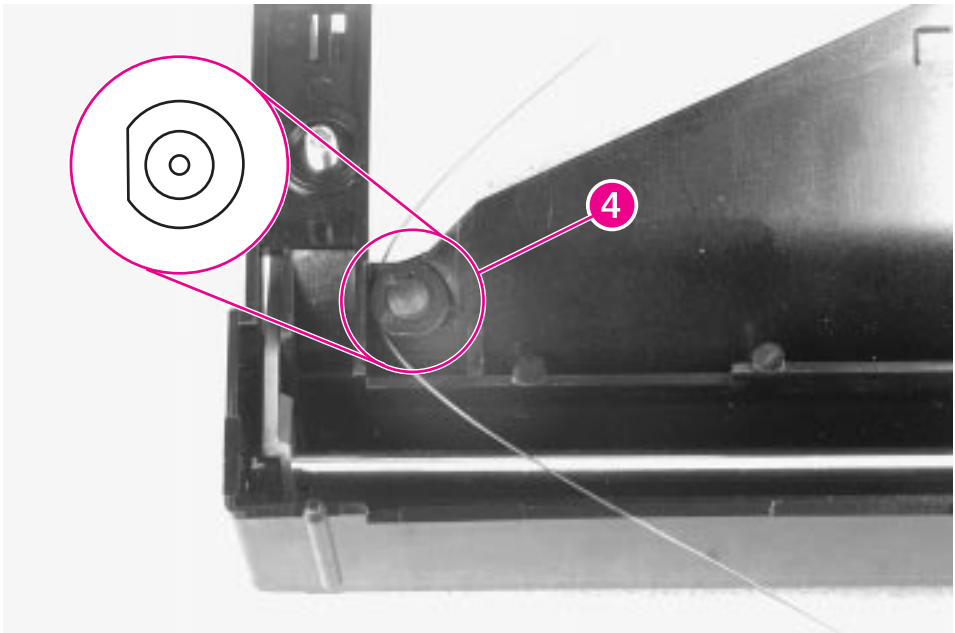

Figure 6-57 Mailbox with Stapler, Delivery Head Pulley Detail

- 8 Release the Anti-Curl Strings from the pulleys on the back of the assembly (figure 6-57, callout 4) by removing the mounting pin from the center.

To Reinstall:

- 1 Replace the Anti-Curl Strings into the pulleys on the back of the assembly. (You may need to release the Anti-Curl String Springs at the bottom of the frame to have enough slack.)
- 2 Carefully replace the ribbon cable into its connector.
- 3 Insert the left end of the assembly through its access opening and position the assembly onto its elevator mounts. Make sure that the locating pins are in place.
- 4 Replace the 2 screws.
- 5 Reattach the Anti-Curl String Springs at the bottom of the frame.

Flipper Assembly



Figure 6-58 Mailbox with Stapler, Flipper Assembly Connector



Figure 6-59 Mailbox with Stapler, Flipper Assembly Mounting Screws

- 1 Remove all paper bins and the blind cover (see figure 6-75 on page 244).
- 2 Remove the Left and Right Covers (see figure 6-54 on page 223).
- 3 Remove the Delivery Head Position Motor (see figure 6-71 on page 240).
- 4 Remove the Jam Access Door (see figure 6-63 on page 232 through figure 6-65 on page 234).
- 5 Remove the 2 inside screws closest to the front of the unit (figure 6-59, callout 2).

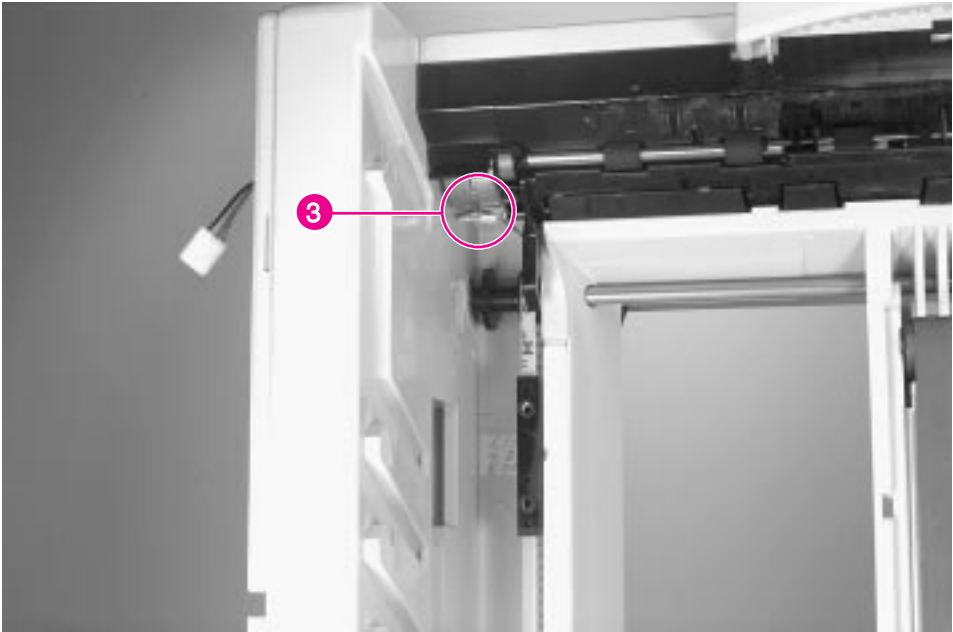

Figure 6-60 Mailbox with Stapler, Flipper Assembly Ground Wire

- 6 Unplug the ground wire from the Flipper Roller Motor (figure 6-60, callout 3).
- 7 Tilt the right end of the assembly a few inches out of the frame, unplug the cable (see figure 6-58 on page 227, callout 1), and rotate the assembly free while feeding the motor cable out through the access opening on the left side.

To Reinstall:

CAUTION

Do not over tighten the screws (figure 6-59 on page 228, callout 2), when replacing the Flipper Assembly. The nuts in the Flipper Assembly will rotate in their retaining slots.

Input Paper Guide

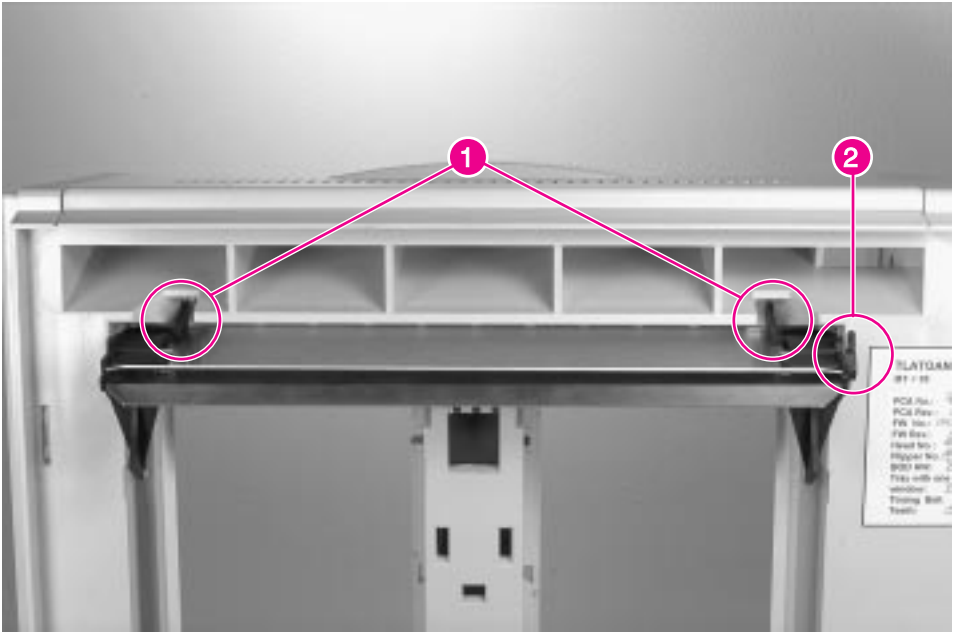

Figure 6-61 Mailbox with Stapler, Input Paper Guide

- 1 Remove the paper bins and the blind cover (see figure 6-75).
- 2 Open the Jam Access Door, and disconnect the ground wire from the bottom of the Flipper Roller Motor (figure 6-60, callout 3).
- 3 From the rear of the unit, release the Paper Guide retaining tabs (figure 6-61, callout 1).
- 4 Carefully pull the paper guide free of the frame while routing the ground wire through the access hole (figure 6-61, callout 2).

Interlock Switch

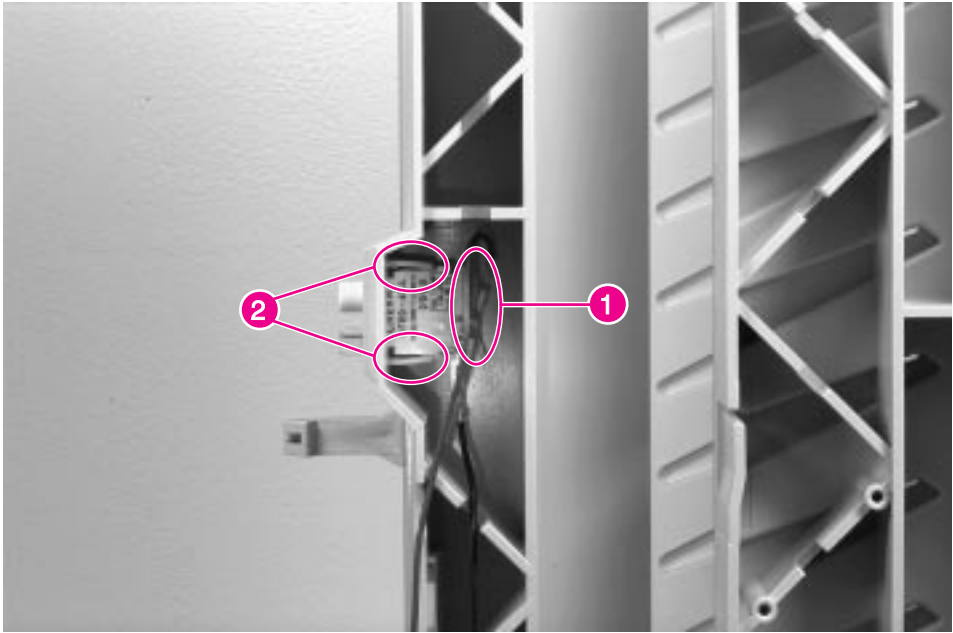

Figure 6-62 Mailbox with Stapler, Interlock Switch

- 1 Remove the left cover (see figure 6-54).
- 2 Disconnect 2 wires from the Interlock Switch (figure 6-62, callout 1).
- 3 Press the retainer tabs together (figure 6-62, callout 2) to release the switch, and remove it from the rear of the unit.

Jam Access Door Assembly

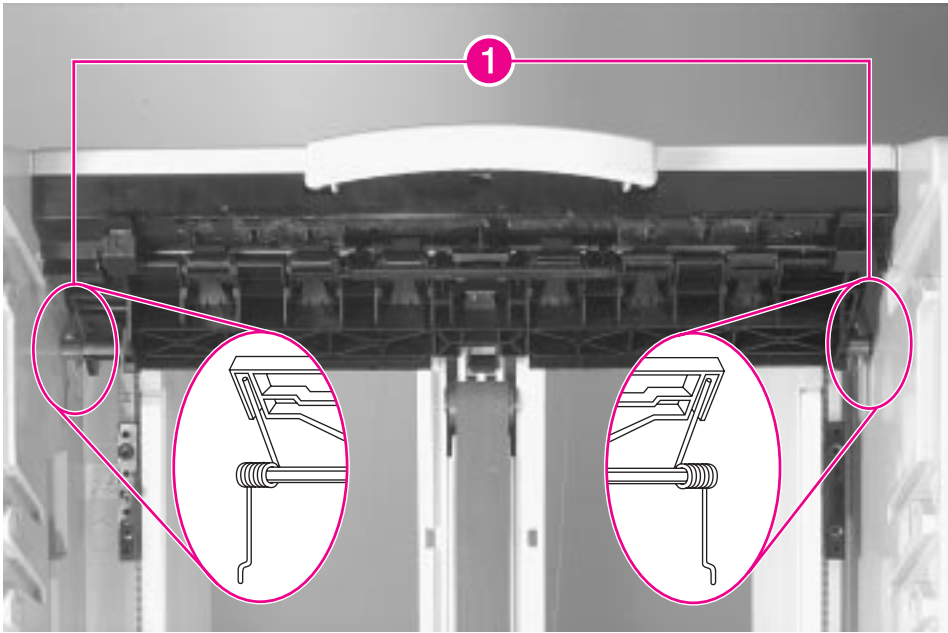

Figure 6-63 Mailbox with Stapler, Jam Access Door Springs

- 1 Remove the left and right covers (see figure 6-54 on page 223).
- 2 Remove the Delivery Head Position Motor (see figure 6-71 on page 240).
- 3 Remove all paper bins and the blind cover (see figure 6-75 on page 244).
- 4 Release the upper end of the Metallic Tape (see figure 6-68 on page 237).
- 5 Release 2 retaining springs (figure 6-63, callout 1).

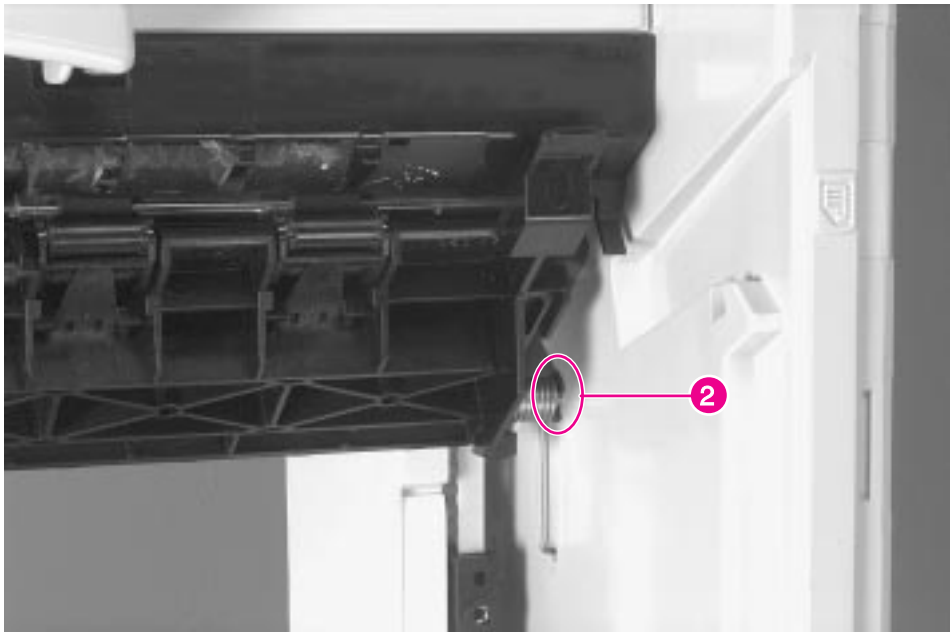

Figure 6-64 Mailbox with Stapler, Jam Access Door E-Clip

- 6 From the front of the unit, remove 1 e-clip from the right end of the shaft (figure 6-64, callout 2).

CAUTION

Use caution when removing the e-clip because the clip might eject towards you or another person.

Note

Before removing the Jam Access Door six-sided shaft, note the position of the plastic retainer that holds the metallic tape located at the center of the door. It must be replaced on the shaft in the same position for proper paper movement.

- 7 From the front of the unit, support the door assembly while sliding the shaft to the left until it is clear of the frame. The retaining springs and tape retainer will fall free.

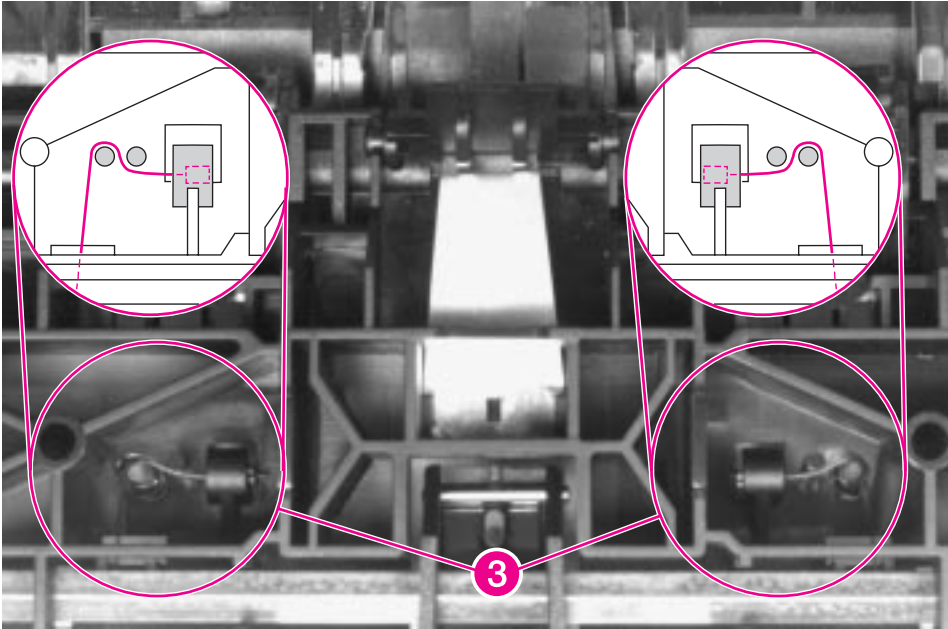

Figure 6-65 Mailbox with Stapler, Jam Access Door String Connection

- 8 Release the upper ends of the Paper Guide Strings (figure 6-65, callout 3) from the assembly.

To Reinstall:

- 1 Attach the upper ends of the Paper Guide Strings to the door assembly before installing it into the frame.
- 2 Make sure that the retaining springs and the tape retainer are properly positioned as you insert the shaft into the frame.
- 3 Make sure that the retaining springs, e-clip, and copper grounding plate are properly replaced on the shaft in the same position in which they were removed.

Lower Elevator Pulley Assemblies

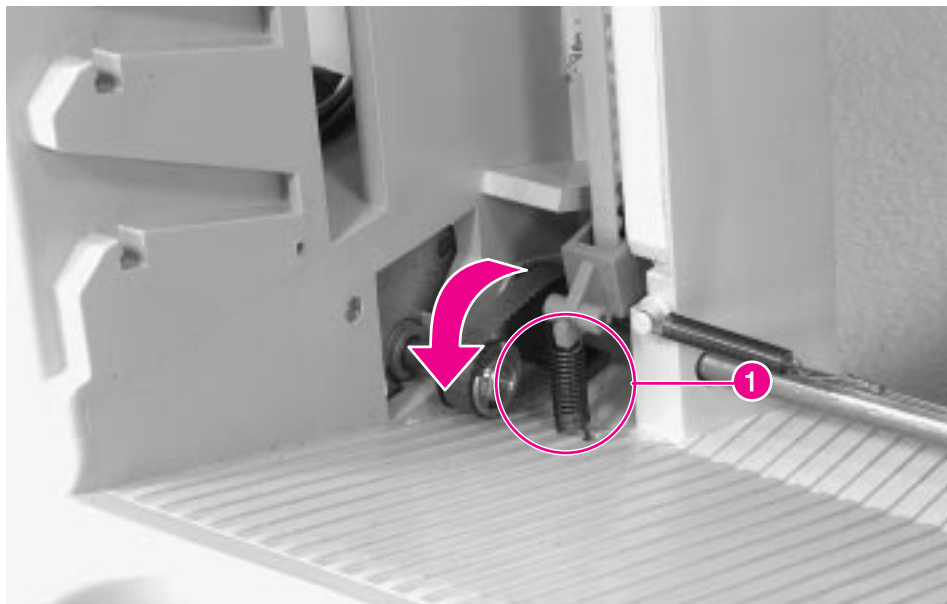

Figure 6-66 Mailbox with Stapler, Elevator Pulley Tension Spring

- 1 Remove all paper bins and the blind cover (see figure 6-75 on page 244).
- 2 From the front of the unit, disconnect 2 tension springs (figure 6-66, callout 1).

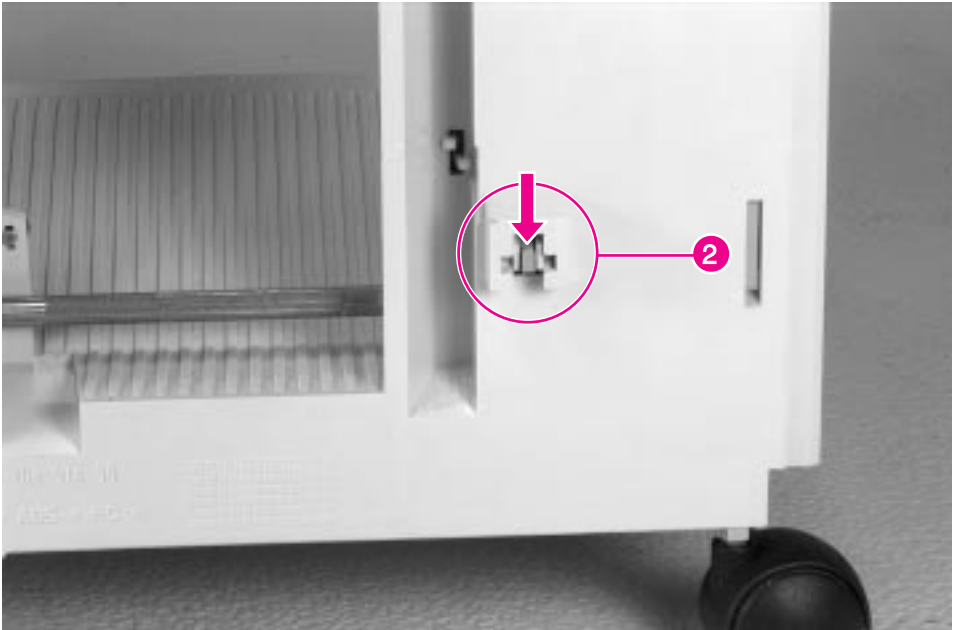

Figure 6-67 Mailbox with Stapler, Pulley Housing Release

- 3 From the back of the unit, release 2 lower pulley assemblies by pushing down on the assembly, and then pushing it forward (figure 6-67, callout 2). Note that the protrusion on the side of the pulley housing is positioned toward the outside of the frame.
- 4 Release the elevator belt from the pulley assembly by pushing downward on the pulley until the pulley shaft falls free. Note that the flattened end of the pulley shaft is positioned toward the outside of the frame.

To Reinstall:

- 1 Make sure that the locating tabs in the pulley halves fit exactly into their mating notches. When properly assembled, the pulley halves will not rotate relative to each other.
- 2 Make sure that the pulley housings are positioned with the shaft protrusion toward the outside of the frame.
- 3 Make sure to reconnect the lower tension springs.

Metallic Tape and Housing Assembly

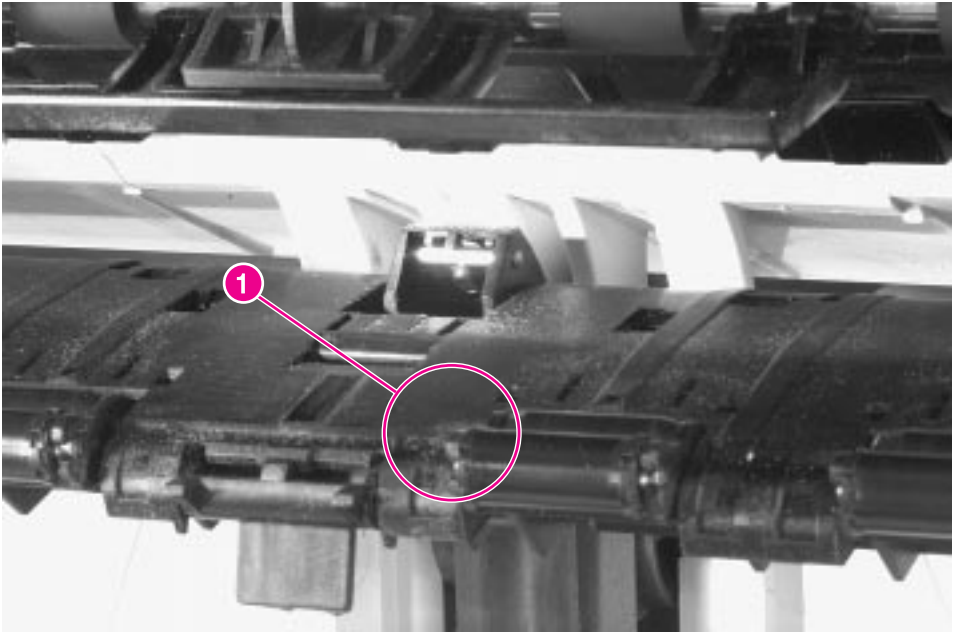

Figure 6-68 Mailbox with Stapler, Metallic Tape Retaining Pin

- 1 Remove all paper bins and the blind cover (see figure 6-75 on page 244).
- 2 Lower the Delivery Head to the bottom of the frame.
- 3 Release the tape retainer by pushing the tab (see figure 6-68, callout 1).

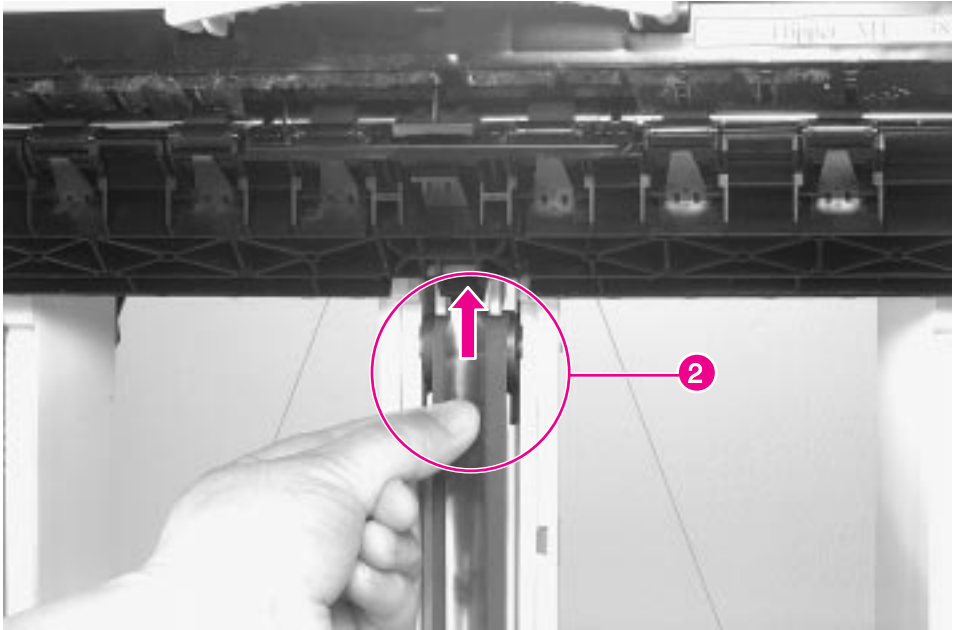

Figure 6-69 Mailbox with Stapler, Metallic Tape Release

- 4 Carefully rewind the tape into its housing. Do not allow the tape to freely snap back into the housing (see figure 6-69, callout 2).

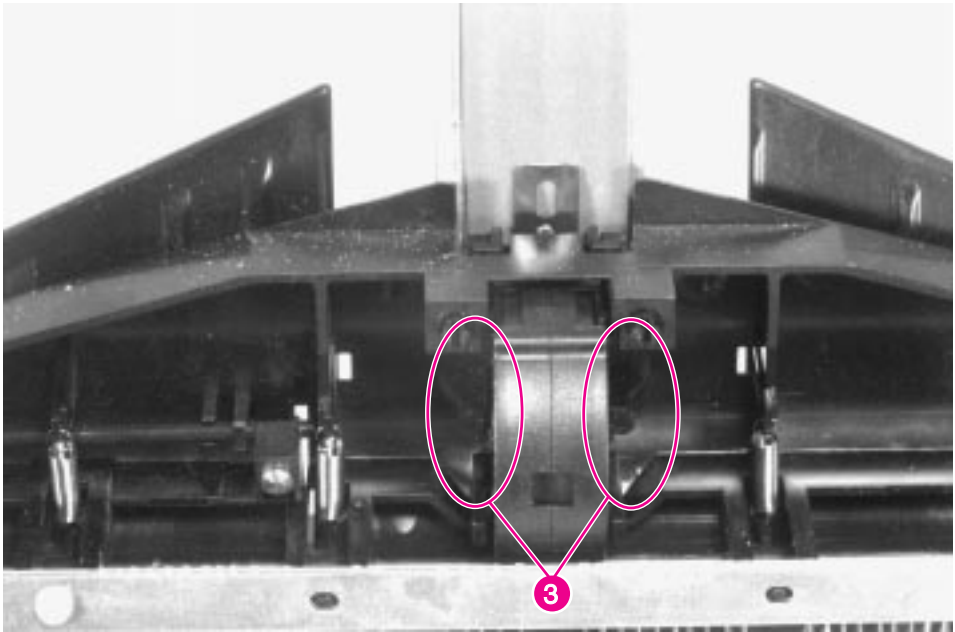

Figure 6-70 Mailbox with Stapler, Metallic Tape Housing

- 5 Remove the tape housing by releasing the retaining tabs (figure 6-70, callout 3) and rotating it upward.

To Reinstall:

- 1 Replace the tape housing by inserting the top of the housing into position, and snapping the housing down into place. Make sure that the tape is in direct contact with the Transport Belt by routing it underneath the small plastic guide.
- 2 Insert the top end of the tape into its retainer slot, and gently push it upward to engage the retainer tab. Before replacing the tape holder, make sure that the tape is in direct contact with the Transport Belt.

Motor, Delivery Head Position

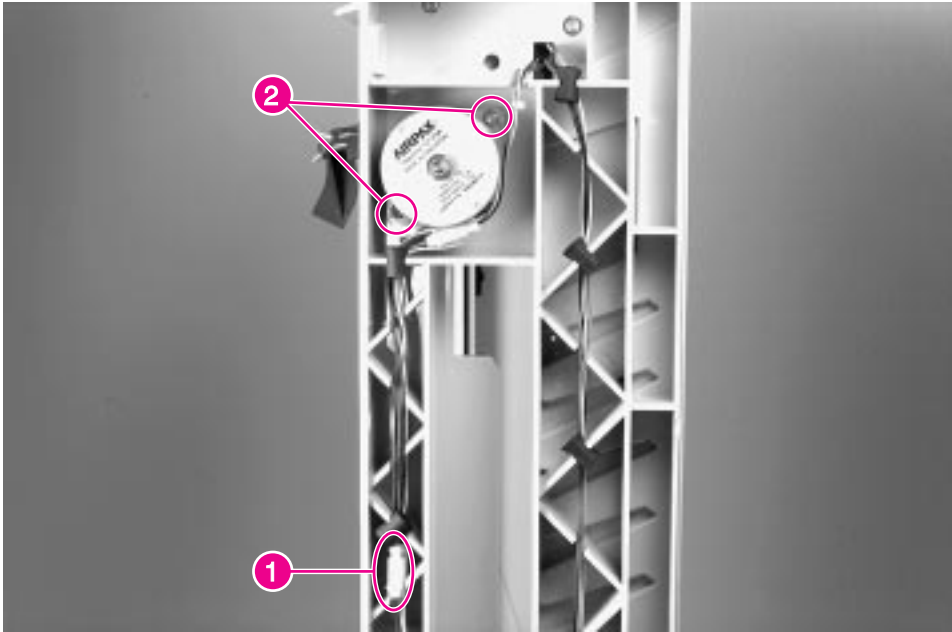

Figure 6-71 Mailbox with Stapler, Delivery Head Motor

- 1 Remove the left cover (see figure 6-54 on page 223).
- 2 Unplug the cable connector (figure 6-71, callout 1).
- 3 Remove 2 screws (figure 6-71, callout 2), slide the motor downward to release it from the frame, and lift it straight out of the frame.

To Reinstall:

Make sure that the motor is positioned in the frame with the cable grommets facing down. Make sure that the motor cable connector is plugged into the correct mating connector.

Motor, Transport Belt and Encoder Assembly

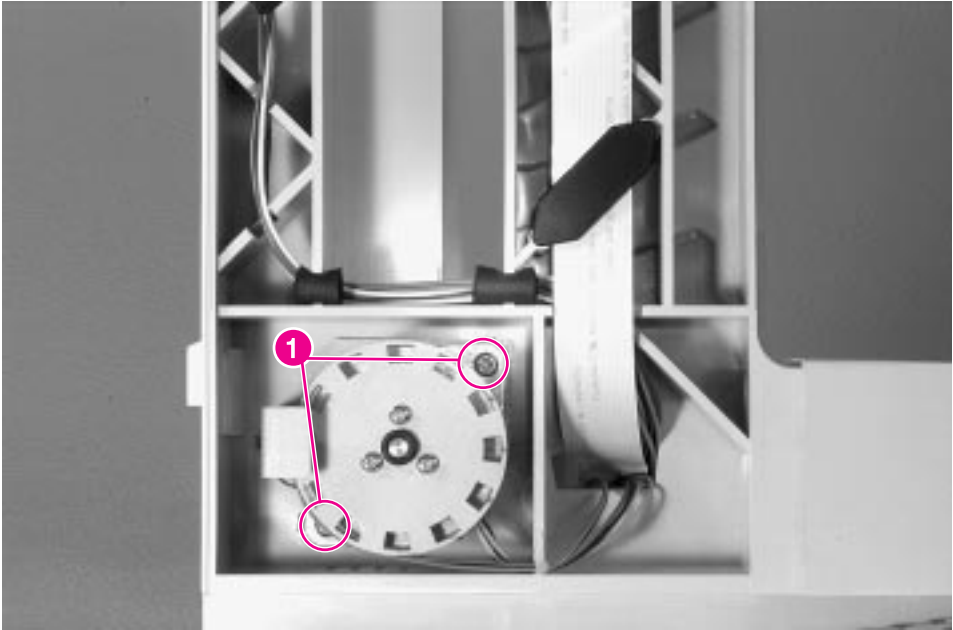

Figure 6-72 Mailbox with Stapler, Transport Belt Motor Screws

- 1 Remove the left cover (see figure 6-54 on page 223).
- 2 Remove all paper bins and the blind cover (see figure 6-75 on page 244).
- 3 Remove the Controller PCA (see figure 6-76 on page 245).
- 4 Remove 2 screws from the motor assembly (figure 6-72, callout 1).

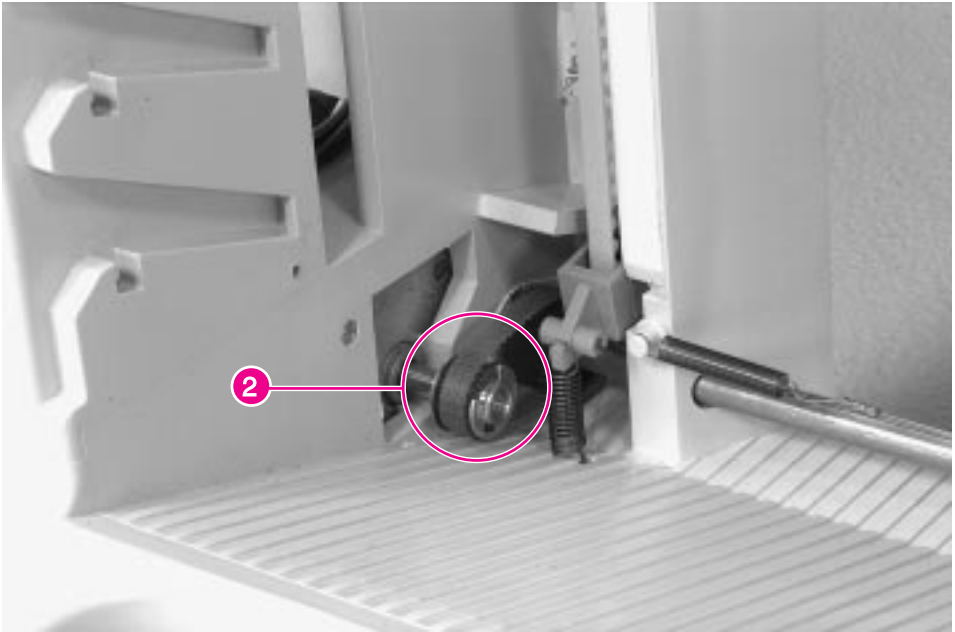

Figure 6-73 Mailbox with Stapler, Transport Belt Drive Gear

- 5 Remove the small drive belt (figure 6-73 on page 242, callout 2) from the motor drive gear.
- 6 Pull the motor and Encoder Assembly clear of the frame while guiding the cables through the access hole in the bottom of the frame.

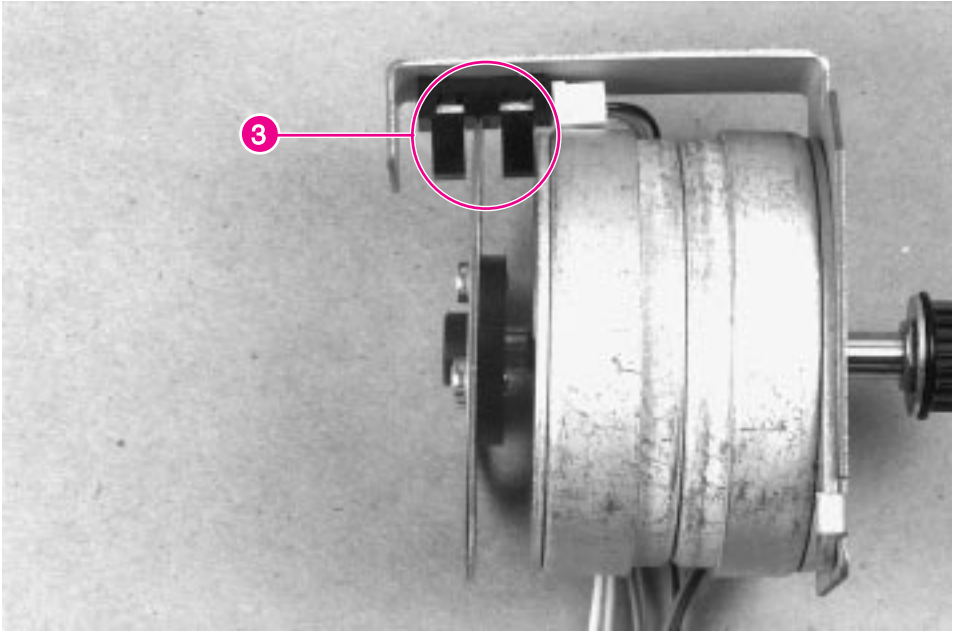

Figure 6-74 Mailbox with Stapler, Transport Belt Encoder

To Reinstall:

- 1 Make sure that the segmented disk at the back of the Transport Belt Motor is approximately centered in the Encoder Assembly photosensor (figure 6-74 on page 243, callout 3).
- 2 Replace the drive belt on the motor drive gear before installing and tightening the screws.

Paper Bins and Blind Cover

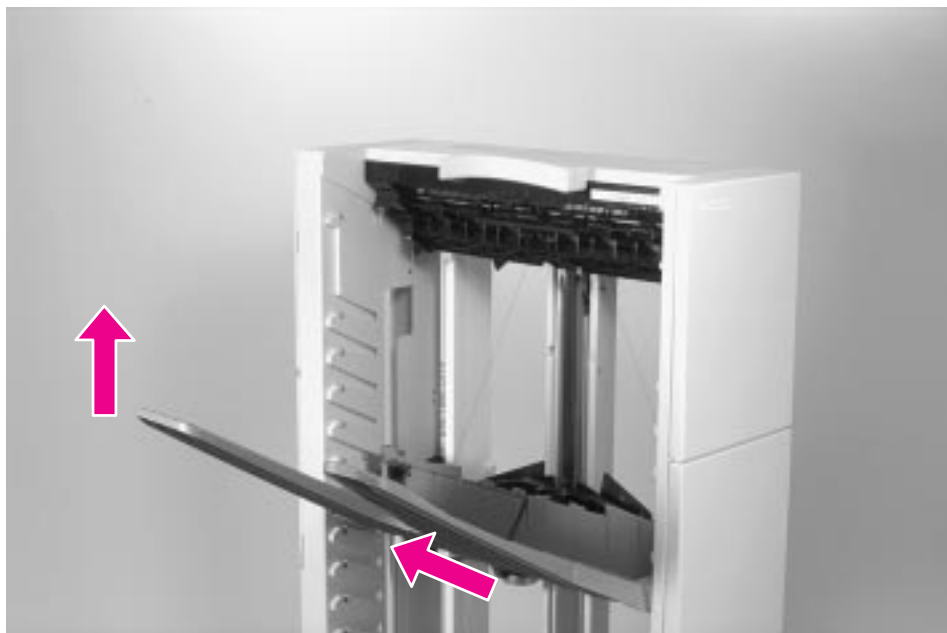

Figure 6-75 Mailbox with Stapler, Bin Removal

The procedure for removing the paper bins and the blind cover is the same. Each bin rests in its labeled slot.

- 1 Remove the paper bins and the blind cover from the top down.
- 2 Lift up on the outer edge of the bin (or blind cover) to clear the retaining notch, and pull it forward out of the frame (figure 6-75).

To Reinstall:

Replace the paper bins from the bottom up. Place the blind cover between Bin 1 and the Left Output Bin. Slide the bin into its designated slot and lower it into its retaining notch.

PCA, Controller

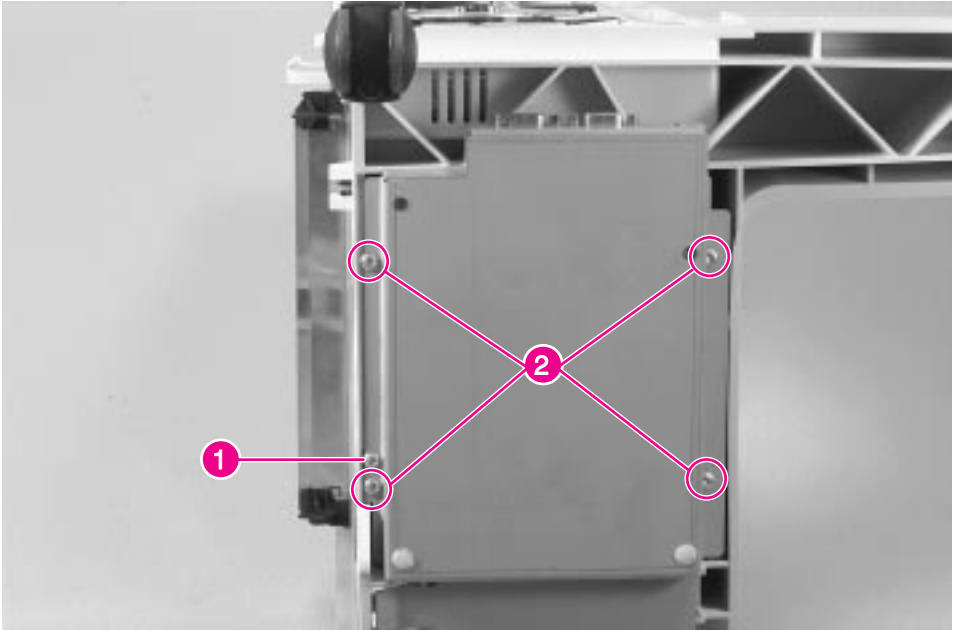

Figure 6-76 Mailbox with Stapler, PCA Removal

- 1 Remove all paper bins and the blind cover (see figure 6-75).
- 2 Lay the Multibin Mailbox/5-bin Mailbox with Stapler over onto its right side.
- 3 Remove 1 grounding screw (figure 6-76, callout 1) and 4 self-tapping screws (figure 6-76, callout 2).
- 4 Unplug all of the connectors from the PCA.
- 5 Remove the PCA from its metallic box.

Strings, Anti-Curl

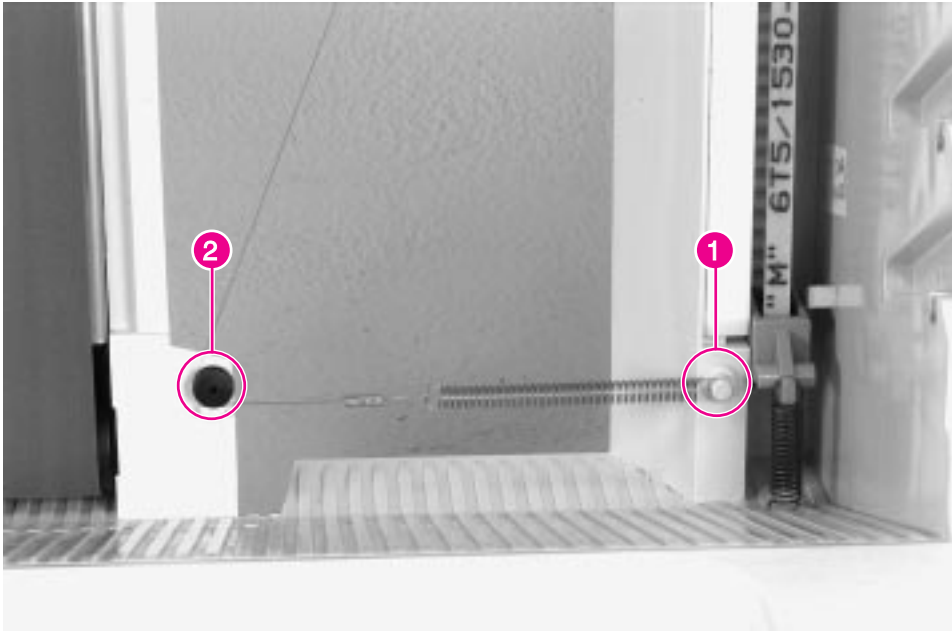

Figure 6-77 Mailbox with Stapler, Anti-Curl String Lower Connection

The Anti-Curl Strings are attached to the Jam Access Door Assembly at the top of the frame, routed through small pulleys at the back of the Delivery Head Assembly, and then routed around pulleys near the bottom of the frame where they are attached to tension springs.

- 1 Remove all paper bins and the blind cover (see figure 6-75 on page 244).
- 2 Disconnect the Anti-Curl String tension springs at the bottom of the frame (figure 6-77, callout 1), and remove the strings from the lower pulleys by snapping them free (figure 6-77, callout 2).
- 3 Remove both covers (see figure 6-54 on page 223).
- 4 Remove the Jam Access Door Assembly (see figure 6-63 on page 232 through figure 6-65 on page 234).

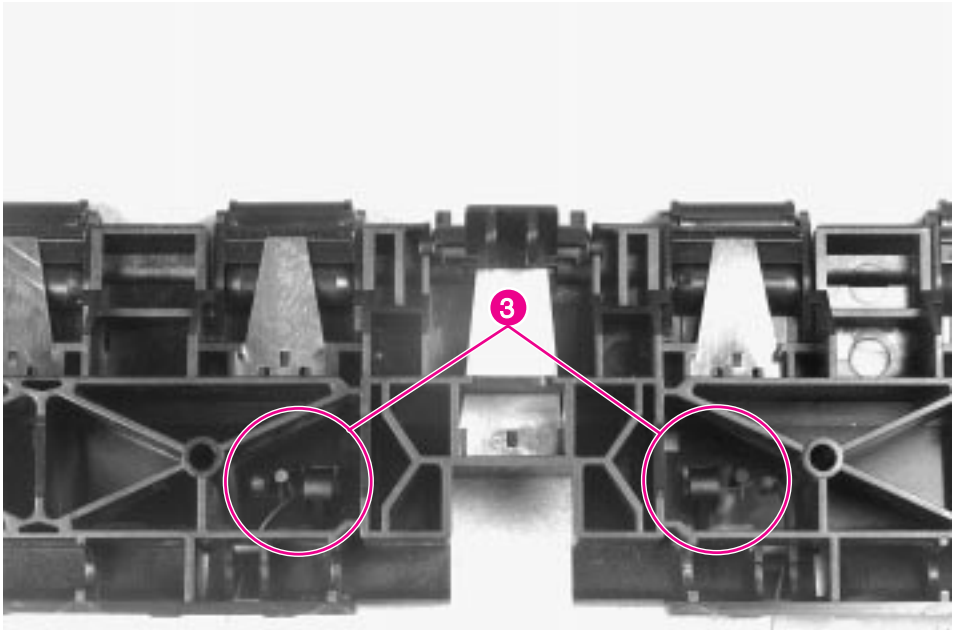

Figure 6-78 Mailbox with Stapler, Anti-Curl String Upper Connection

- 5** Disconnect the upper ends of the Anti-Curl Strings from the Jam Access Door Assembly (figure 6-78 on page 247, callout 3).
- 6** Remove the Delivery Head Assembly (see figure 6-55 on page 224 through figure 6-57 on page 226).

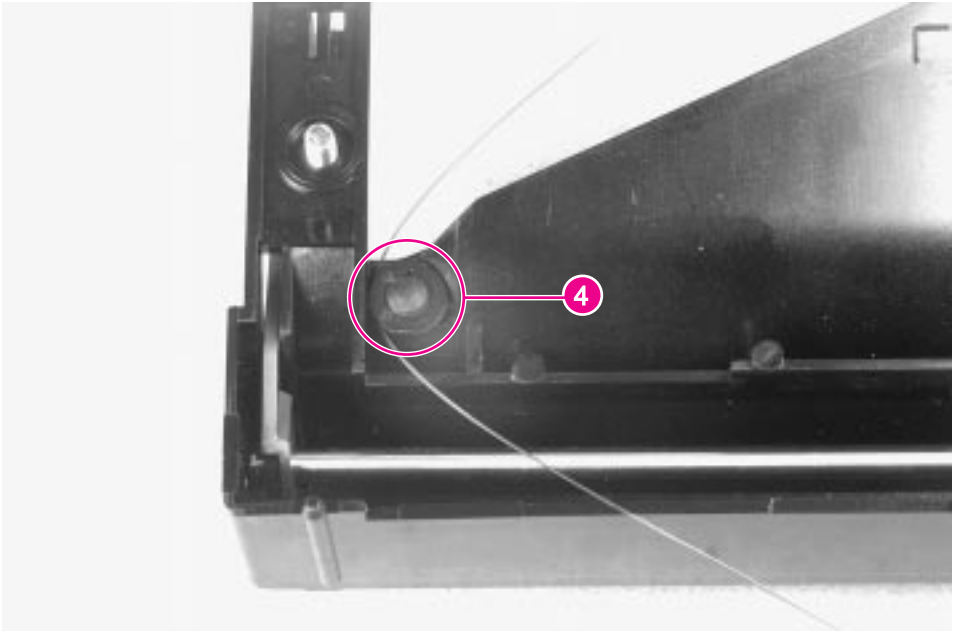

Figure 6-79 Mailbox with Stapler, Anti-Curl String Middle Connection

- 7** Remove the strings from the pulleys at the back of the Delivery Head by rotating the flat side of the pulley toward the outside of the frame (figure 6-79 on page 248, callout 4).
- 8** Remove the strings from the tension springs.

Stapler Assembly



Figure 6-80 Mailbox with Stapler, Stapler Removal

The Stapler Assembly is mounted in the 5-bin Mailbox with Stapler, replacing the three standard output bins.

- 1 Turn off the printer.
- 2 Make sure the Delivery Head Assembly is not in the stapler area. It should be in the bottom portion of the mailbox. You can move the Delivery Head Assembly downward gently with your hand.
- 3 Disconnect the cable going from the stapler to the mailbox.
- 4 Remove the Left Output Bin.
- 5 Lift up on the outer edge of the stapler to clear the retaining notches, and pull the stapler forward out of the frame (figure 6-80).

To Reinstall:

Slide the stapler into its designated slot, and lower it into its retaining notches. Replace the Left Output Bin. Connect the cable from the stapler to the mailbox. Turn the printer on.

Back Plate

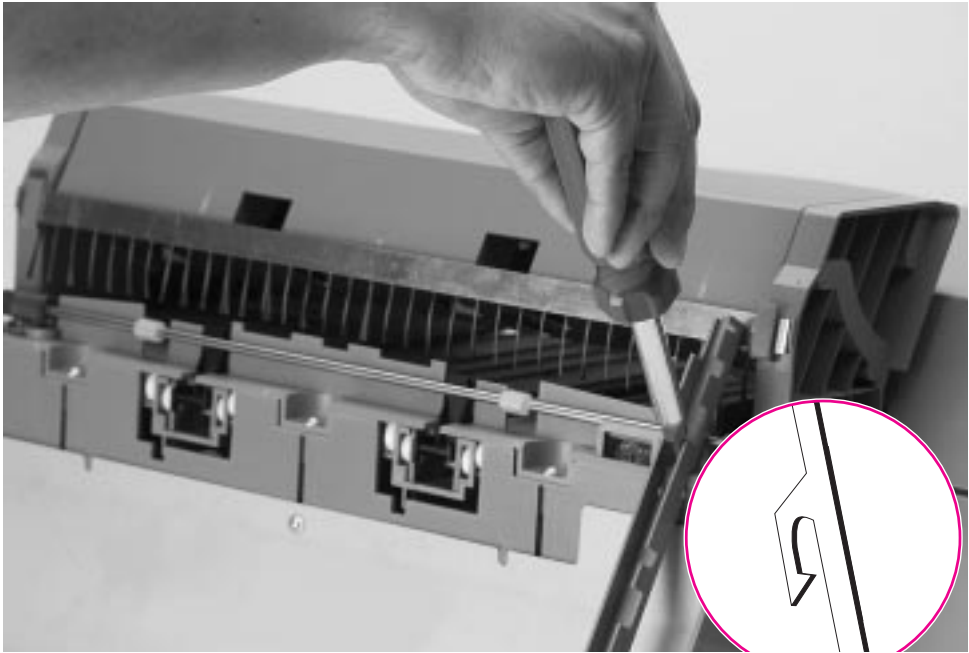

Figure 6-81 Back Plate (1 of 2)

- 1 Remove the Stapler Assembly (see figure 6-80).
- 2 Remove the Scan Bar by carefully pressing the tab on the scan bar backwards and downwards through the hole of the Stapler Bed (see figure 6-81) with a flat-tip screwdriver, then lift the bar.

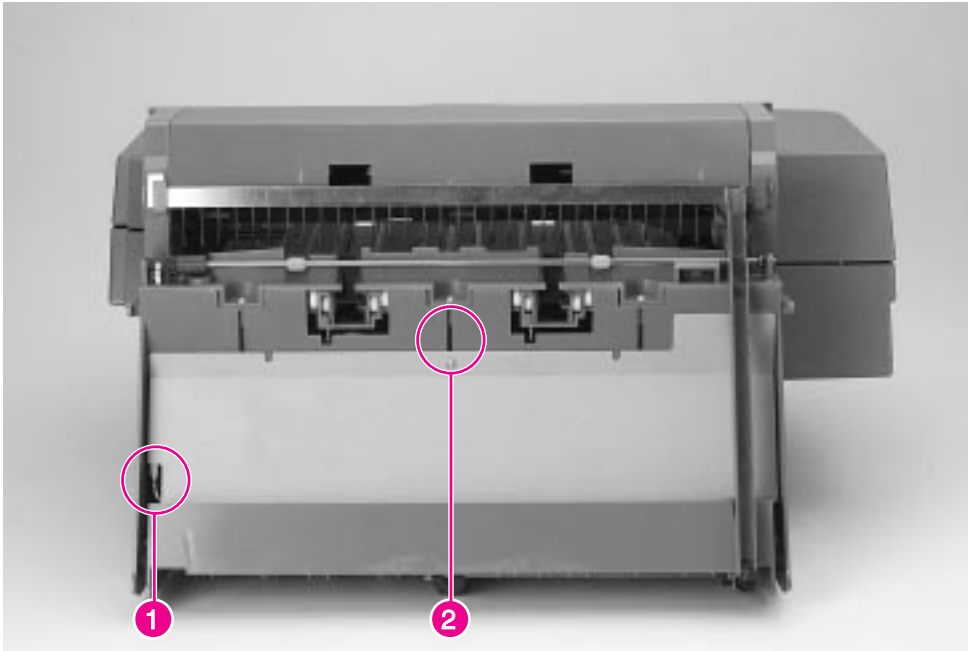

Figure 6-82 Back Plate (2 of 2)

- 3 Remove the Torx screw joining the Back Plate with the Stapler (see figure 6-82, callout 2).
- 4 Release the ground cable that is connected to the Back Plate (see figure 6-82, callout 1).

To Reinstall:

CAUTION

Keep the Top Cover Assembly open while reconnecting the cables. Cable damage could occur the next time the cover is opened if the cables are reinstalled too tightly.

Do not overtighten the screws when replacing the Back Plate.

CAUTION

Do not touch the metallic plate edges.

Stapler Controller PCA

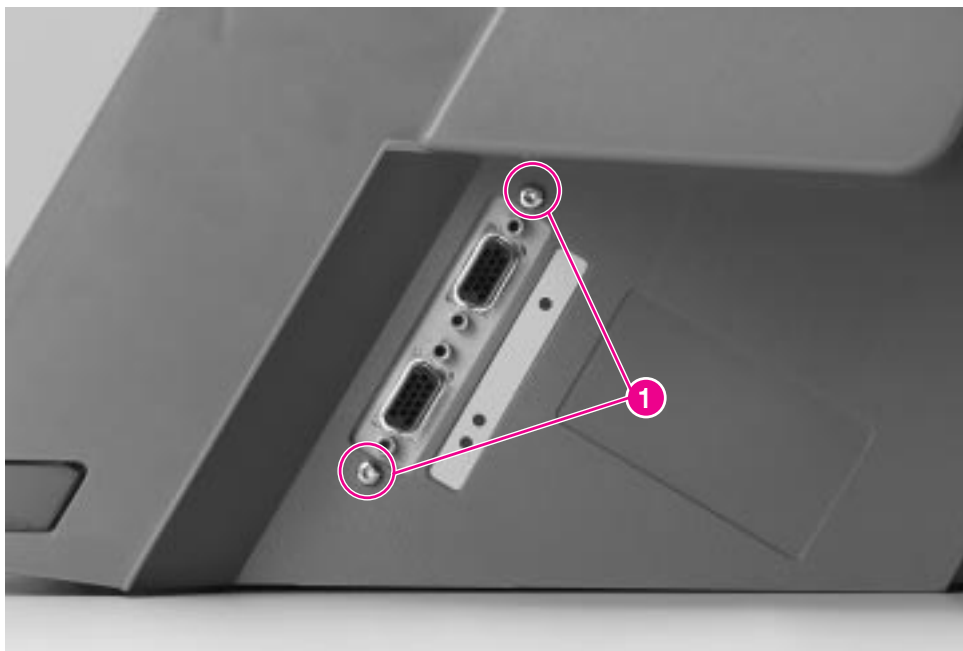

Figure 6-83 Stapler Controller PCA (1 of 3)

- 1 Remove the Stapler Assembly (see figure 6-80).
- 2 Remove the Back Plate (see figure 6-81).
- 3 Remove 2 screws located on the right side of the Stapler (see figure 6-83, callout 1).

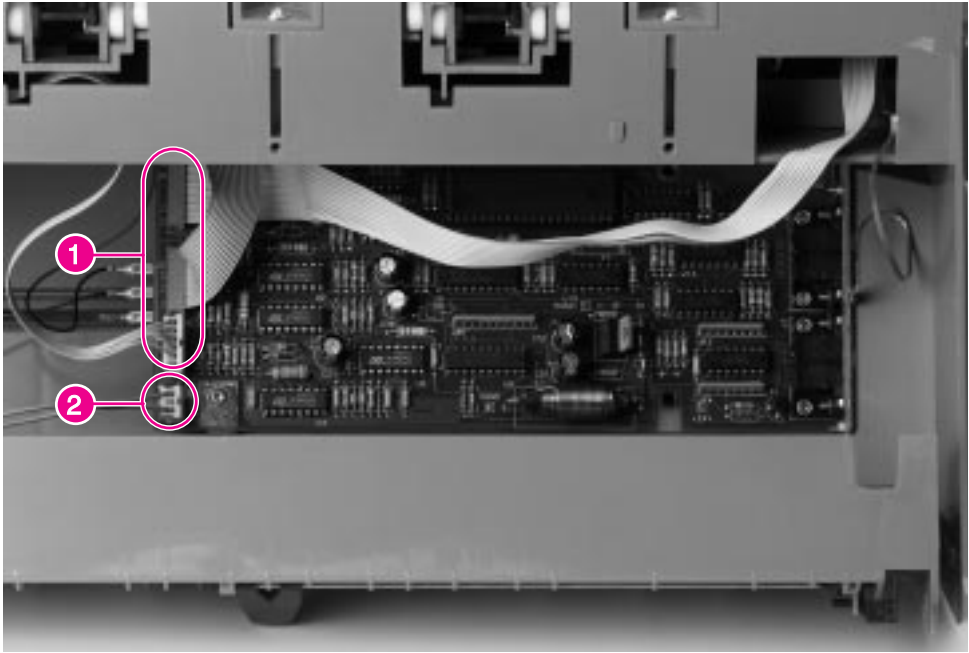

Figure 6-84 Stapler Controller PCA (2 of 3)

- 4 Unplug the cables that are connected to the PCA. Identify their color and size and the ground cables (see figure 6-84, callouts 1 and 2).

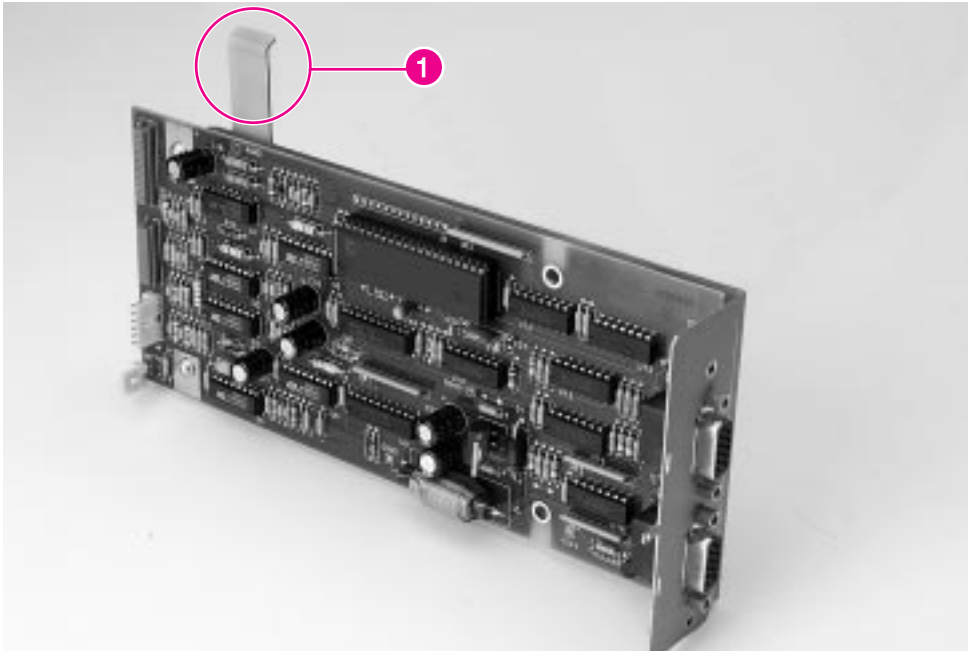

Figure 6-85 **Stapler Controller PCA (3 of 3)**

- 5 The board is supported by a hooked tab at the top of the card (see figure 6-85, callout 1). Slide the board to the left and then down.

To Reinstall:

Slide the board up and then to the right.

CAUTION

Keep the Top Cover Assembly open while reconnecting the cables. Cable damage could occur the next time the cover is opened if the cables are reinstalled too tightly.

Top Cover Assembly



Figure 6-86 Top Cover Assembly

- 1 Remove the Stapler Assembly (see figure 6-80 on page 249).
- 2 Open the Top Cover Assembly, and remove the Back Plate (see figure 6-81 on page 250).
- 3 Unplug the ground and signal cables from the right side of the Stapler Controller board, being careful to keep them in the cable holder.
- 4 On each side of the assembly, pull the hinge to release the 2 posts from the retaining notches (see figure 6-86).

To Reinstall:

CAUTION

Keep the Top Cover Assembly open while reconnecting the cables. Cable damage could occur the next time the cover is opened if the cables are reinstalled too tightly.

Stapler Bed Assembly

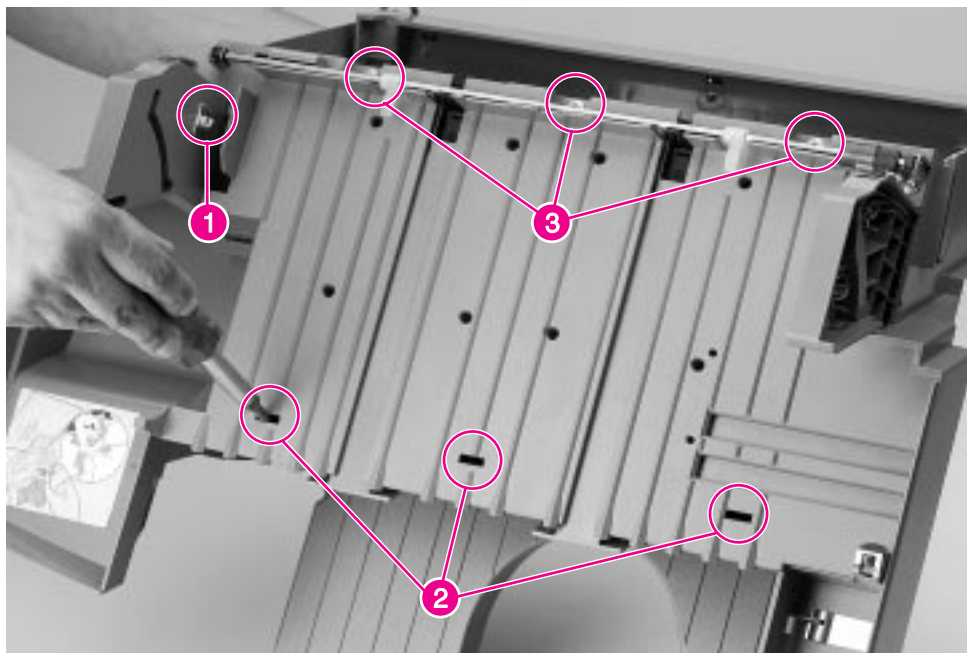

Figure 6-87 Stapler Bed Assembly

- 1 Remove the Stapler Assembly (see figure 6-80 on page 249).
- 2 Remove the Back Plate (see figure 6-81 on page 250).
- 3 Remove the Stapler Unit Controller PCA (see figure 6-87 on page 256, callout 1).
- 4 Remove the Top Cover Assembly (see figure 6-86 on page 255).
- 5 Remove the wire frame by pushing both arms of the wire frame toward the center to clear the retaining notches and lift.
- 6 Release the brushes bar from the retaining notches and lifting upwards.
- 7 Insert a flat-blade screwdriver into the top of the Stapler Bed Assembly and push gently to release the latches in the front of the stapler bed (see figure 6-87 on page 256, callout 2).
- 8 Remove 3 Torx screws that join the stapler bed with the rest of the unit (see figure 6-87 on page 256, callout 3).
- 9 To remove the Stapler Bed Assembly, lift the edge of the assembly where the stapler unit resides, then gently lift the entire Stapler Assembly.

To Reinstall:

Replace the Stapler Bed. Replace the Stapler Controller. Replace the actuator for the paper bin empty sensor.

CAUTION

Make sure that the actuator is in its proper place before replacing the Stapler Bed Assembly (see figure 6-88 on page 258, callout 3).

Hinges

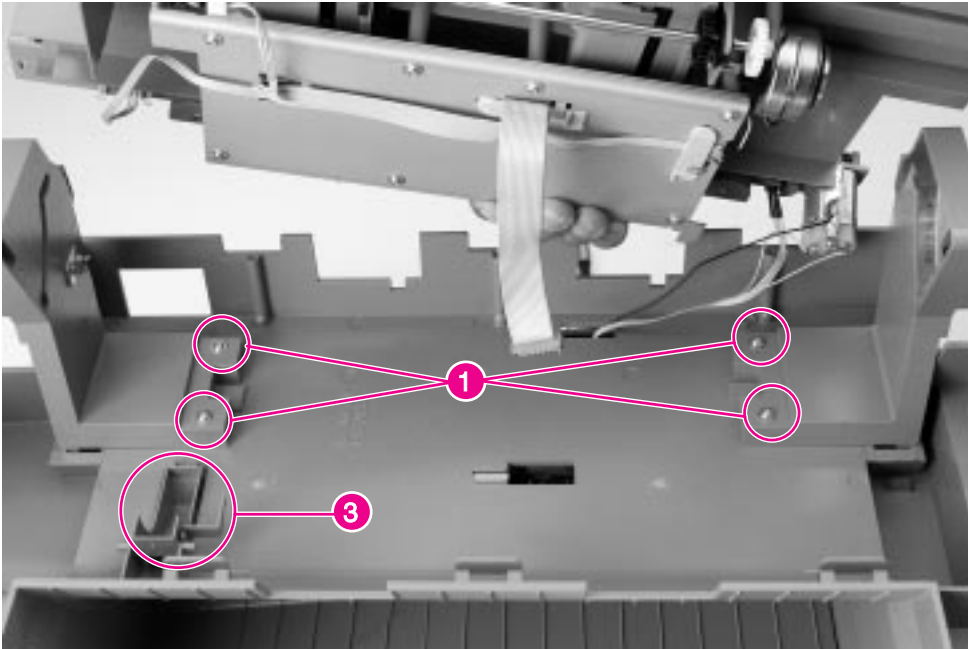

Figure 6-88 Hinges

- 1 Remove the Stapler Assembly (see figure 6-80 on page 249).
- 2 Remove the Top Cover Assembly (see figure 6-86 on page 255).
- 3 Remove the Stapler Bed Assembly (see figure 6-87 on page 256).
- 4 Release the brushes bar from the retaining notches, and lift upwards.
- 5 Remove 2 screws joining each hinge to the housing (see figure 6-88, callout 1).
- 6 Disconnect the 2 cables in the hinge containing cables from the Stapler Controller PCA (see figure 6-84 on page 253, callout 2).

7-bin Tabletop Mailbox

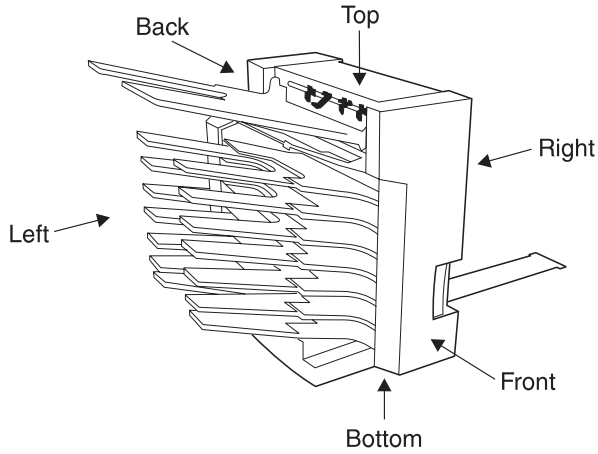

Figure 6-89 Orientation of the 7-bin Tabletop Mailbox

Note

Before you begin any removal or replacement procedure, turn off all equipment and unplug the mailbox power supply cable.

7-bin Tabletop Mailbox Front Cover

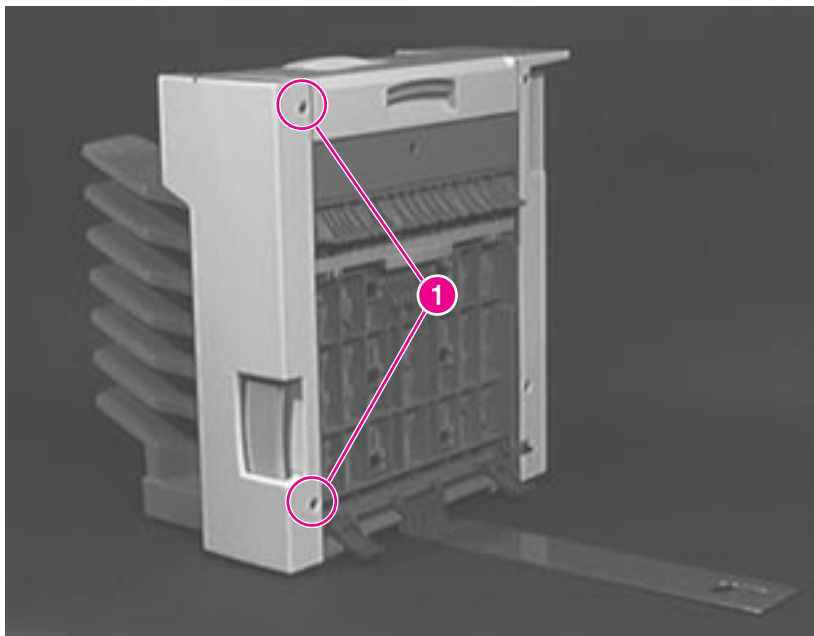

Figure 6-90 Front cover (1 of 3)

- 1 Remove 2 screws (callout 1).

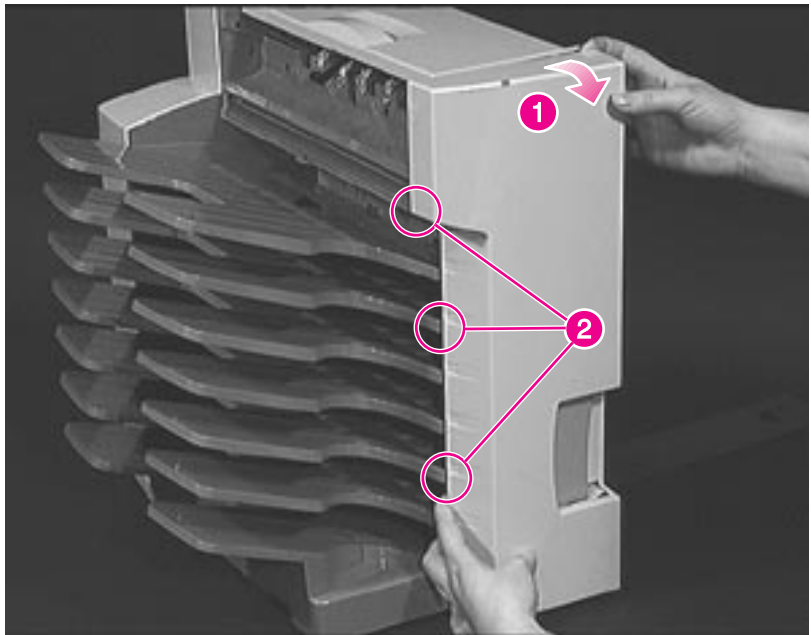

Figure 6-91 Front cover (2 of 3)

- 2 Loosen the right side of the Front Cover and pull it toward you approximately 0.5 inch (1.5 centimeters) to clear the tabs (callout 1).
- 3 Release and clear the tabs on the left side of the Front Cover (callout 2).

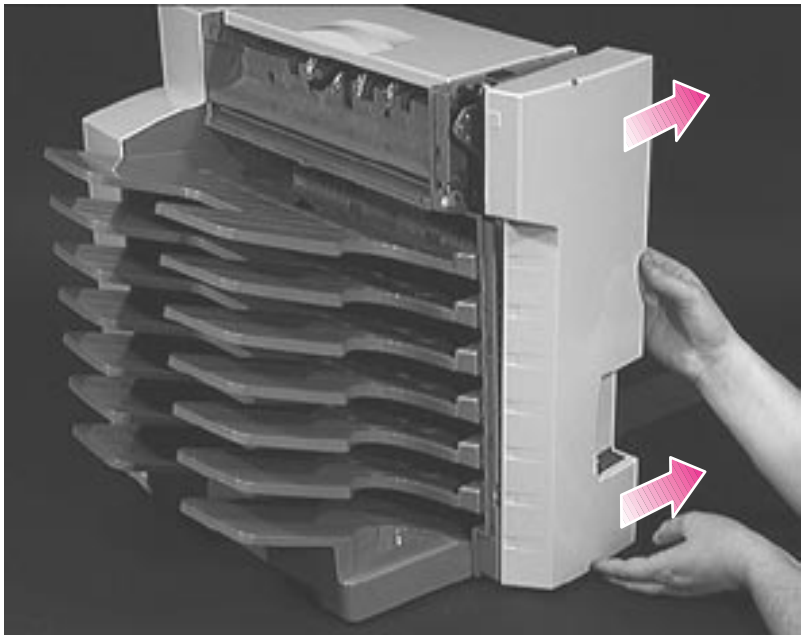

Figure 6-92 Front cover (3 of 3)

CAUTION

Be careful not to damage the handle as you remove the cover. The handle can easily catch on the cover.

- 4 To clear the handle, rotate the Front Cover to the right, and remove it as shown in figure 6-92.

7-bin Tabletop Mailbox Back Cover

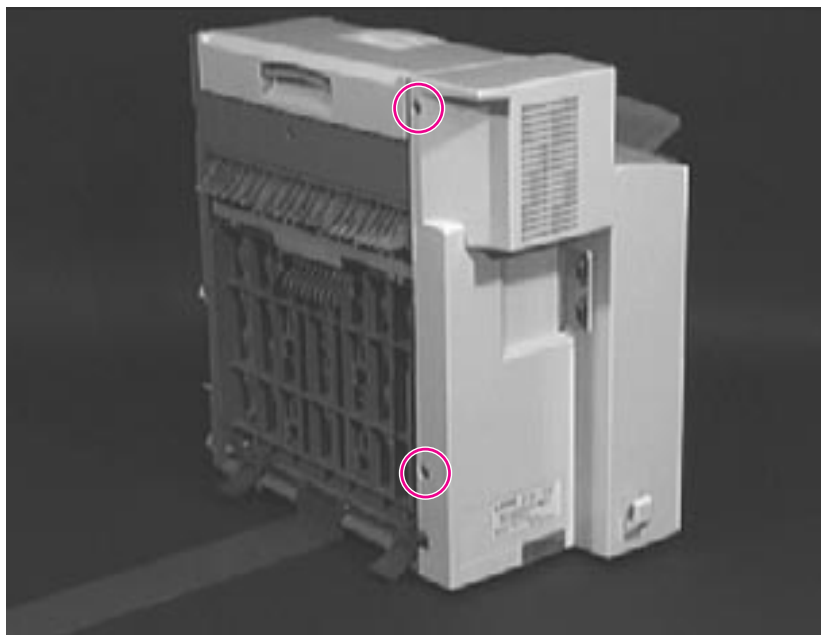

Figure 6-93 Back cover (1 of 2)

- 1 Remove 2 screws.

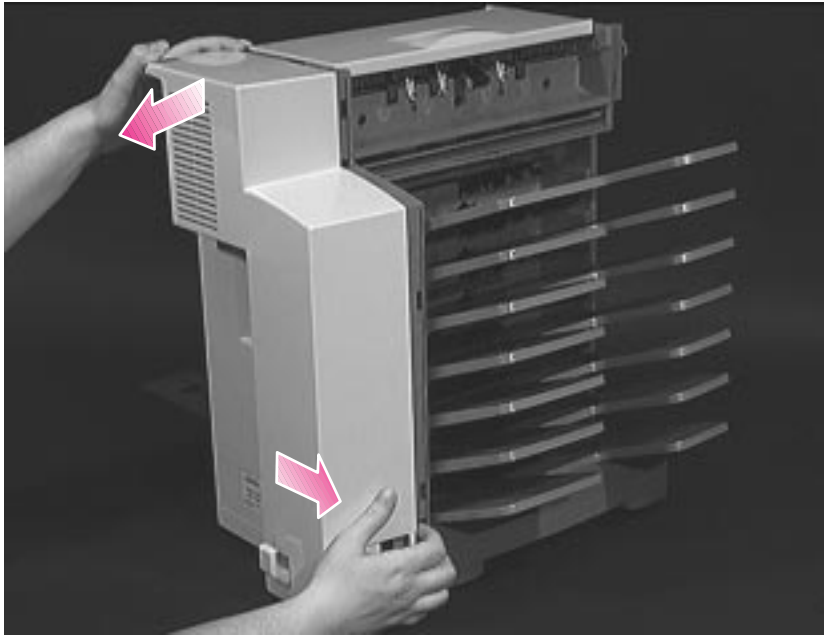

Figure 6-94 Back cover (2 of 2)

- 2 Pull the Back Cover toward you to remove it.

7-bin Tabletop Mailbox Top Cover

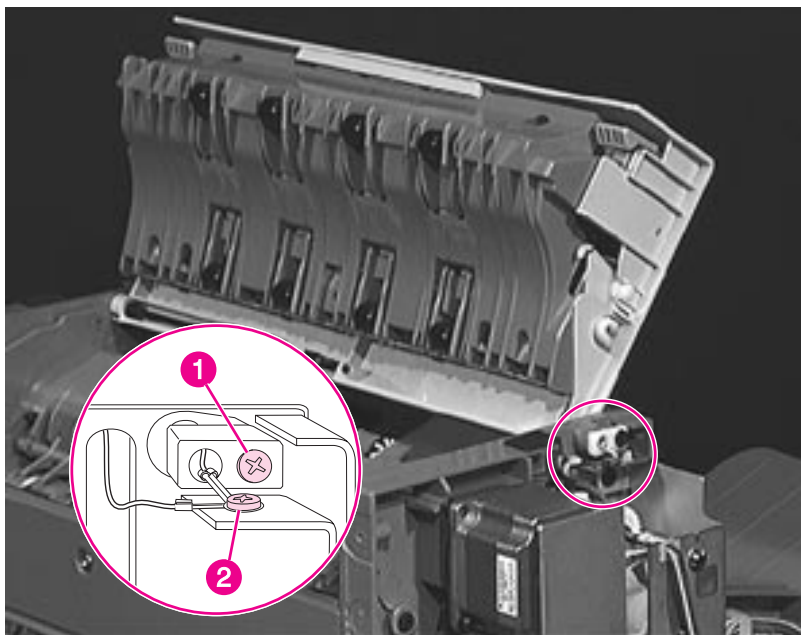

Figure 6-95 Top cover (1 of 4)

- 1 Remove the Front Cover (page 260) and the Back Cover (page 263).
- 2 Open the Top Cover, and remove the Top Cover's screw and bushing (callout 1).
- 3 Remove the grounding screw (callout 2).

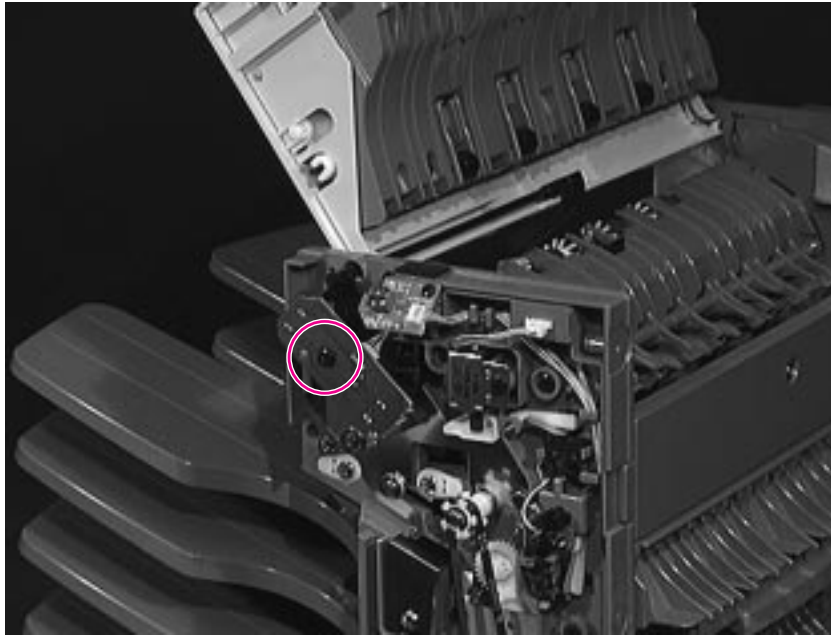

Figure 6-96 Top cover (2 of 4)

- 4 Remove the screw from the PCA.

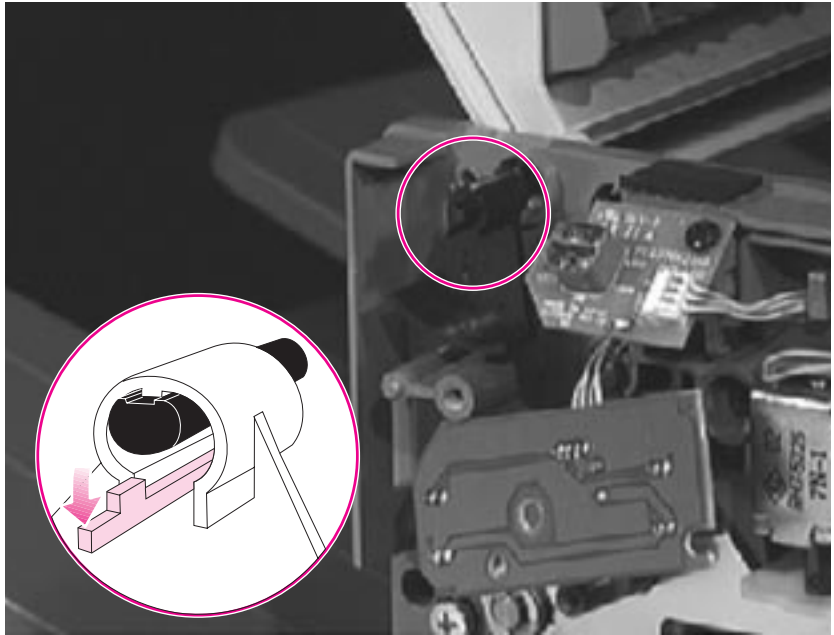

Figure 6-97 Top cover (3 of 4)

- 5 To take out the flag, bend the plastic shaft carefully as shown.

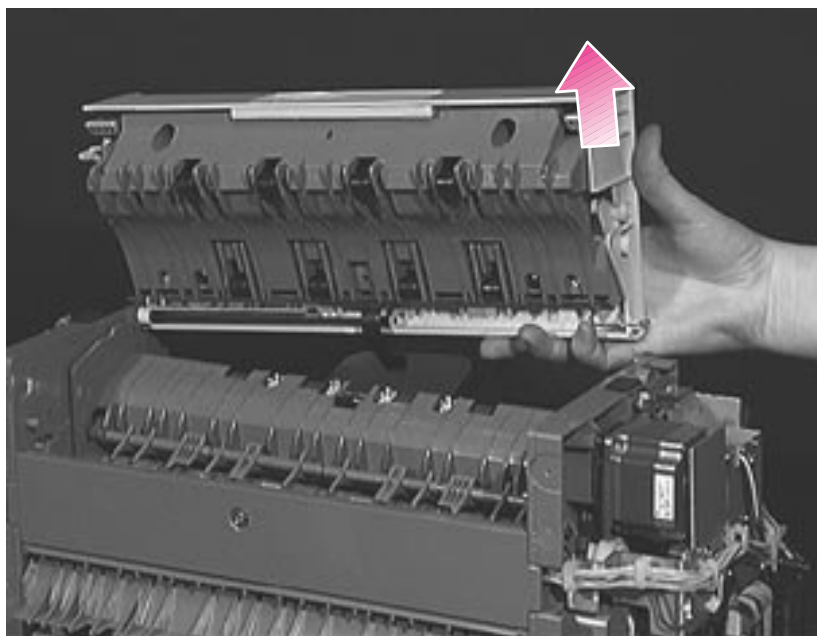

Figure 6-98 Top cover (4 of 4)

- 6 To remove the Top Cover lift the right side first as shown.

7-bin Tabletop Mailbox Controller PCA

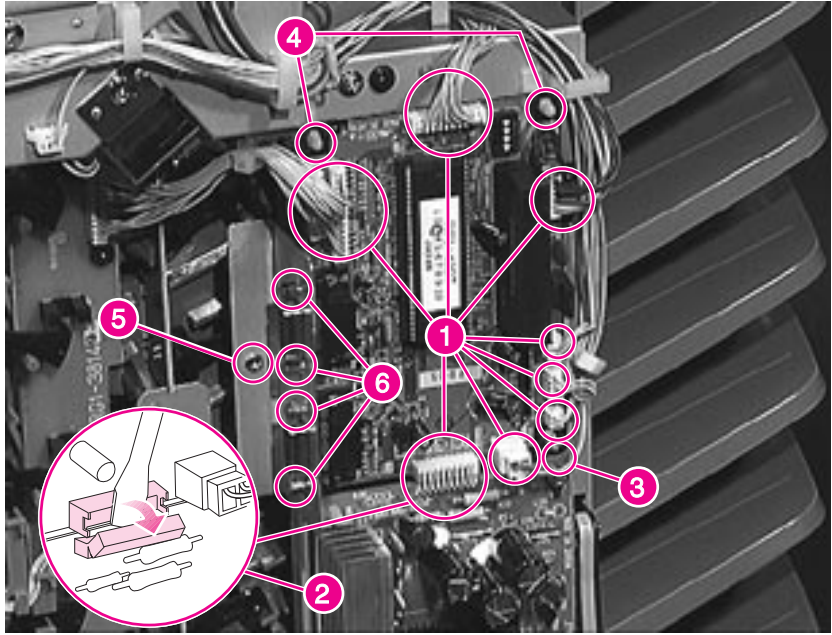

Figure 6-99

Mailbox Controller PCA

- 1 Remove the Back Cover (page 263).
- 2 Unplug 8 connectors from the Controller PCA (callout 1).
- 3 To unplug connector J202, pry it open with a flat blade screwdriver (callout 2).
- 4 Remove 1 screw from the Controller PCA below Connector J3 (callout 3).
- 5 Remove the PCA from its 2 plastic pins (callout 4).
- 6 Remove 1 screw from the plate (callout 5).
- 7 Remove 4 hex screws from the connectors on the metal plate. Remove the PCA controller (callout 6).

7-bin Tabletop Mailbox Power Supply

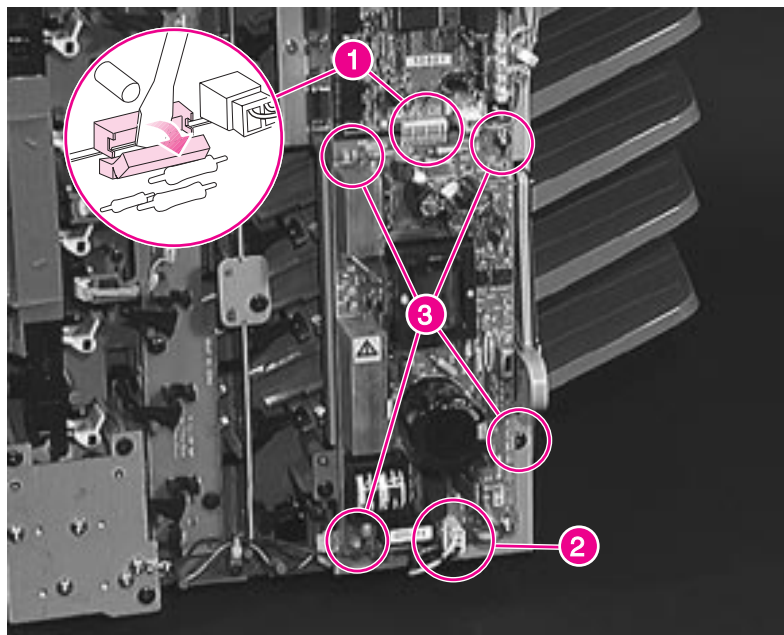

Figure 6-100 Mailbox Power Supply

- 1 Remove the Back Cover (page 263).
- 2 Pry connector J202 open with a flat blade screwdriver, and unplug it (callout 1).
- 3 At the bottom of the power supply, unplug J201 (callout 2).
- 4 Remove 2 screws, and pull the power supply off its 2 pins (callout 3).

Note

Be sure to replace all the Power Supply Connectors.

7-bin Tabletop Mailbox Right Door Assembly (Paper Path Cover)

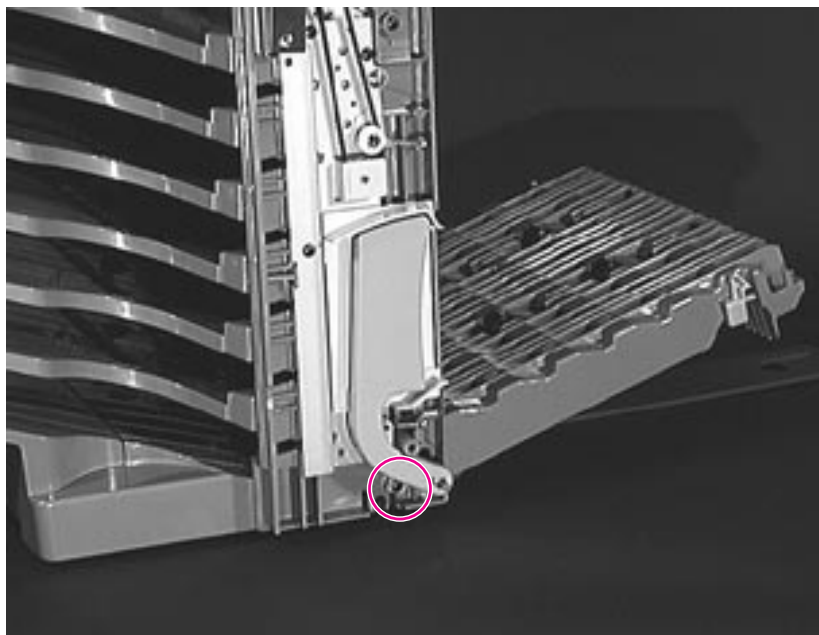

Figure 6-101 Right Door Assembly (Paper Path Cover) (1 of 4)

- 1 Remove the Front Cover (page 260) and the Back Cover (page 263).
- 2 Remove 1 screw from the front side and the bushing below the handle.

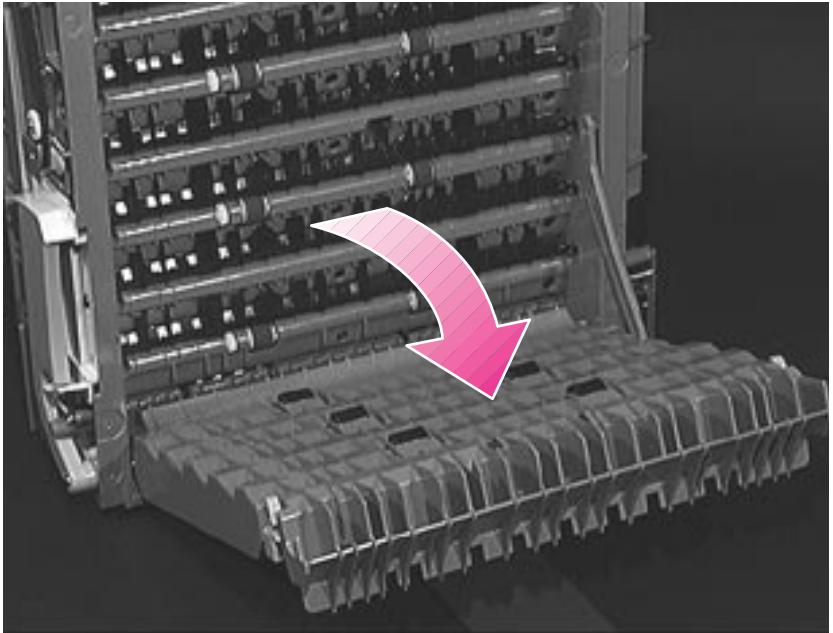

Figure 6-102 Right Door Assembly (Paper Path Cover) (2 of 4)

- 3 Open the right door assembly (paper path cover).

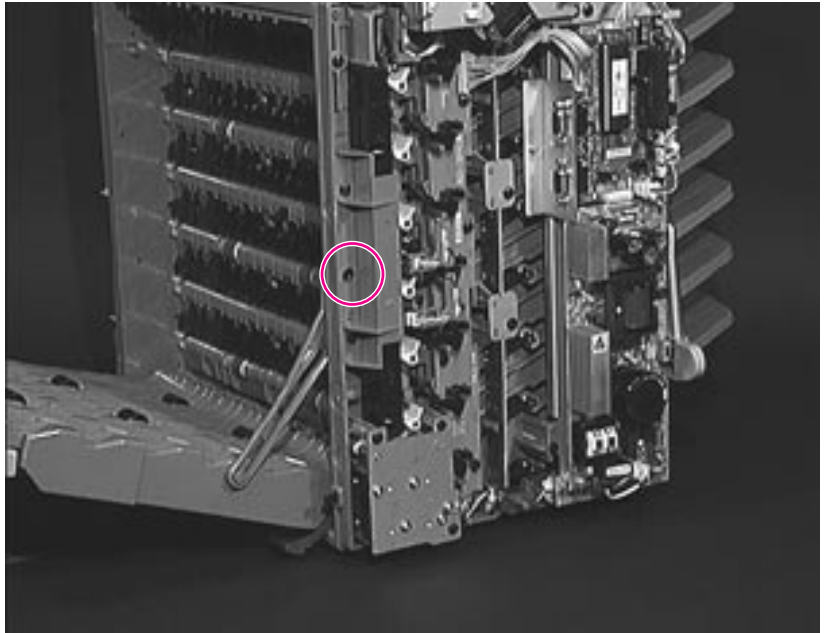

Figure 6-103 Right Door Assembly (Paper Path Cover) (3 of 4)

- 4 Remove the holding arm's screw, and release the Right Door Assembly.

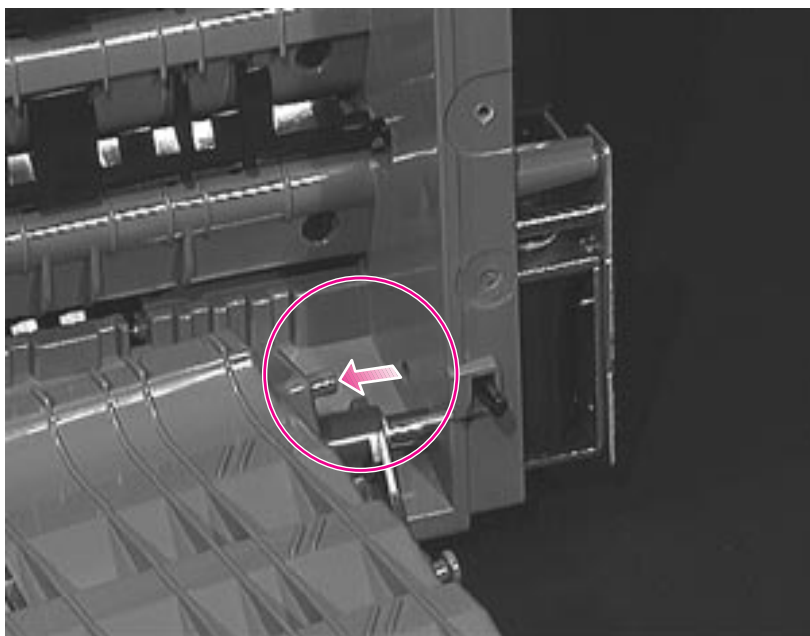

Figure 6-104 Right Door Assembly (Paper Path Cover) (4 of 4)

- 5 Release the plastic pin on the right end, and remove the paper path cover as shown in figure 6-104.

7-bin Tabletop Mailbox Face Down Bins

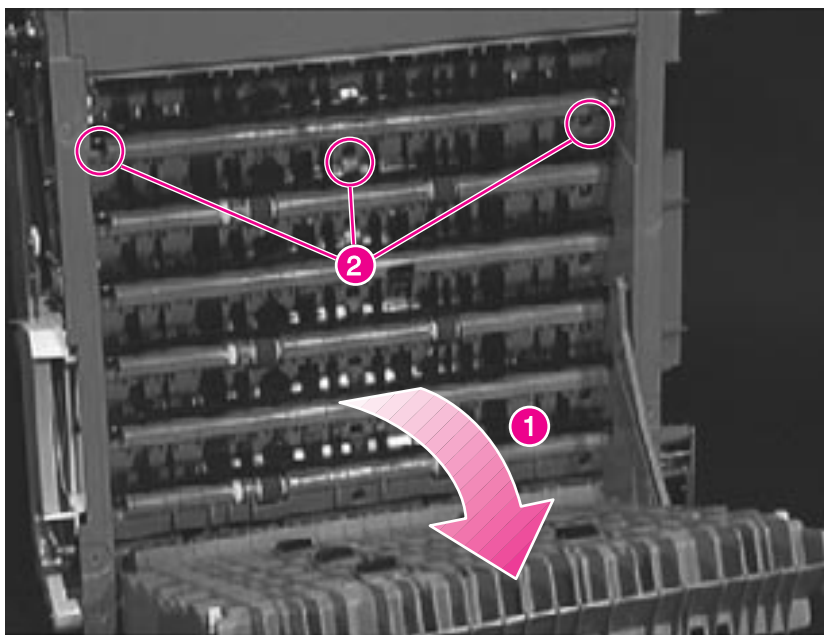

Figure 6-105 Face Down Bins (1 of 3)

Note

Bins 1, 3, and 5 each have one rear roller. Bins 2, 4, and 6 each have 2 rear rollers. The procedure for removing and replacing each of the bins is the same.

- 1 Remove the Front Cover (page 260) and the Back Cover (page 263).
- 2 Open the right door assembly (paper path cover) (callout 1).
- 3 Remove 3 screws at the right (engine) side of the unit from the bin that needs to be replaced (callout 2).

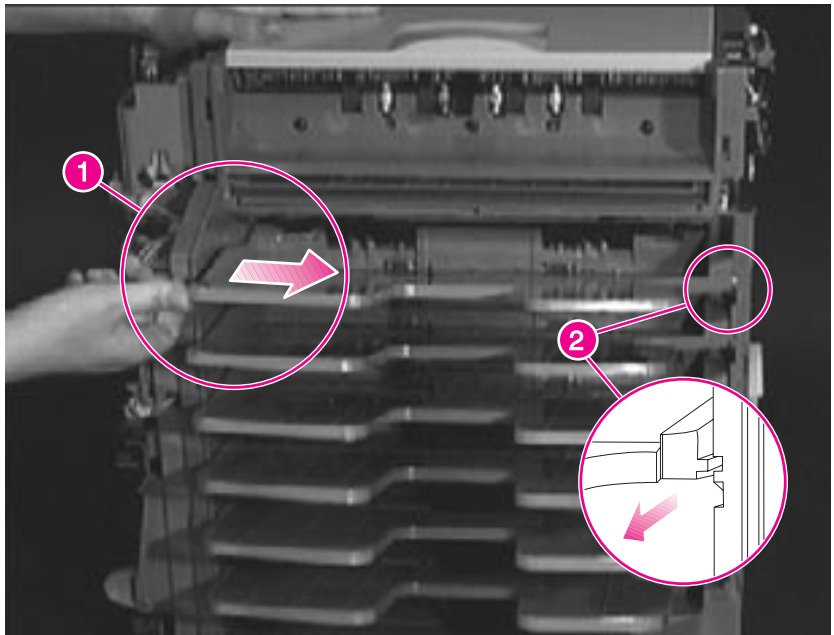

Figure 6-106 Face Down Bins (2 of 3)

- 4 Push the bin to the right until it releases (callout 1). Next pull it straight out as shown. Note the position of the 2 tabs (callout 2).

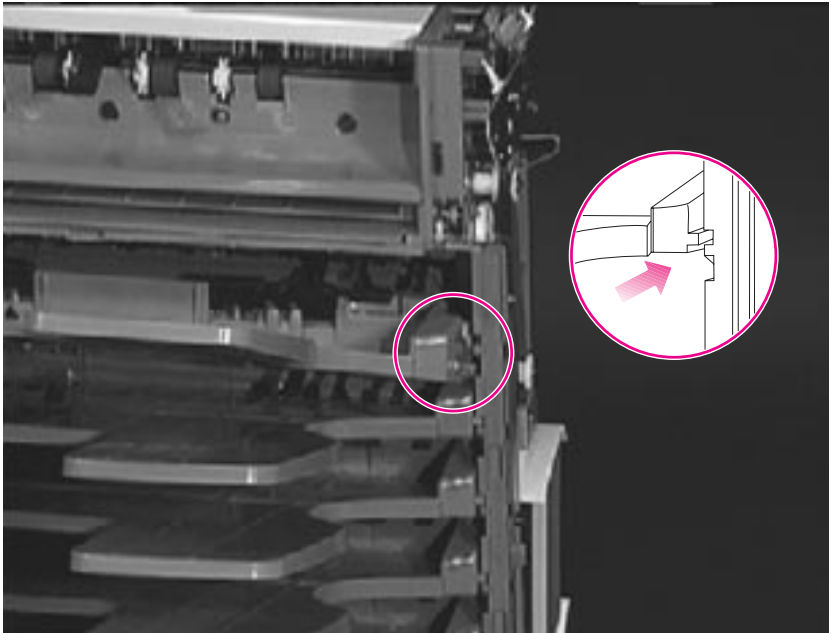

Figure 6-107 Face Down Bins (3 of 3)

To Reinstall:

- 1 Guide the empty bin sensor and the gear of the tray into place as shown.
- 2 Make sure that the holes for the 3 screws align with the holes of the tray.

7-bin Tabletop Mailbox Empty Bin Sensor PCA



Figure 6-108 Empty Bin Sensor PCA (1 of 2)

- 1 Remove the Back Cover (page 263).
- 2 Unplug J305 (the topmost connector) from the Empty Bin Sensor PCA (callout 1).
- 3 Remove 2 screws and the metal plates that hold the Empty Bin Sensor PCA (callout 2).

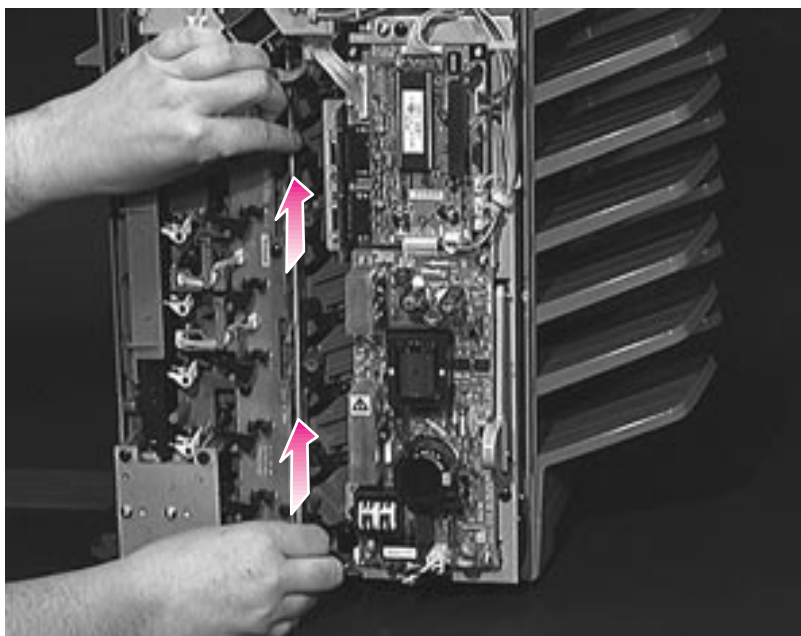

Figure 6-109 Empty Bin Sensor PCA (2 of 2)

- 4 Lift up the Empty Bin Sensor PCA to free it from the sensor flags, and pull it out as shown.

7-bin Tabletop Mailbox Full Bin and Interlock Sensor PCA

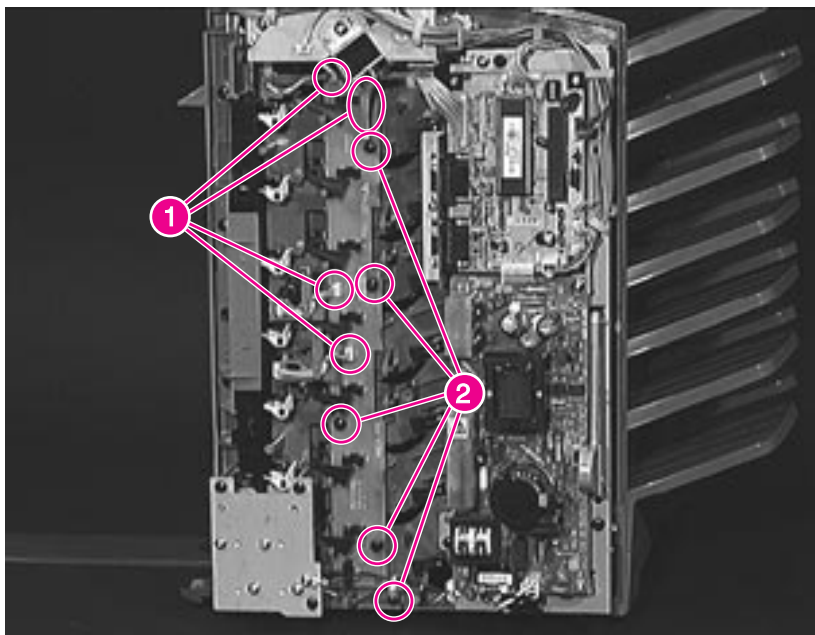

Figure 6-110 Full Bin and Interlock Sensor PCA (1 of 2)

- 1 Remove the Back Cover (page 263) and the Empty Bin Sensor PCA (page 278).
- 2 Unplug J301, J302, J303, and J304 (callout 1).
- 3 Remove 4 screws from the PCA and the screw in the harness (callout 2).

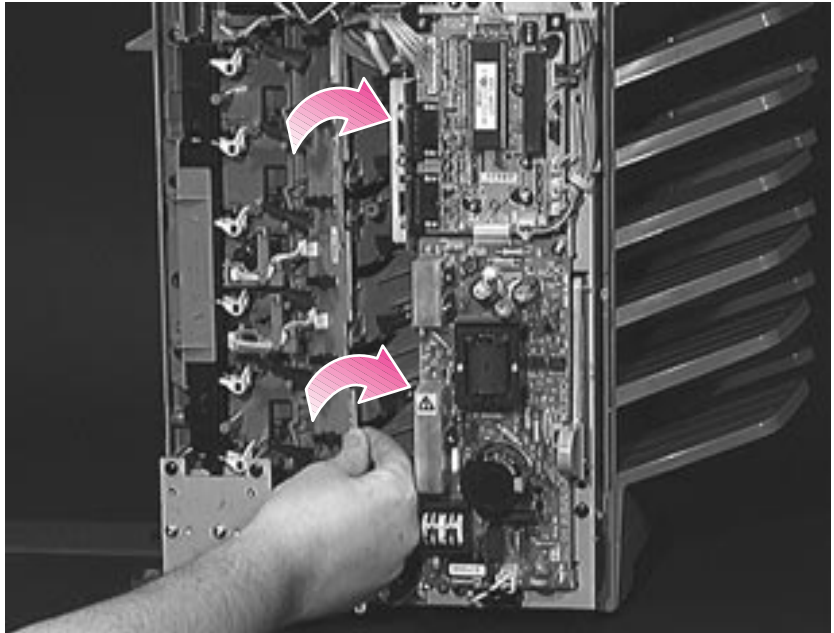

Figure 6-111 Full Bin and Interlock Sensor PCA (2 of 2)

- 4 Rotate the PCA toward the right, and then pull it out as shown.

7-bin Tabletop Mailbox LED PCA

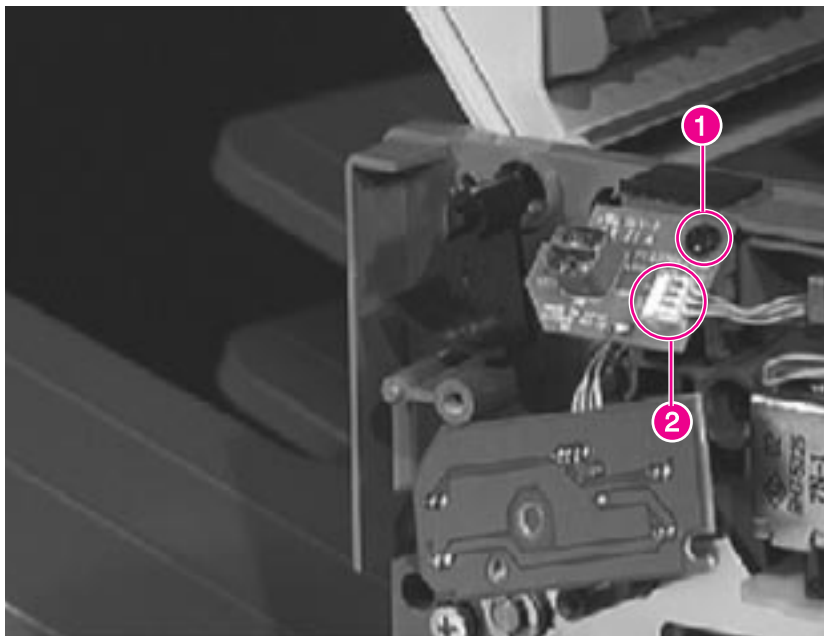

Figure 6-112 LED PCA

- 1 Remove the Front Cover (page 260).
- 2 Remove 1 screw (callout 1).
- 3 Unplug J307 from the LED PCA, and remove the LED PCA (callout 2).

7-bin Tabletop Mailbox Face Up Sensors PCA

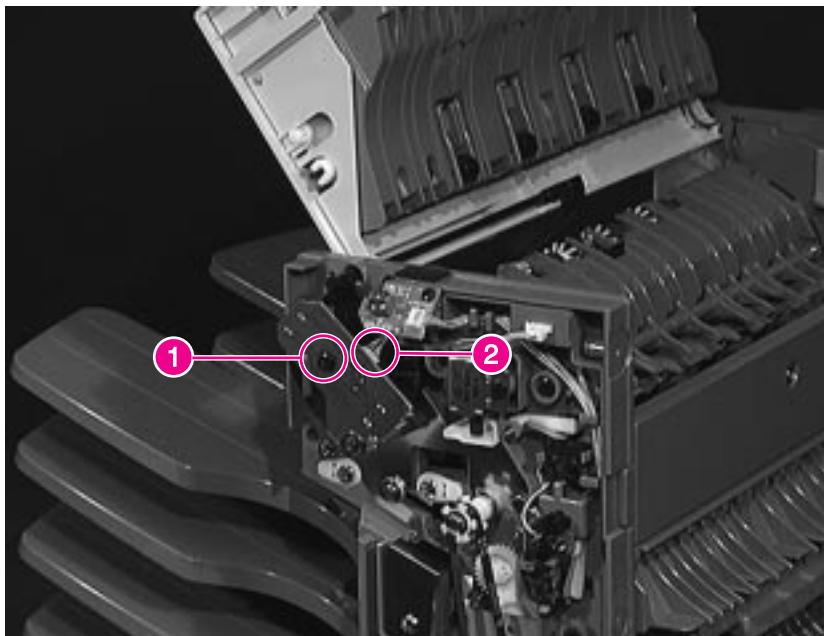

Figure 6-113 Face Up Sensors PCA

- 1 Remove the Front Cover (page 260).
- 2 Remove 1 screw (callout 1).
- 3 Unplug J306 from the Empty Bin Sensor PCA, and remove the Empty Bin Sensor PCA (callout 2).

7-bin Tabletop Mailbox Reversing Mechanism Motor

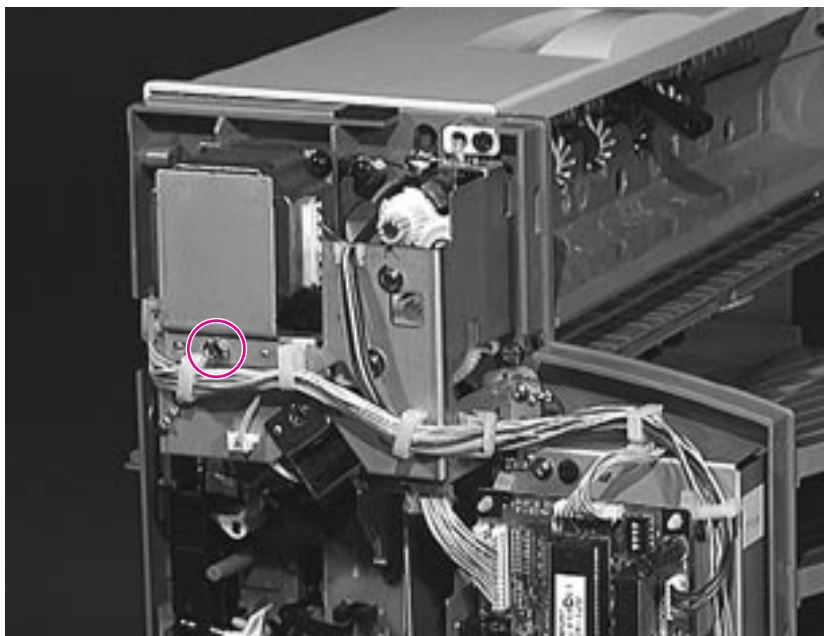

Figure 6-114 Reversing Mechanism Motor (1 of 2)

- 1 Remove the Back Cover (page 263).
- 2 Remove 1 screw from the metal plate.

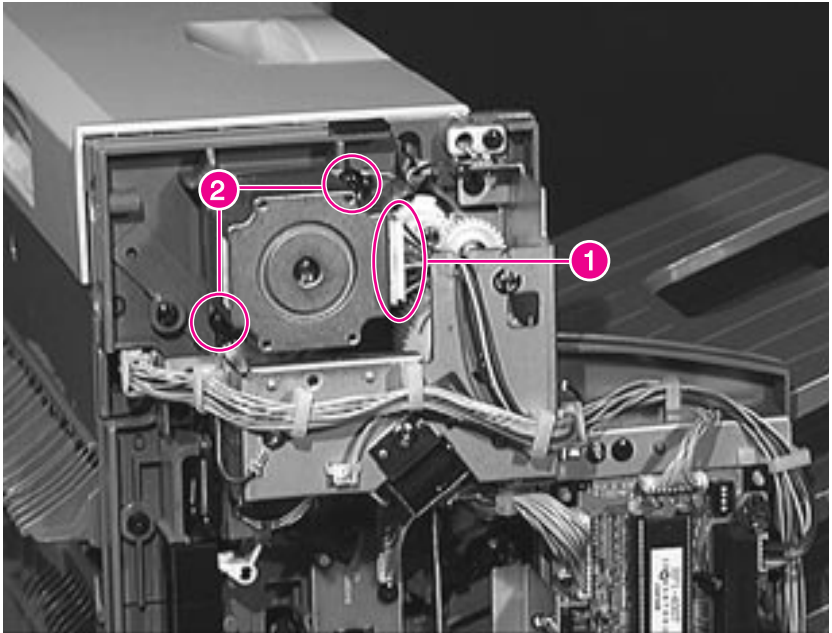

Figure 6-115 Reversing Mechanism Motor (2 of 2)

- 3 Unplug the motor's connector (callout 1).
- 4 Remove 2 screws (callout 2) and the motor.

CAUTION

Do not damage the belt as you remove the motor.

7-bin Tabletop Mailbox Face Up/Diverter Assembly (Flipper)

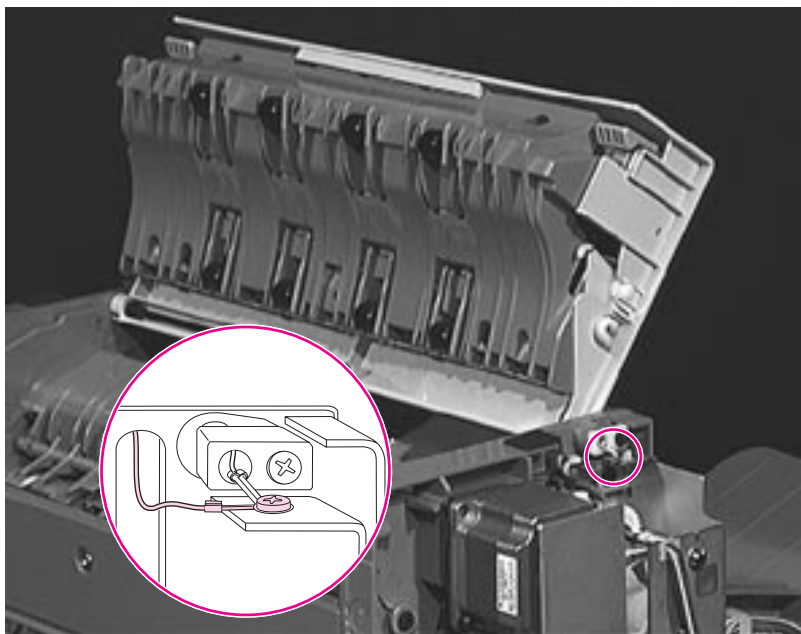

Figure 6-116 Face Up/Diverter Assembly (Flipper) (1 of 3)

- 1 Remove the Front Cover (page 260) and the Back Cover (page 263).
- 2 Open the Top Cover as shown.
- 3 Remove the grounding screw at the top back side (figure 6-116).

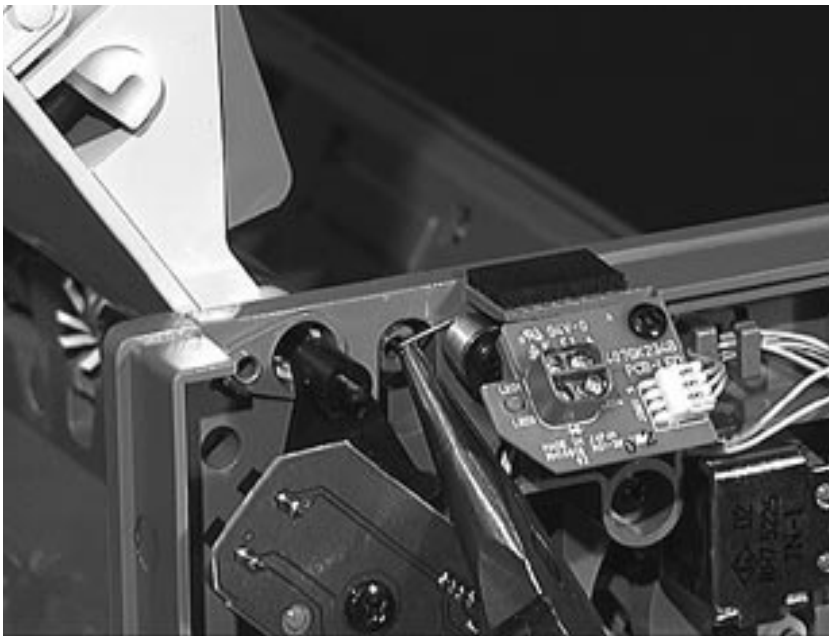
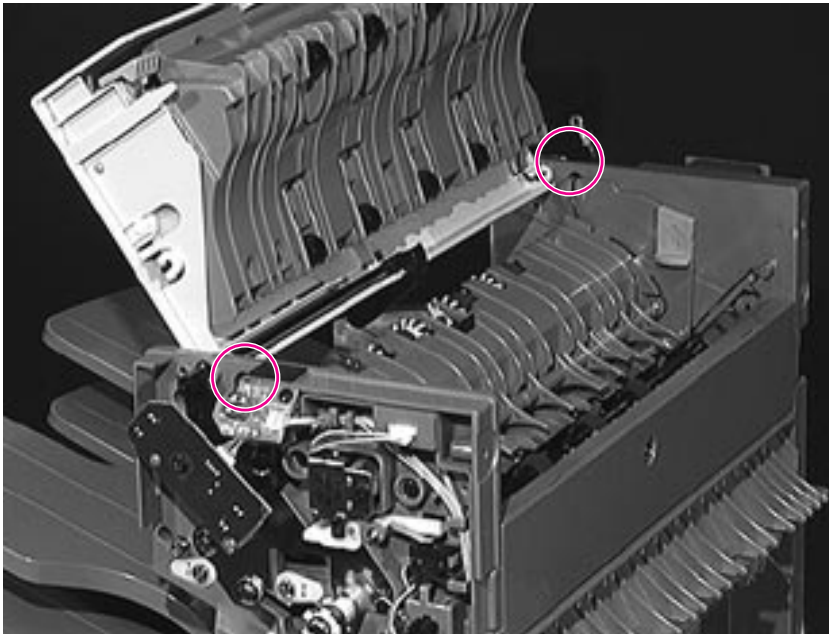

Figure 6-117 Face Up/Diverter Assembly (Flipper) (2 of 3)

- 4 Using pliers, release the springs at each end of the assembly.

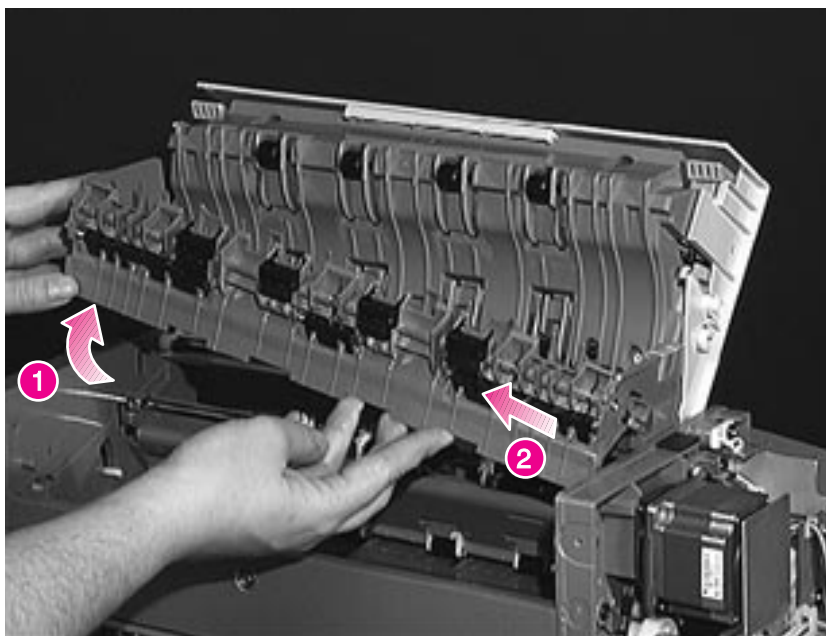

Figure 6-118 Face Up/Diverter Assembly (Flipper) (3 of 3)

- 5 Rotate the assembly upward, and then release side 1 first and side 2 second. Remove the assembly as shown.

7-bin Tabletop Mailbox Short Tray 7

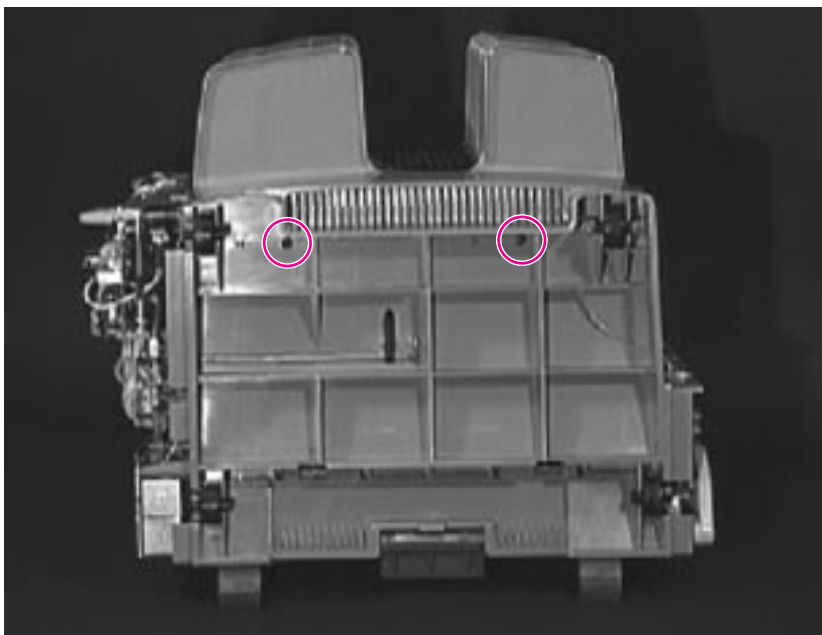

Figure 6-119 Short Tray 7

- 1 Place the 7-bin Tabletop Mailbox on its side as shown.
- 2 Remove 2 screws from the bottom of the mailbox.
- 3 Remove the tray.

7-bin Tabletop Mailbox Solenoid Reversing Mechanism

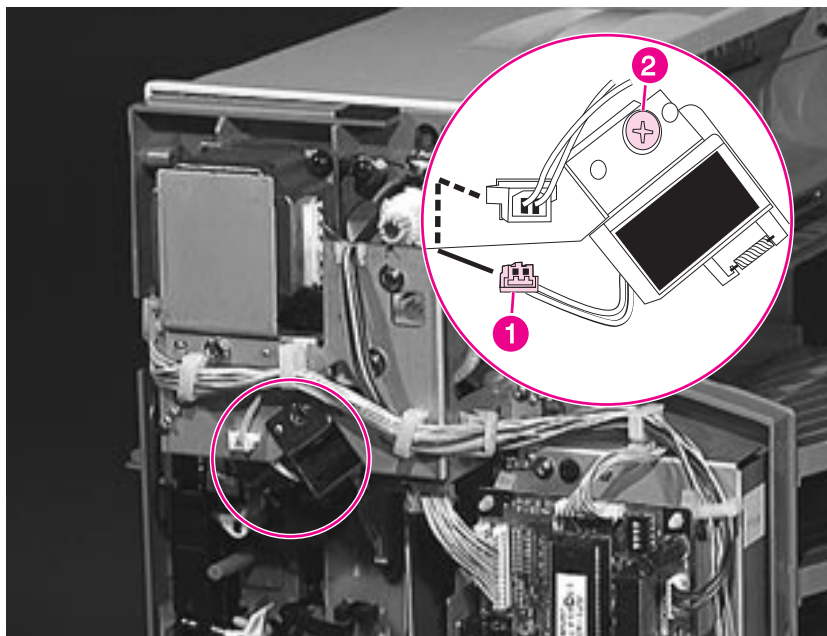

Figure 6-120 Solenoid Reversing Mechanism

- 1 Remove the Back Cover (page 263).
- 2 Unplug the cable from inside the bracket (callout 1).
- 3 Remove 1 screw and the solenoid (callout 2).

7-bin Tabletop Mailbox Solenoid Flipper

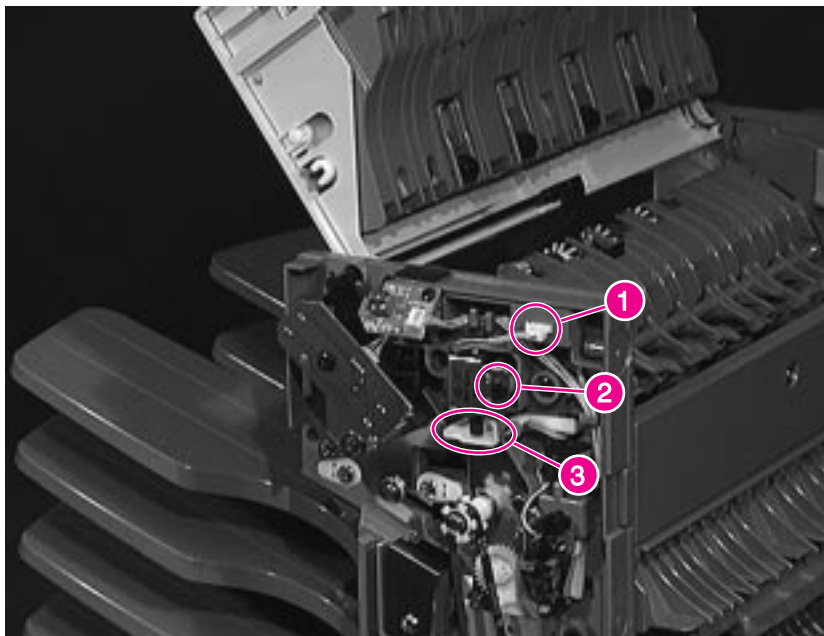

Figure 6-121 Solenoid Flipper

- 1 Remove the Front Cover (page 260).
- 2 Unplug the cable (callout 1).
- 3 Remove 1 screw and the solenoid (callout 2).
- 4 Release the solenoid.

Note

When you plug the connector in, note the orientation of the plastic part in figure 6-121 (callout 3).

7-bin Tabletop Mailbox Handle



Figure 6-122 Handle

- 1 Release the left end of the spring (callout 1).
- 2 Release the 2 tabs (callout 2), and pry the handle out.

7-bin Tabletop Mailbox Latching Mechanism

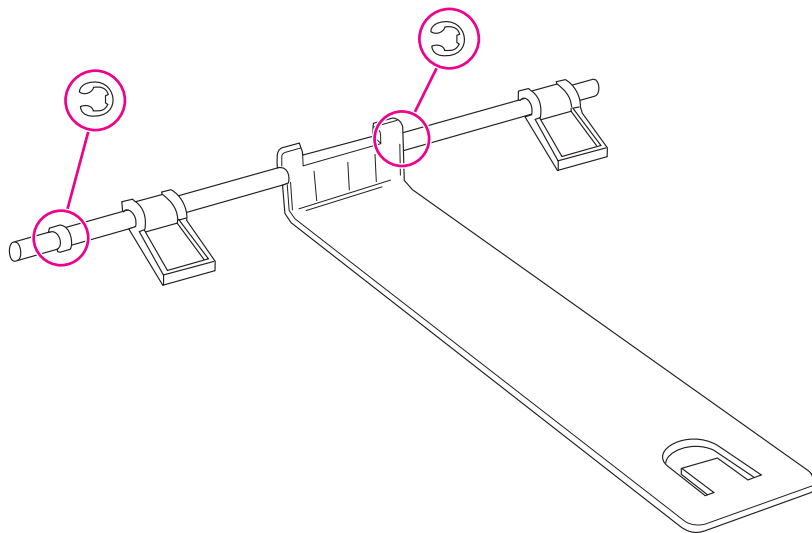

Figure 6-123 Latching Mechanism

- 1 Remove the handle (page 292).
- 2 Remove the E-clips and the bushing shown in figure 6-123. (The tab on the bushing should be on the top when you replace it.)
- 3 Slide the Latching Mechanism to the right, and remove it.

7-bin Tabletop Mailbox Cover Latch

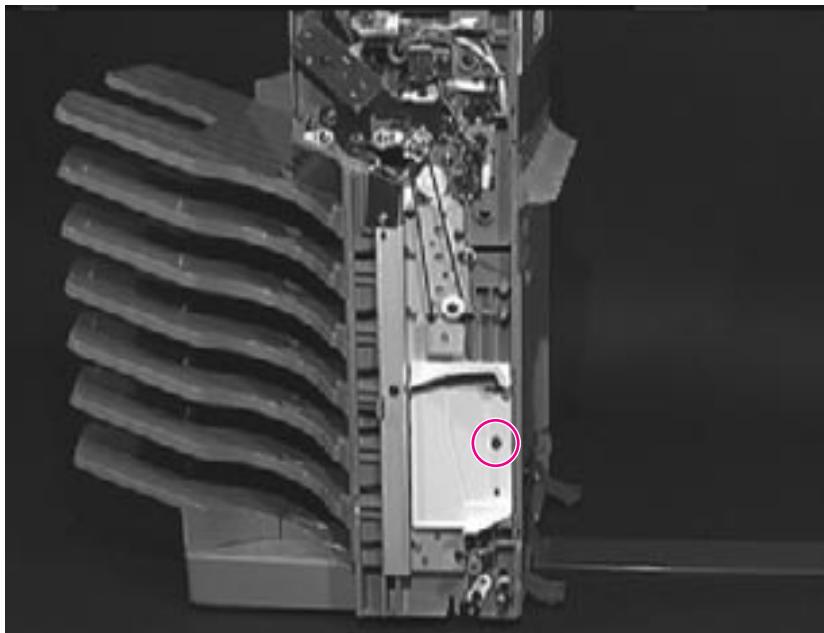

Figure 6-124 Cover Latch

- 1 Remove the handle.
- 2 Remove 1 screw, and remove the Cover Latch.

2 x 500-sheet Input Tray

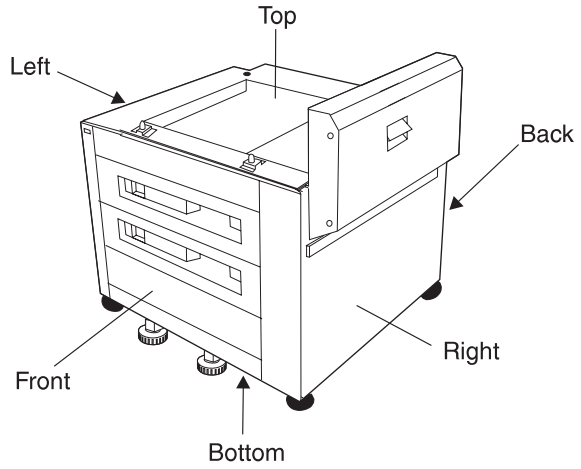

Figure 6-125 Orientation of the 2 x 500-sheet Input Tray

2 x 500-sheet Input Tray Back Cover

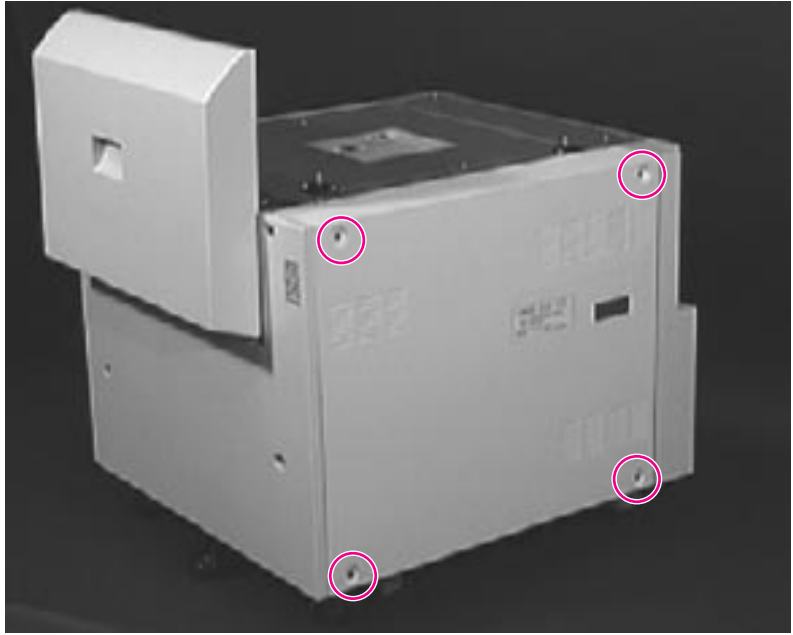

Figure 6-126 Back Cover

- 1 Remove 4 screws.
- 2 Release and pull out the Back Cover.

2 x 500-sheet Input Tray Left Cover

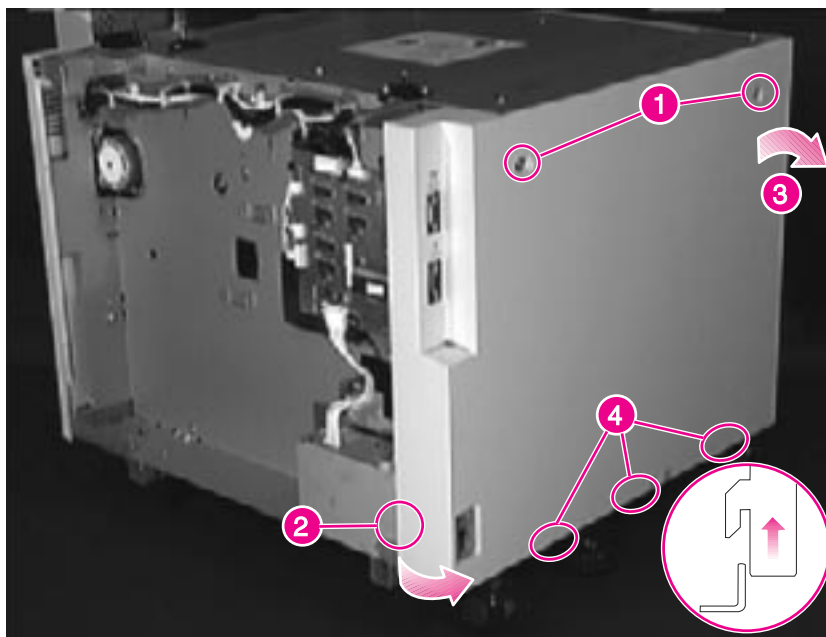

Figure 6-127 Left Cover

- 1 Unplug the power cord and C-link interface cables, and remove the Back Cover (page 296).
- 2 Remove 2 screws (callout 1).
- 3 Release the tab next to the power supply (callout 2).
- 4 Tip the cover outward to release the screw holders (callout 3).
- 5 Lift the cover up to clear the bottom tabs (callout 4).

Note

Align the screw holes with their holders when you replace the cover.

2 x 500-sheet Input Tray Vertical Transfer Unit (VTU)

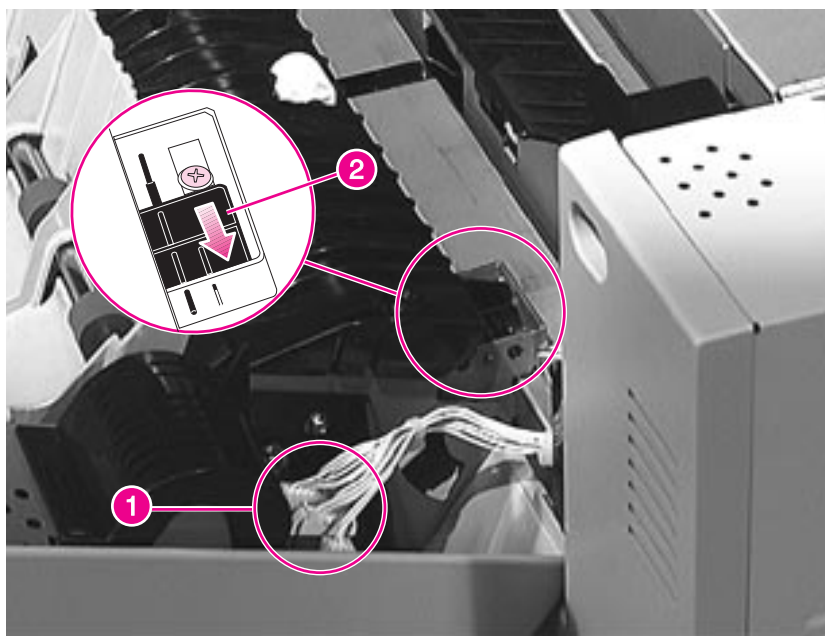

Figure 6-128 Vertical Transfer Unit (VTU) (1 of 3)

- 1 Open the Vertical Transfer Unit (VTU) on the 2 x 500-sheet Input Tray.
- 2 Unplug the 3 cables that connect the VTU to the chassis (callout 1).

WARNING!

Do **not** release the plastic cams from the secure position while the VTU is off. The springs on the cams are very strong and may cause injury.

- 3 Slide the 2 plastic cams on the VTU hinges to the secure position (callout 2).

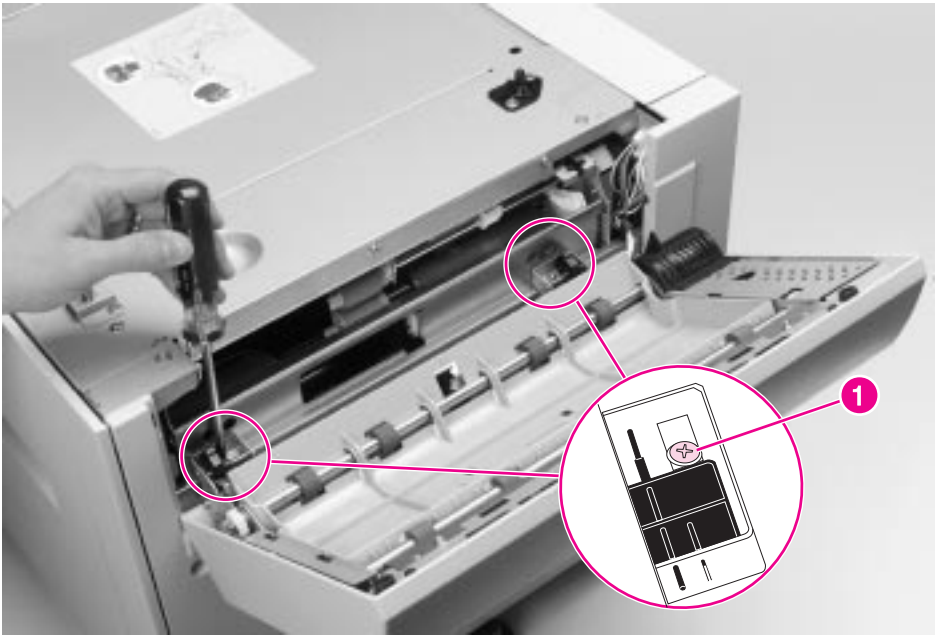

Figure 6-129 Vertical Transfer Unit (VTU) (2 of 3)

- 4 Remove the 2 screws that secure the VTU to the chassis: 1 screw near each end of the VTU (callout 1).
- 5 Lift the VTU straight up to clear the metal tabs on the chassis.

To reinstall:

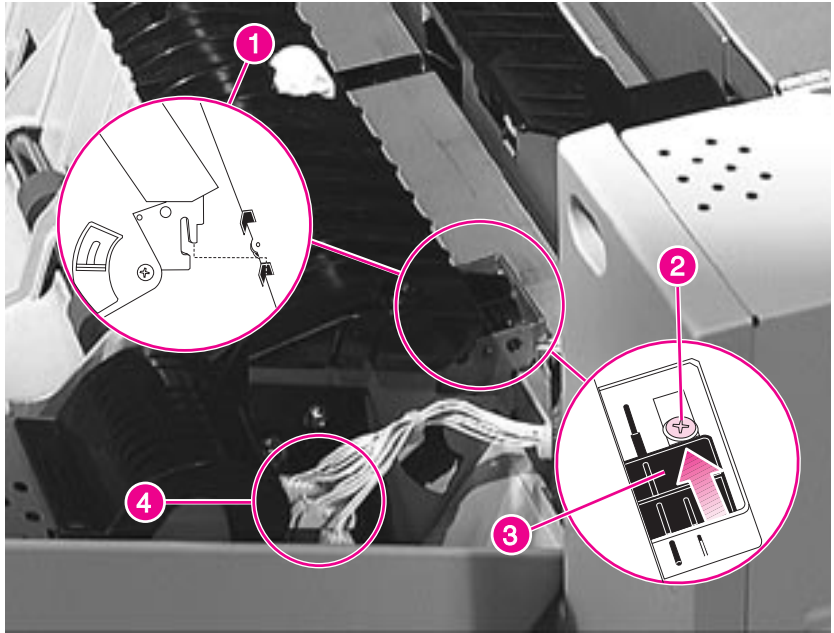

Figure 6-130 Vertical Transfer Unit (VTU) (3 of 3)

WARNING!

To avoid injury, tighten the screws that secure the VTU to the chassis **before** you release the plastic cams.

- 1 Insert the tabs into the slots (callout 1).
- 2 Tighten the screws (callout 2).
- 3 Release the cams (callout 3).
- 4 Plug in the 3 cables that connect the VTU to the chassis (callout 4).

2 x 500-sheet Input Tray Right Cover

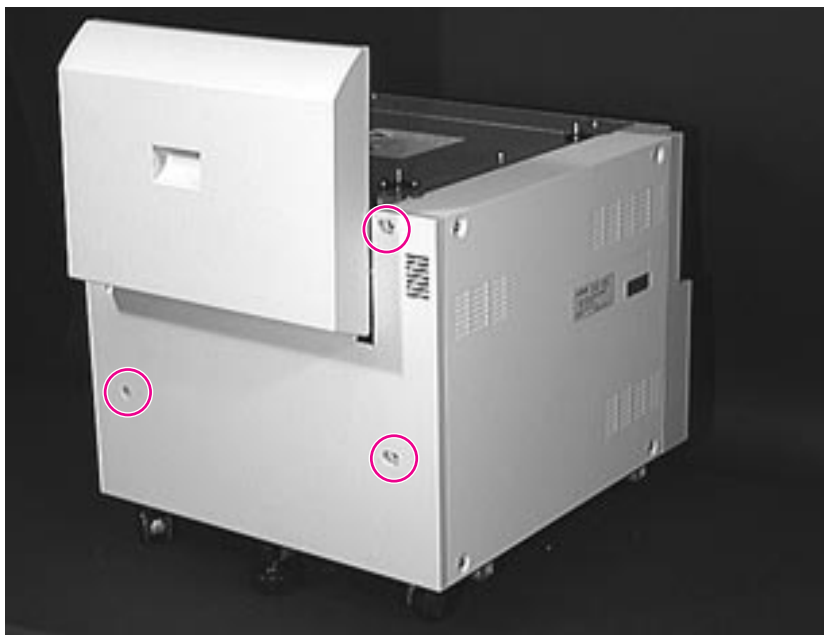

Figure 6-131 Right Cover (1 of 3)

- 1 Remove the Back Cover (page 296) and the Vertical Transfer Unit (VTU) (page 298).
- 2 Remove 3 screws.

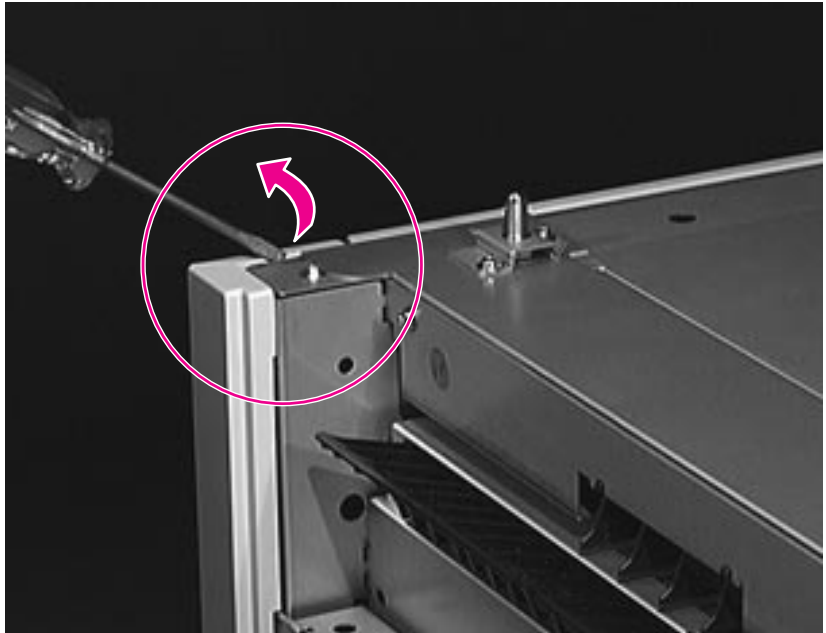

Figure 6-132 Right Cover (2 of 3)

- 3 Release the left side of the Right Cover from the tabs, and remove it.

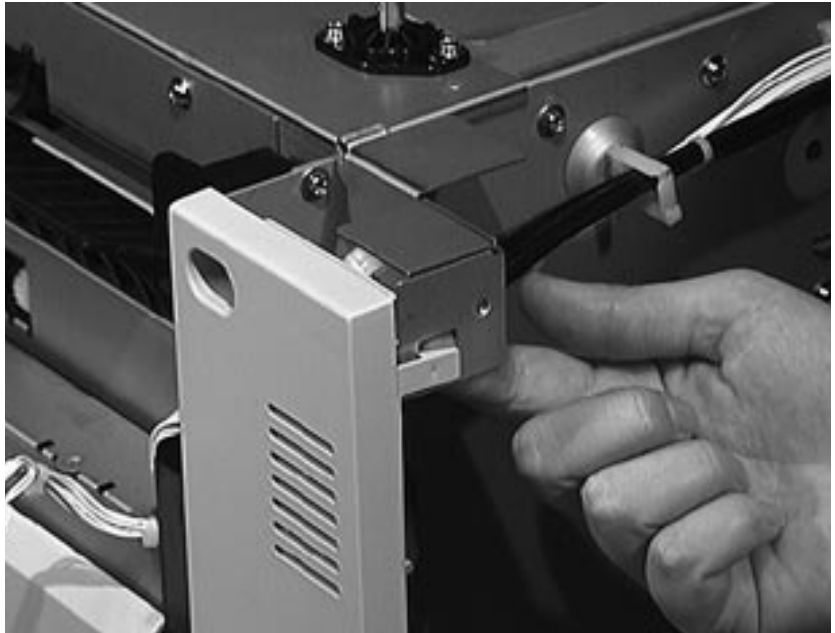

Figure 6-133 Right Cover (3 of 3)

- 4 Release the tab from the right side of the Right Cover as shown in figure 6-133.
- 5 Lift the Right Cover up to clear the tabs at the bottom.

2 x 500-sheet Input Tray Front Top Cover

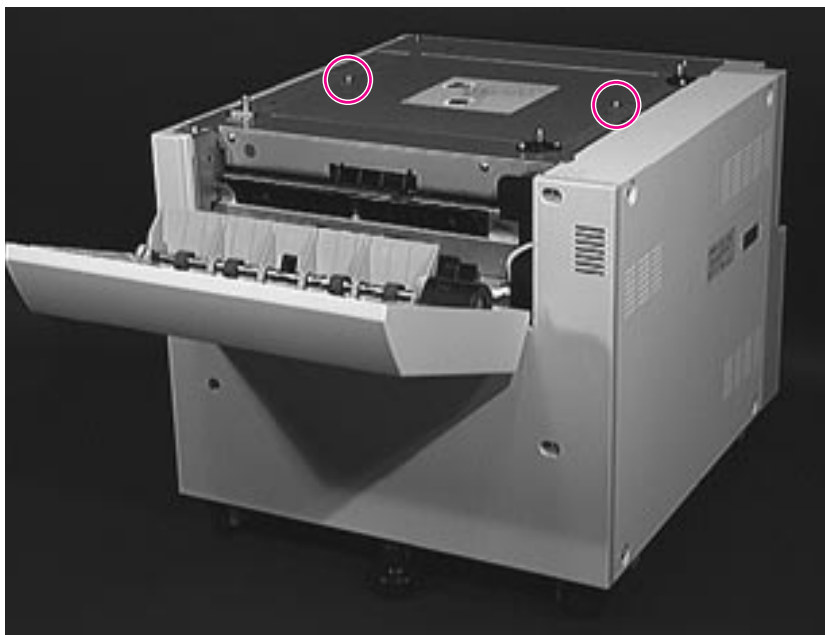

Figure 6-134 Front Top Cover (1 of 3)

- 1 Remove the engine from the 2 x 500-sheet Input Tray.
- 2 Remove 2 screws and the Top Cover (the one with a label).

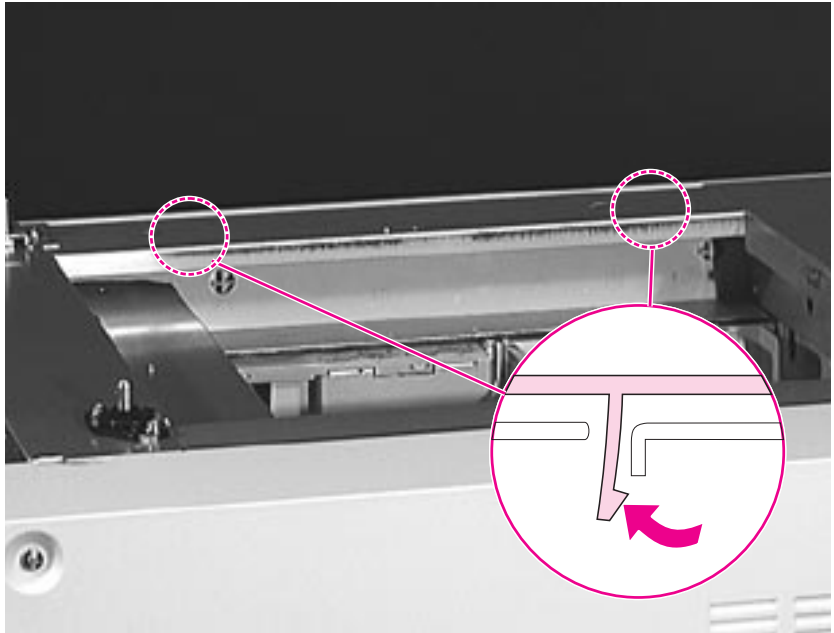

Figure 6-135 Front Top Cover (2 of 3)

- 3 From inside of the unit release the central tabs.

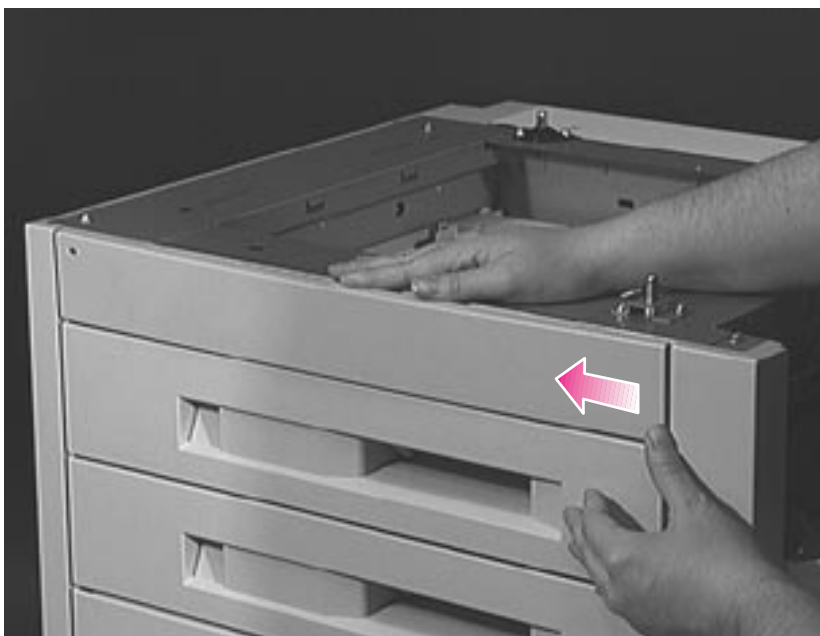

Figure 6-136 Front Top Cover (3 of 3)

- 4 Push the front top cover to the left to release the remaining tabs.

Note

Align the pins when you replace the Top Front Cover.

2 x 500-sheet Input Tray (Trays 4 and 5)

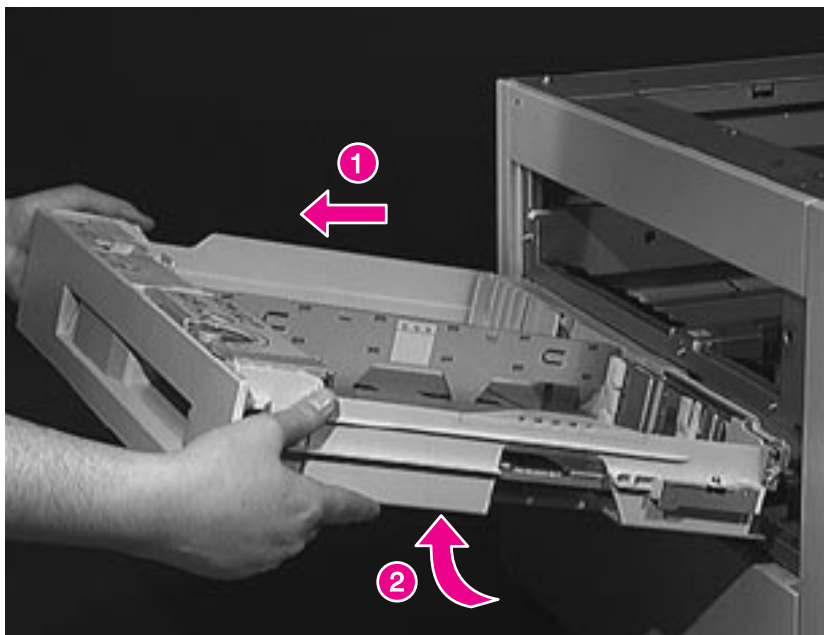

Figure 6-137 Trays 4 & 5 (1 of 2)

- 1 Open the tray and pull it out to the stop (callout 1).
- 2 As you pull out the tray, tip up the end as shown in callout 2 to release the stop mechanism at the right rear of the tray.

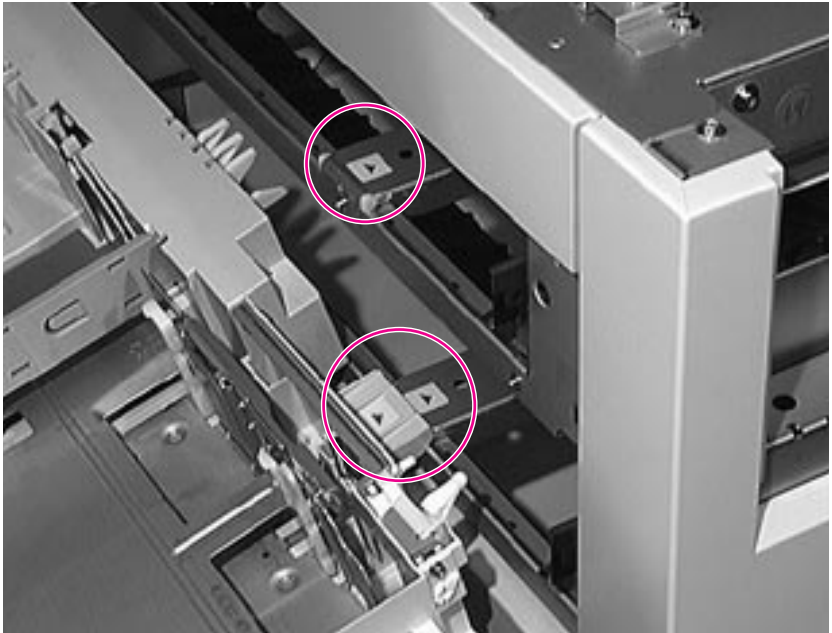

Figure 6-138 Trays 4 & 5 (2 of 2)

To Reinstall:

- 1 Tip the end of the tray downward. Align the guides with the left rear corner of the tray and the arrow at the lower rear center of the tray.
- 2 Insert the tray no more than 2 inches (5 centimeters) into the chassis.
- 3 Tip the end of the tray up to engage the tray stop mechanism (located at the right rear of the tray opening).
- 4 Slide the tray until it latches into place.

2 x 500-sheet Input Tray Pickup Assembly

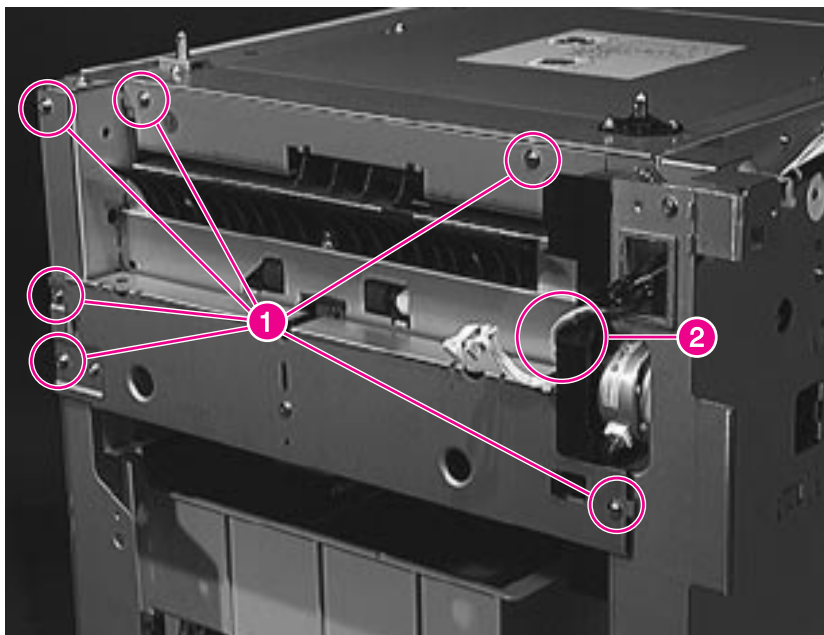

Figure 6-139 Pickup Assembly (1 of 2)

- 1 Remove trays 4 and 5 (page 307), the Right Cover (page 301), and the Vertical Transfer Unit (VTU) page 298.
- 2 Remove 6 screws (callout 1).
- 3 Remove the cable from the bracket (callout 2).

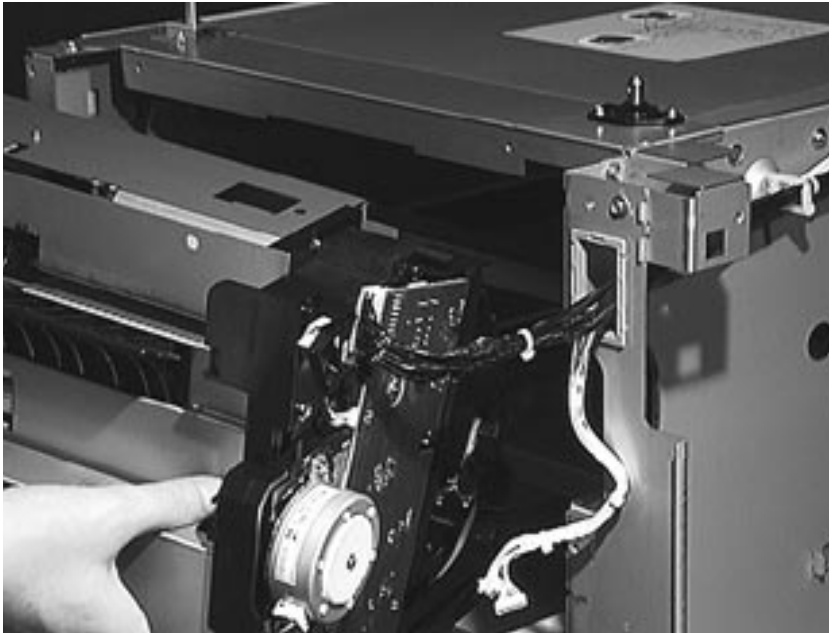

Figure 6-140 Pickup Assembly (2 of 2)

- 4 Carefully slide the Pickup Assembly straight out, supporting it until you can reach the connector.
- 5 Unplug the connector.

2 x 500-sheet Input Tray Paper Deck Drive Assembly

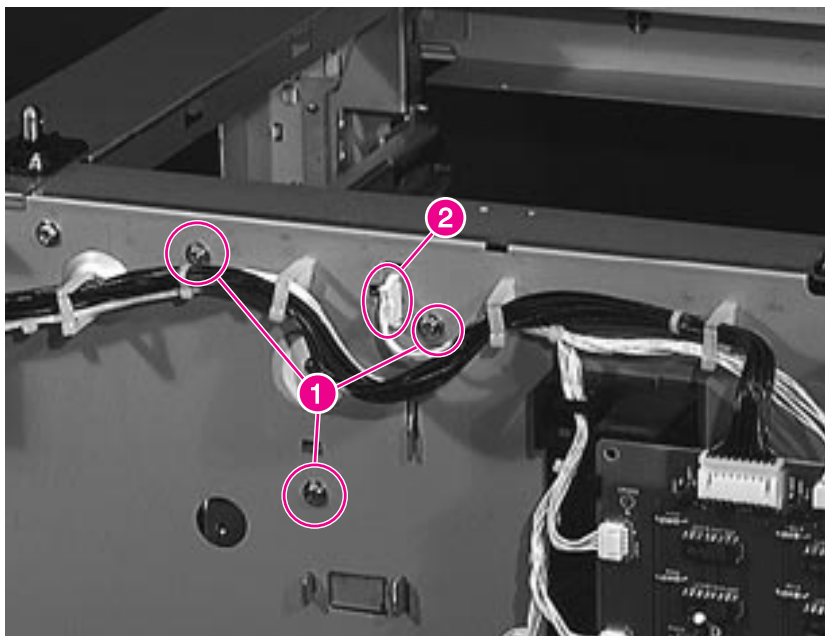

Figure 6-141 Paper Deck Drive Assembly (1 of 2)

- 1 Remove the Back Cover (page 296), Trays 4 and 5 (page 307), and the Pickup Assembly (page 309).
- 2 Remove 3 screws (callout 1).
- 3 Unplug the connector (callout 2).

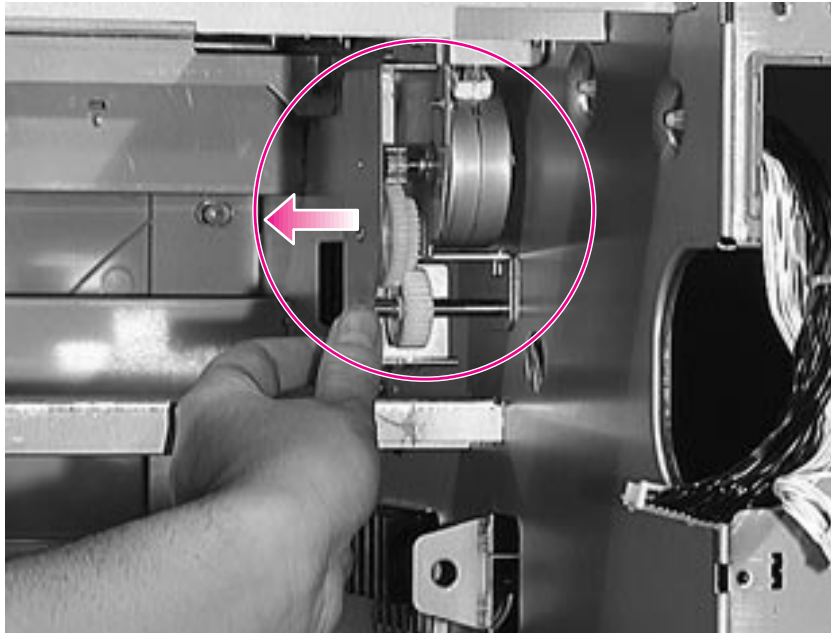

Figure 6-142 Paper Deck Drive Assembly (2 of 2)

- 4 Reach into the right side of the printer. Pull the paper deck drive assembly to the left, and then pull it straight out.

2 x 500-sheet Input Tray Pickup, Feed, and Separation Rollers

There are three rollers in this assembly. The upper forward roller is the Pickup Roller, the upper rear roller is the Feed Roller, and the lower roller is the Separation Roller. The Feed and Separation Rollers are interchangeable with each other and between the trays. The Pickup Roller is interchangeable with the Pickup Rollers in Trays 2 and 3.

- Pickup Roller: figure 6-143, callout 1
- Feed Roller: figure 6-143, callout 2
- Separation Roller: figure 6-143, callout 3

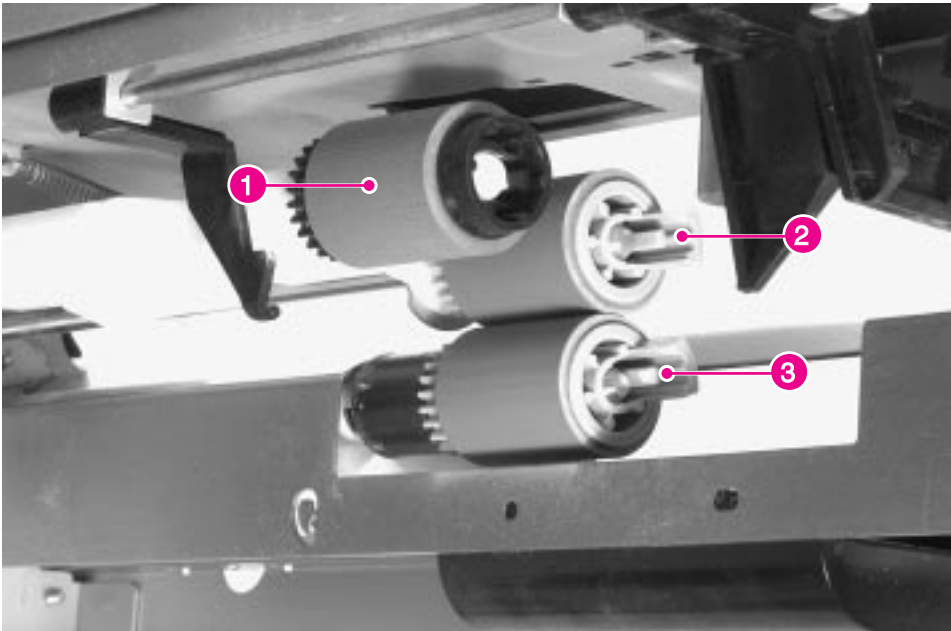

Figure 6-143 Pickup, Feed, and Separation Rollers

- 1 Remove the paper tray.

Note

The Feed and Separation Rollers have protruding retaining tabs, and the Pickup Roller has recessed retaining tabs.

- 2 From inside the tray cavity, remove the rollers by pinching the retainer tabs together and sliding the roller off the shaft.

2 x 500-sheet Input Tray Controller PCA

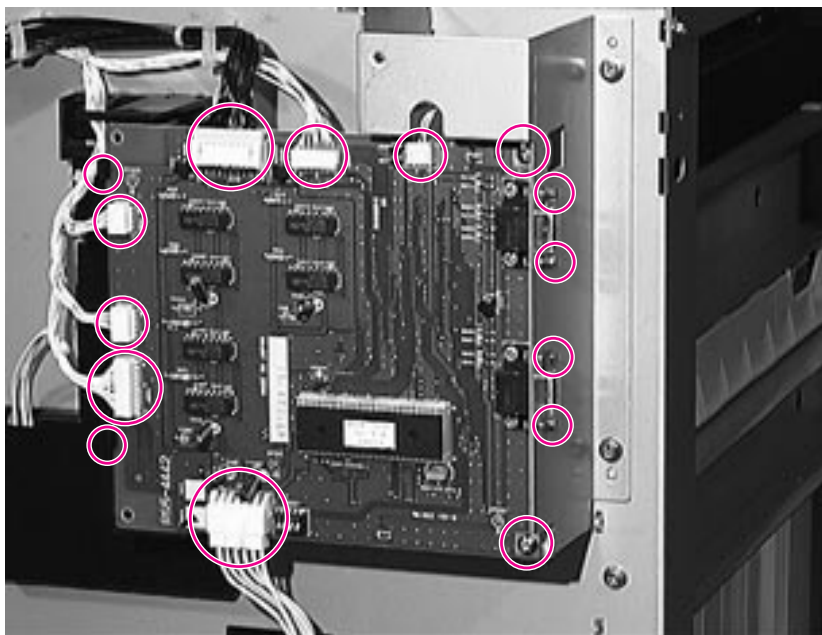

Figure 6-144 2 x 500-sheet Input Tray Controller PCA

- 1 Remove the Back Cover (page 296) and the Left Cover (page 297).
- 2 Unplug 7 connectors.
- 3 Remove 4 hex screws from the C-link connectors.
- 4 Remove the 2 screws that hold the PCA to the metal base.
- 5 Release the tabs at the left side, and remove the PCA.

2 x 500-sheet Input Tray Cassette-Size Sensing PCA

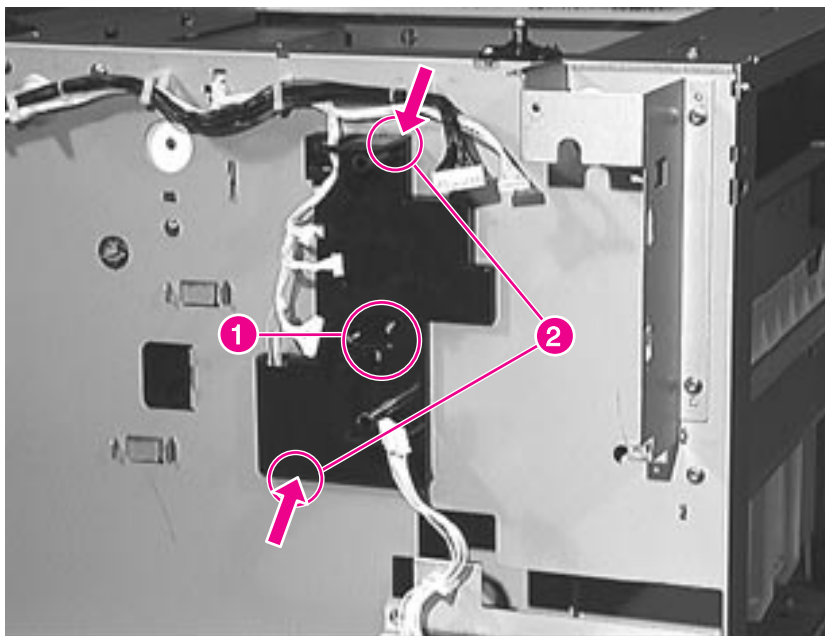

Figure 6-145 Cassette-Size Sensing PCA (1 of 2)

- 1 Remove the Back Cover (page 296) and the 2 x 500-sheet Input Tray Controller PCA (page 314).
- 2 Remove 1 screw (callout 1) from the size-sensing PCA's holder.
- 3 To remove the size-sensing PCA's holder, use a flat blade screwdriver to release the top and bottom tabs (callout 2) from the slots in the metal.

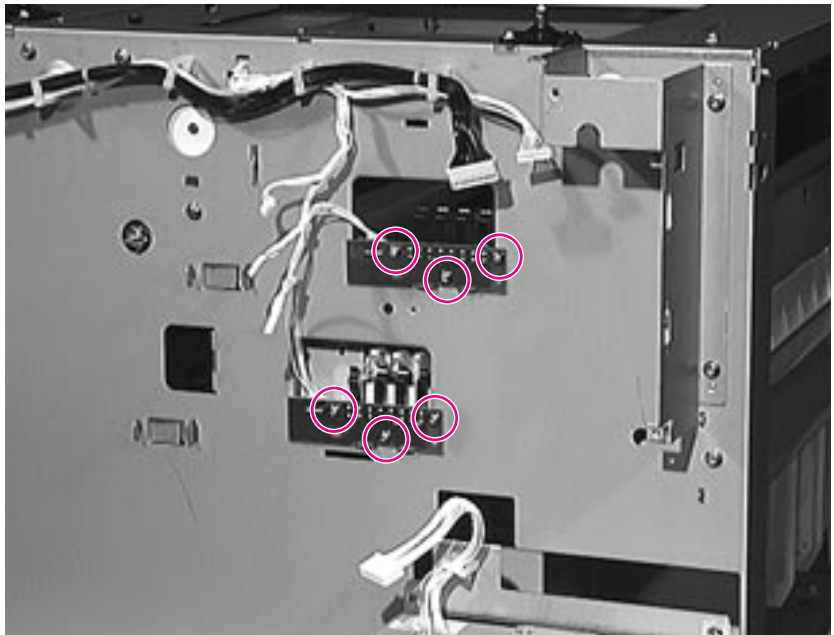

Figure 6-146 Cassette-Size Sensing PCA (2 of 2)

- 4 To remove the size-sensing PCA, unplug the cable from the PCA, remove 3 screws, and pull out the PCA.

2 x 500-sheet Input Tray Power Supply

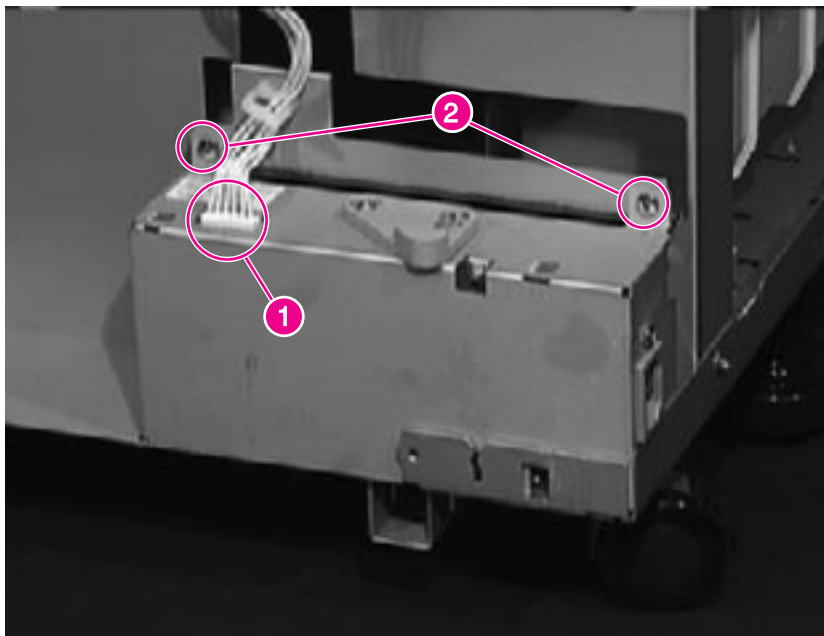

Figure 6-147 Power Supply

- 1 Remove the Back Cover (page 296) and the Left Cover (page 297).
- 2 Unplug the connector (callout 1) from the power supply. (Notice that the release tab is at the rear of the connector.)
- 3 Remove 2 screws (callout 2).
- 4 Lift the power supply off the locating pins, and slide it to the left to free it from the chassis.

To Reinstall:

- 1 Align the power supply with the locating tabs.
- 2 Plug in the power supply connector.

2 x 500-sheet Input Tray Main Cable

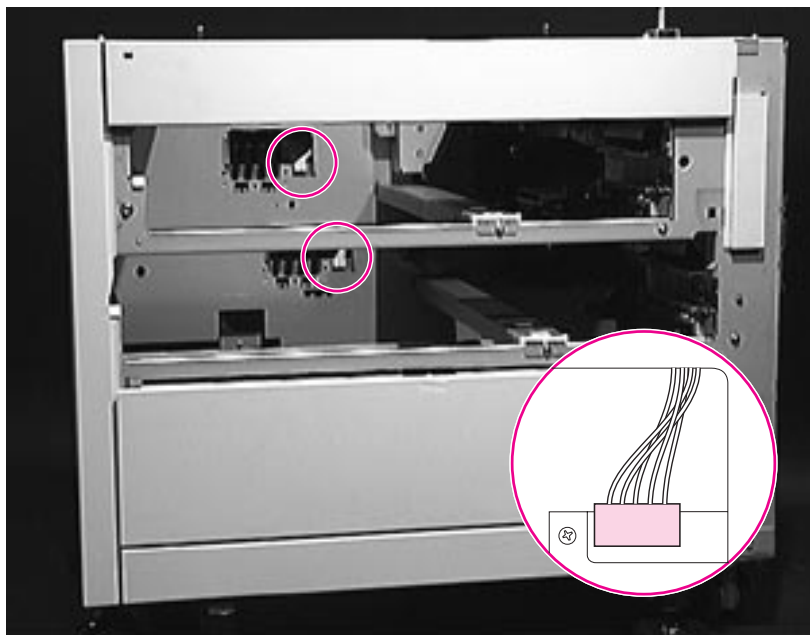

Figure 6-148 Main Cable (1 of 2)

- 1 Remove the Back Cover (page 296), the Left Cover (page 297), and Trays 4 and 5 (page 307).
- 2 Unplug both size-sensing connectors inside the 2 x 500-sheet Input Tray cavity.

Or

Remove the size-sensing PCA's holder, and unplug the cables.

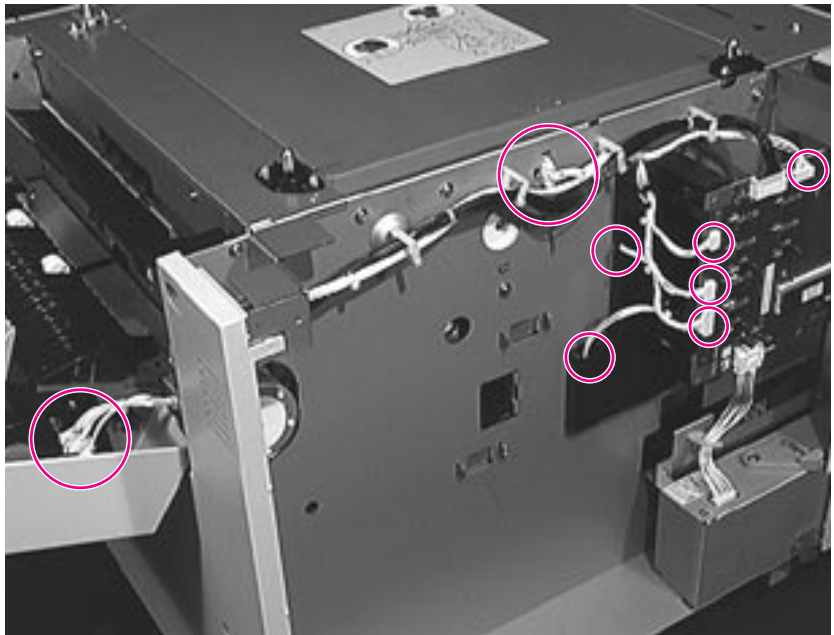

Figure 6-149 Main Cable (2 of 2)

- 3 Unplug 4 connectors from the controller PCA, 3 from the Vertical Transfer Unit (VTU), 1 from the Paper Deck Assembly, and 2 from the size-sensing PCAs.
- 4 Remove the main cable from the plastic clips.

2 x 500-sheet Input Tray Storage Paper Tray

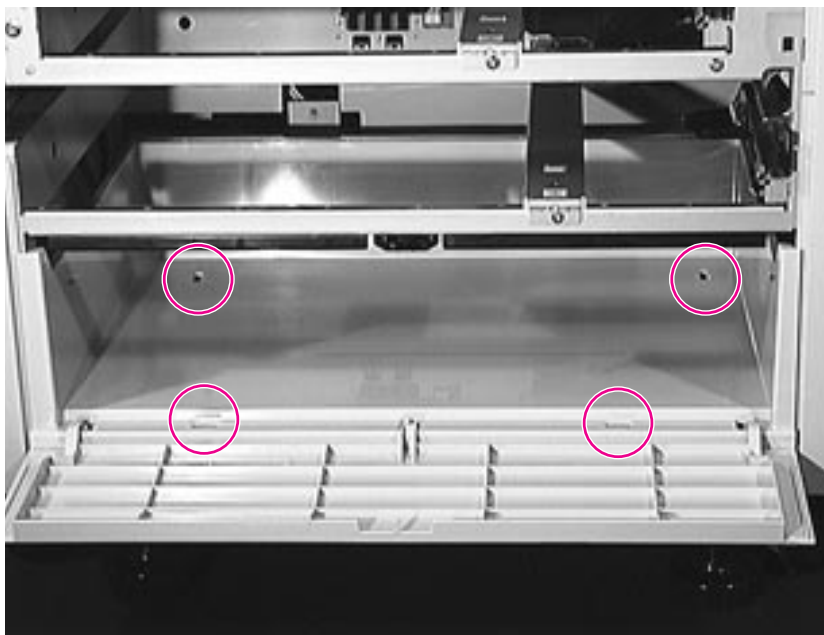

Figure 6-150 Storage Paper Tray

- 1 Remove Trays 4 and 5 (page 307).
- 2 Open the storage tray's door.
- 3 Use a flat-blade screwdriver to release the tabs inside the holes indicated in figure 6-150.

Note

Be sure to align the door's latch when you replace the Storage Paper Tray.

2 x 500-sheet Input Tray Front Door (Storage Area)



Figure 6-151 Front Door (Storage Area)

- 1 Remove the storage tray (page 320).
- 2 Release the tabs on both ends.
- 3 Release the storage tray's door from the center tab.

2 x 500-sheet Input Tray Outriggers (Leveling Feet)

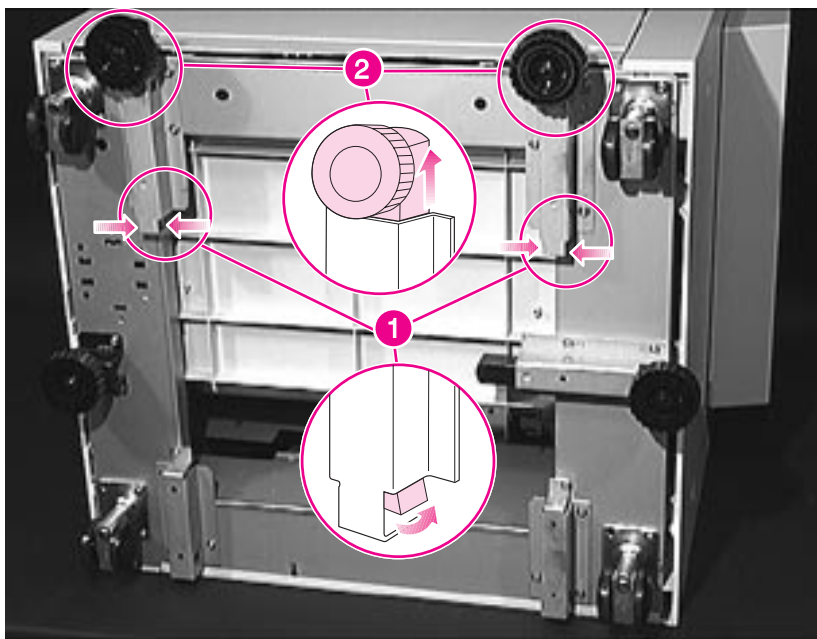

Figure 6-152 Outriggers (Leveling Feet)

- 1 Remove the engine.
- 2 Place the 2 x 500-sheet Input Tray on its left side and locate the outriggers. Remove the cap from the outrigger.
- 3 Grasp the end of the shaft, and push it toward the printer (callout 1).
- 4 Pull out the foot assembly (callout 2).

Note

Do not forget to reinstall the cap.

2 x 500-sheet Input Tray Casters

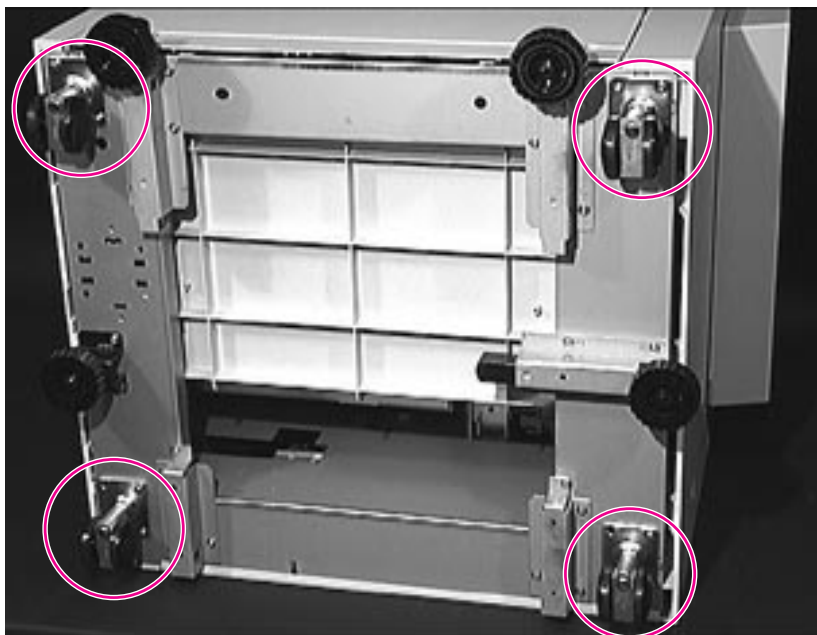

Figure 6-153 Casters

- 1 Remove the engine.
- 2 Place the 2 x 500-sheet Input Tray on its left side and locate the casters.
- 3 Remove 2 screws that hold the caster to the frame.

Note

Be sure to tighten the screws securely when you re-install the new caster.

2 x 500-sheet Input Tray Foot Tip and Adjustable Foot Tip

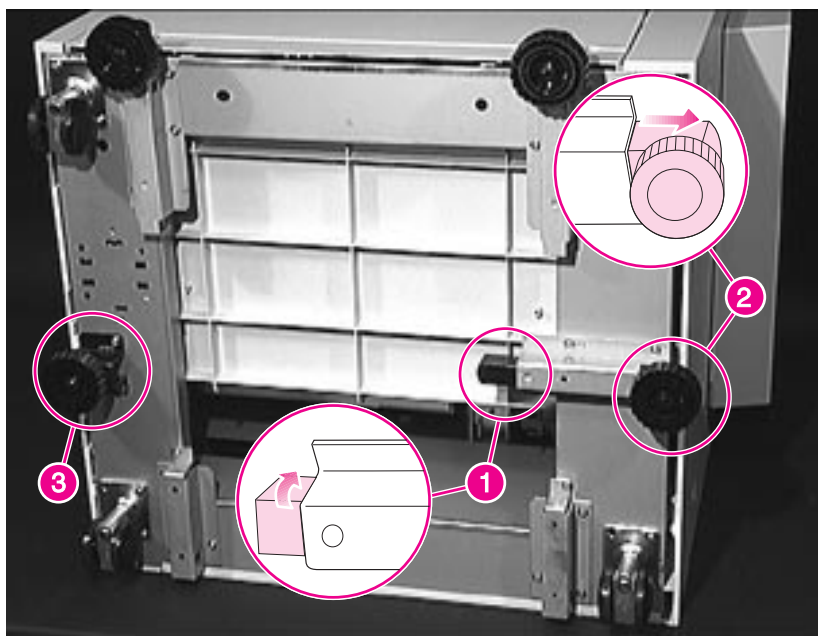

Figure 6-154 Foot Tip and Adjustable Foot Tip

- 1 Remove the engine.
- 2 Place the 2 x 500-sheet Input Tray on its left side and locate the Adjustable Foot Tip.
- 3 Push the end of the shaft on the Adjustable Foot Tip until the pin releases (callout 1).
- 4 Slide the Adjustable Foot Tip out of the bracket (callout 2).
- 5 Remove 2 screws that hold the stationary Foot Tip to the frame.

Note

Be sure to orientate the new adjustable foot tip properly.

2 x 500-sheet Input Tray Locating Pins



Figure 6-155 Locating Pins

- 1 Remove the engine.
- 2 Remove 2 screws each from the 3 locating pins.

2 x 500-sheet Input Tray Front LED PCA

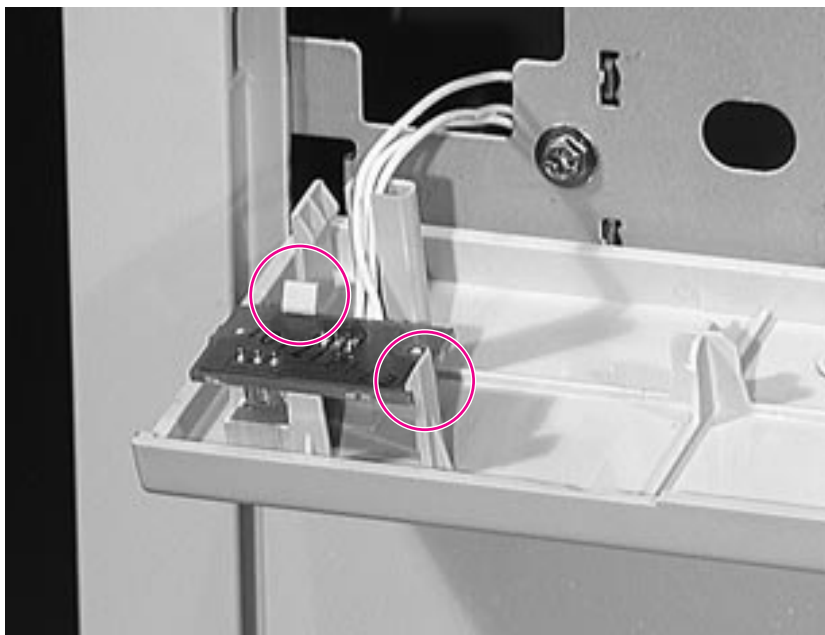

Figure 6-156 Front LED PCA

- 1 Remove the Front Top Cover (page 304).
- 2 Unplug the cable.
- 3 Release the tabs and remove the LED PCA.

Note

Guide the cable into the correct position when you replace it.

7 Troubleshooting

Chapter contents

Troubleshooting Process - - - - -	328
Power On - - - - -	332
Display - - - - -	336
Information Pages - - - - -	340
Communication - - - - -	346
Printer Messages - - - - -	351
Image Quality - - - - -	394
Troubleshooting Checks - - - - -	412
Diagnostics on Accessories - - - - -	418
General Troubleshooting Information - - - - -	426

Troubleshooting Process

The troubleshooting process is a systematic approach that addresses the major problems first and then other problems as you identify the causes for printer malfunctions and errors. The Troubleshooting Process, figure 7-1 on page 330 and figure 7-2 on page 331, illustrates the major steps for troubleshooting the printing system. Each heading depicts a major troubleshooting step. A **YES** answer to the questions allows you to proceed to the next major step.

A **NO** answer indicates that additional testing is needed. Proceed to the referenced location and follow the directions for that area. After completing the additional testing, proceed to the next major step.

The following list describes the basic questions for the customer and the corresponding troubleshooting step to help you quickly define the problem(s).

Table 7-1. Major Steps for Troubleshooting

"Display" on page 336	Does the display panel indicate READY, OFFLINE, or POWERSAVE ON? Contains the procedures for correcting control panel messages and displaying and correcting Event Log codes.
"Information Pages" on page 340	Will the printer print a configuration page successfully? Contains the procedures for printing the configuration page and evaluating and correcting system configuration.
"Image Quality" on page 394	Does the print quality meet customer expectations? Contains the image quality comparison tables, cleaning procedures, toner cartridge checks, and High-voltage Power Supply checks.
"Event Log" on page 336	Are there recurring problems in the Event Log? Contains information about printing the Event Log and evaluating the error history.
"Communication" on page 346	Can the customer print from the host system successfully? Describes how to determine if the printer is communicating properly with the host system.
"Troubleshooting Checks" on page 412	Will the printer print from all sources to all destinations, and have all of the errors in the Event Log been addressed? Contains procedures for verifying the overall printer system operation.

Table 7-1. Major Steps for Troubleshooting (continued)

"Printer Messages" on page 351	Does the control pane display an error message? Contains a list of control panel error messages and recommended actions.
--	--

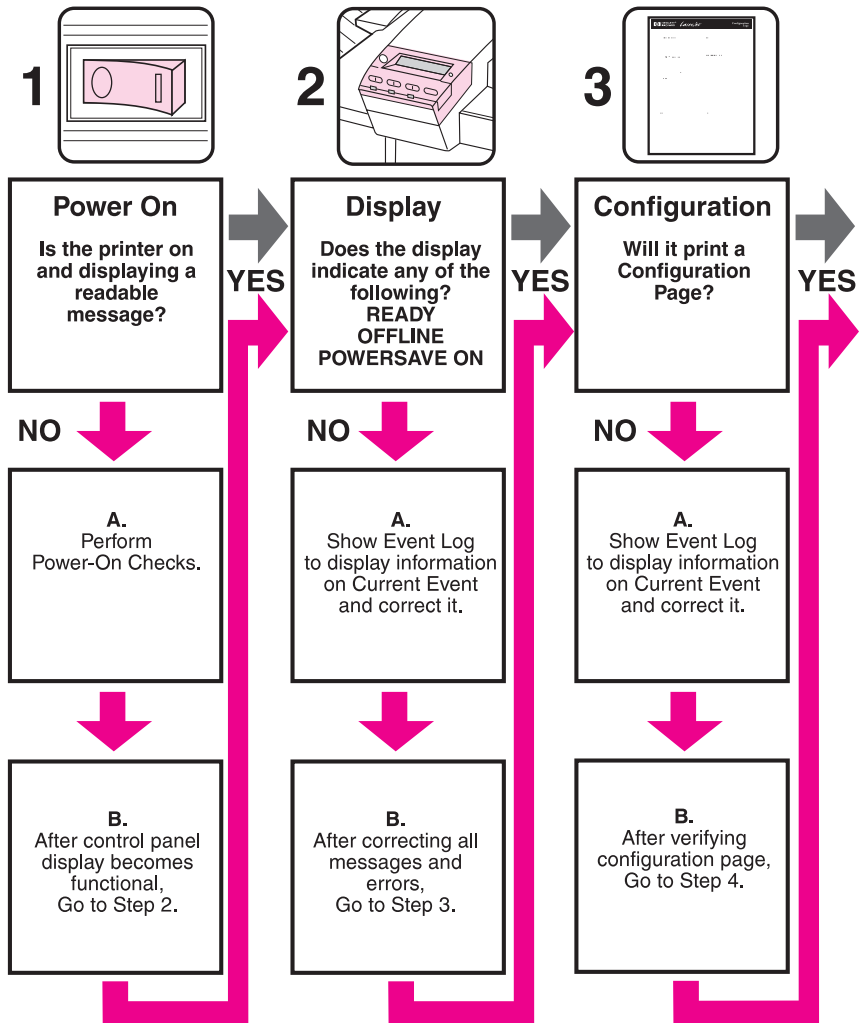

Figure 7-1 HP LaserJet Troubleshooting Process (1 of 2)

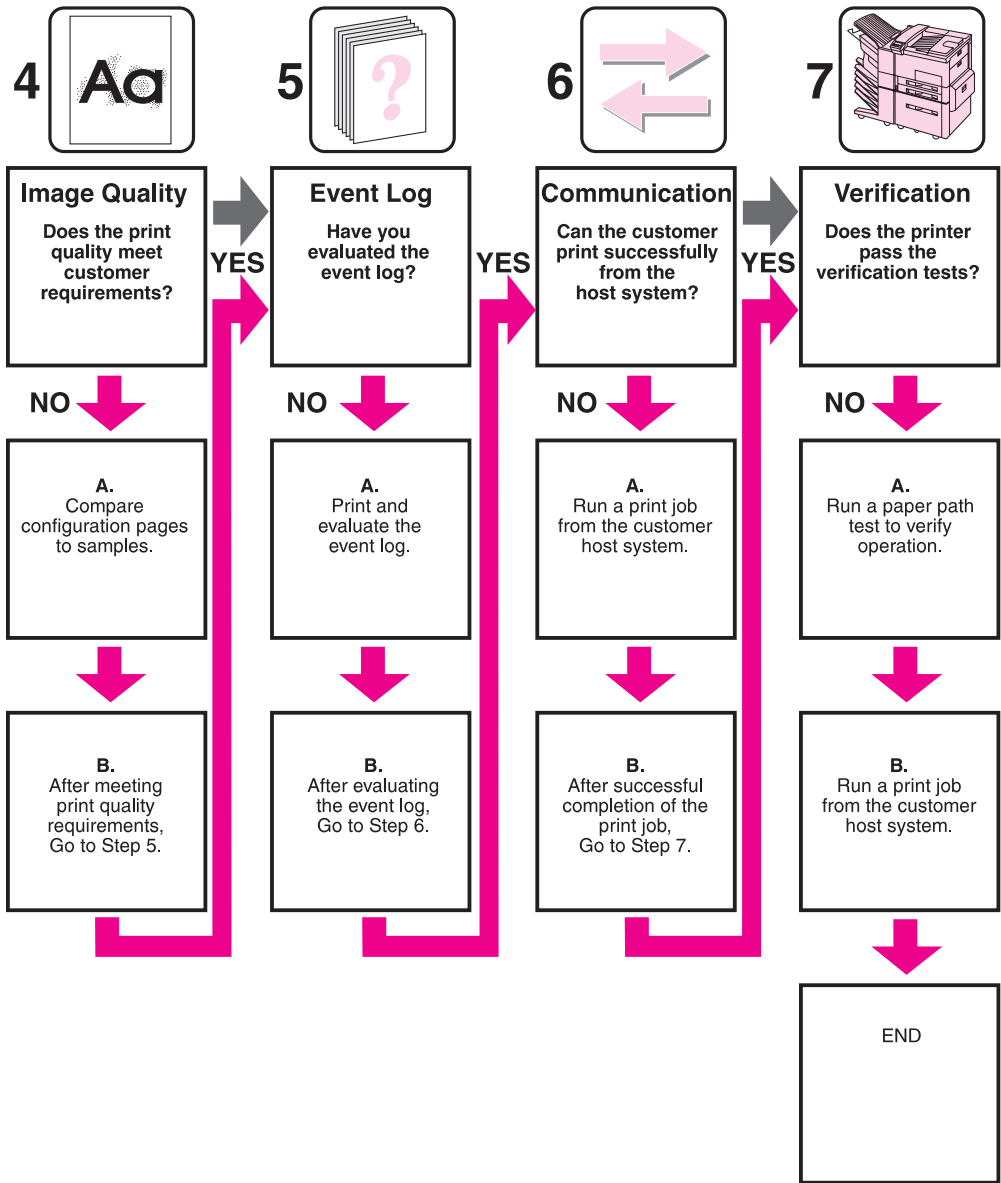

Figure 7-2 HP LaserJet Troubleshooting Process (2 of 2)

Power On

Overview

It is important to have the printer's Control Panel functional as soon as possible in the troubleshooting process so that the printer's diagnostics can assist in locating printer errors.

Table 7-2. Power On

Problem	Action
1. Is AC power available at the printer's power receptacle?	Verify. See table 1-5, "Electrical Specifications," on page 9.
2. Is the printer's on/off switch set to on?	Push the switch to the on position.
3. Are the printer's fans on? (See figure 7-3 on page 334 to locate the fans.)	<p>Note: Fan operation is significant since all fans are controlled by the printer's DC Controller PCA. When the printer is in PowerSave mode, the fans are off. Make sure that the printer is not in PowerSave mode. Press Go. Operational fans indicate:</p> <ol style="list-style-type: none">1. AC power is present in the printer.2. DC power supply is functional (both 24V DC and 5V DC are being generated).3. DC Controller PCA's micro-processor is functional. <p>NO If the fans are NOT working, turn off the printer and remove the printer's Formatter PCA. Disconnect all the printer's paper handling options. Then turn on the printer and check the fans again.</p> <p>If the fans are still not working, perform the following steps:</p> <ol style="list-style-type: none">1. Verify that all fans are connected to the DC Controller PCA according to figure 7-19 on page 438.2. Replace the low-voltage DC power supply. See "Power Supply, Low Voltage (LVPS)" on page 206 for instructions.3. Replace the DC Controller PCA. See "PCA, DC Controller" on page 197 for instructions.

Table 7-2. Power On (continued)

Problem

Action

YES If the fans are working but the printer's Control Panel is blank, print an engine test. See "Engine Test" on page 335.

If the engine test was successful, perform the following steps:

1. Reseat or replace the cable from the Control Panel that is connected to J203 of the DC Controller PCA (see the main wiring diagram in the back of the manual).
2. Replace the printer's Formatter PCA. See "Formatter Assembly" on page 185 for instructions.
3. Replace the Control Panel assembly. See "Control Panel" on page 159 for instructions.

If the engine test was not successful, verify that there is no paper in the paper path. Retry the engine test. If the engine test is still unsuccessful, replace the DC Controller PCA. See "PCA, DC Controller" on page 197 for instructions.

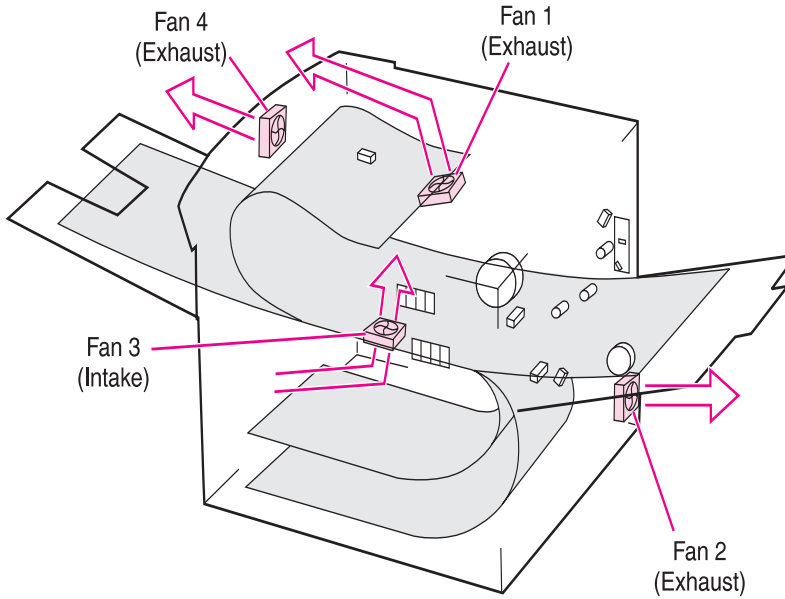

Figure 7-3 Fan Location and Airflow

Table 7-3. Fans

Fan Name	Fan Location
1. Laser/Scanner Fan	Exhaust air flows from the back of the printer, on the left-hand side of the fusing assembly.
2. Low-voltage Power Supply Fan	Lower right-hand corner of the printer.
3. Formatter Fan (intake)	Intake fan directly above the input power receptacle.
4. Standard Output Delivery Fan	Directly above the center of the fusing assembly.

Engine Test

The engine test verifies that the print engine is functioning correctly. This test is very useful for isolating printer problems since the Formatter PCA is completely bypassed during an engine test. This test is very useful for isolating printer problems. The engine test prints a full page of horizontal lines across the entire printable area and is also useful for checking and adjusting registration. The engine test prints from Tray 3 only and can be activated with the Formatter PCA removed.

Note

Tray 3 **must** be installed and loaded with paper to perform an engine test. Also, make sure that the EP toner cartridge is installed in the printer.

Engine Test Button Location

The engine test button is located on the DC Controller PCA. It is accessible through a hole at the right rear of the printer.

Printing an Engine Test

To print an engine test, use a non-metallic object (such as a pencil) to press the engine test button (see figure 7-4). A single test page will print.

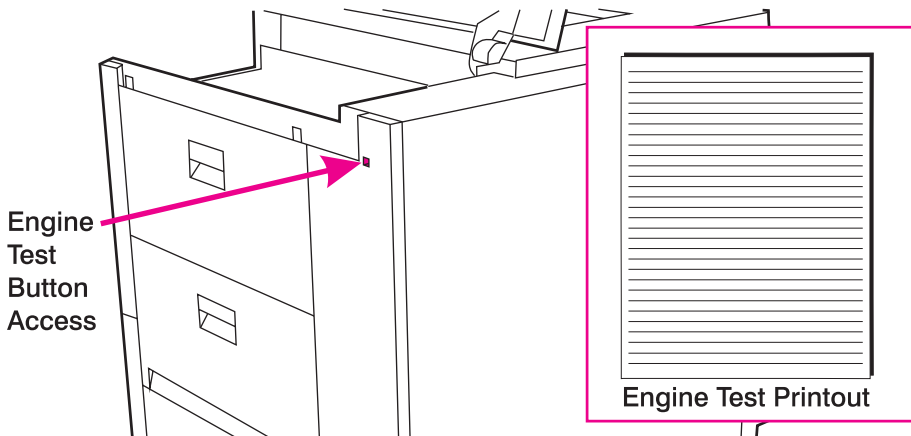

Figure 7-4 Engine Test Button

Display

Event Log

Use the Event Log to diagnose and troubleshoot printer errors and intermittent failures. You can either print or display the Event Log from the Control Panel's Information Menu. (Select `PRINT EVENT LOG` or `SHOW EVENT LOG`.) (The Configuration Page lists the maximum number of entries in the Event Log.)

See figure 7-5 on page 337 for a sample Event Log. The Event Log shows the current page count at the left side of the page, with the printer's serial number directly to the right of the page count. The left column is the error sequence number, with the error listed on the right (the highest sequence number is the most recent event logged). The next column is the page count at the time of the error, and the last column is the Personality (PCL or PostScript) column or the Jam Cause at the time of the error.

See table 7-5, "Alphabetical Printer Messages," on page 352 and table 7-6, "Numerical Printer Messages," on page 373 for more information about correcting Event Log messages in the printer.

Event Log Page

1

Current Page Count: 0 Serial Number: USMT173335

Number	Error	Page Count	Description or Personality
--------	-------	------------	----------------------------

1	13.3 13	1	PAPER FEED 2, PAPER LATE JAM
---	---------	---	------------------------------

 **Most recent error**

Figure 7-5 **Sample Event Log**

Print the Event Log

The printer's internal Event Log stores the most recent errors and can be printed at any time. To print the Event Log:

1. Press **Menu** until INFORMATION MENU appears.
2. Press **Item** until PRINT EVENT LOG appears.
- 3 Press **Select** to print the Event Log.

Display the Event Log

If the printer cannot print or move any paper, follow these steps to display the Event Log. Otherwise, print the Event Log.

1. Press **Menu** until INFORMATION MENU appears.
2. Press **Item** until SHOW EVENT LOG appears.
3. Press **Select** to show the Event Log.
4. Press **- Value +** to scroll through the Event Log.
5. Write down the error messages. For example:

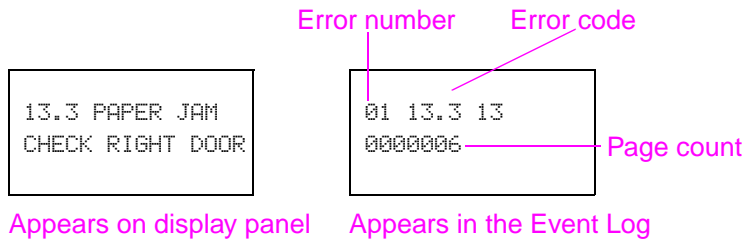

6. Check the Event Log for specific error trends in the last 10,000 printed pages.
7. Ask the customer for any observed error trends. (For example, do paper jams tend to occur in a specific area of the printer?)
8. Record any specific error trends.
9. See table 7-5, "Alphabetical Printer Messages," on page 352 and table 7-6, "Numerical Printer Messages," on page 373 and follow the recommended action.
10. If the Control Panel displays **READY**, **OFFLINE**, or **POWERSAVE ON**, go to the next section. If it displays any other message, repeat this procedure starting from step 1.

Interpret the Event Log

See figure 7-5 on page 337 for a sample Event Log.

The errors on the control panel and the Event Log codes may not be the same. For example, 13.11 on the control panel may be 13.11 1B in the Event Log. The 1B provides more information about the error. Likewise, if a 50.1 FUSER ERROR is displayed on the Control Panel, the Event Log will record a 50.02.01 error, with the 02 signifying that 2 sensors were blocked. Make sure that you refer to the correct number in table 7-5, “Alphabetical Printer Messages,” on page 352 and table 7-6, “Numerical Printer Messages,” on page 373.

When an error is detected in an Optional Paper Handling Device, a 13.11, 13.22, or 66.xx.zz will be displayed on the Control Panel.

Hint

Whenever a 13.xx appears on the Control Panel, a good practice is to clear the jammed paper from the printer, press **Go** to take the printer offline, and print the Event Log. If you cannot print the Event Log, you can still display it on the Control Panel. The last error is the error at the top of the Event Log printout with the highest number in the left-most column. Write the error next to the last error logged.

To interpret the Event Log:

- Each individual entry in the log is called an “error,” while all errors occurring at the same page count are called an “event.” See the Recommended Action in table 7-5, “Alphabetical Printer Messages,” on page 352 and table 7-6, “Numerical Printer Messages,” on page 373 for each error comprising an event to gain a clear picture of what took place during that event. Events usually conclude with a time-out or no response from the device (error 66.xx in the Event Log). Turn the printer off, and then turn the printer on.
- It is assumed that any Paper Handling Devices are connected as shown in the C-link Cable Diagram (figure 7-8 on page 346). The errors will be logged with different device numbers if any non-standard cabling is installed.
- Use the Event Log table in this section to associate errors in the Event Log with the Control Panel error message. Follow the Recommended Action listed in the Event Log Table starting on page 352 for each error or event.

Information Pages

From the printer's Control Panel you can print pages that give details about the printer and its current configuration. The following information pages are described here:

- Menu Map
- Configuration Page

For a complete list of the printer's information pages, print a Menu Map and see the Information Menu.

Menu Map

To see the current settings for the menus and items available in the Control Panel, print a Control Panel Menu Map:

- 1 Press **MENU** until `INFORMATION MENU` appears.
- 2 Press **ITEM** until `PRINT MENU MAP` appears.
- 3 Press **SELECT** to print the Menu Map.

The content of the Menu Map varies, depending on the options currently installed in the printer. The printer driver or software application can override many of these values. See figure 7-6 on page 341 for a sample Menu Map.

Menu Map

1

INFORMATION MENU

PRINT
MENU MAP
PRINT
CONFIGURATION
PRINT
PCL FONT LIST
PRINT
PS FONT LIST
PRINT
EVENT LOG
SHOW
EVENT LOG
PRINT
PAPER PATH TEST

PAPER HANDLING MENU

TRAY 1 MODE=
FIRST
TRAY 2 TYPE=
PLAIN
TRAY 3 TYPE=
PLAIN
PAPER DEST=
STANDARD OUTBIN
MANUAL FEED=OFF
OVERRIDE
A4/LETTER=NO
CONFIGURE FUSER
MODE MENU=NO

PRINT QUALITY MENU

RESOLUTION=
FASTRES 1200
RET=MEDIUM
ECONOMODE=OFF
TONER DENSITY=3
CREATE
CLEANING PAGE

PRINTING MENU

COPIES=1
PAPER=
LETTER
CONFIGURE CUSTOM
PAPER=NO
FORM=60 LINES
ORIENTATION=
PORTRAIT
PCL FONT SOURCE=
INTERNAL
PCL FONT NUMBER=
0
PCL FONT PITCH=
10.00
PCL SYMBOL SET=
PC-8
COURIER=REGULAR
WIDE A4=NO

 **Menu Continued**

APPEND CR TO LF=
NO
PRINT PS ERRORS=
OFF

CONFIGURATION MENU

POWERSAVE=
30 MINUTES
PERSONALITY=
AUTO
RESOURCE SAVE=
OFF
CLEARABLE
WARNINGS=JOB
AUTO CONTINUE=
ON
TONER LDR=
CONTINUE
RAM DISK=OFF
JAM RECOVERY=
AUTO
SMALL PAPER
SPEED=NORMAL

I/O MENU

I/O TIMEOUT=15
I/O BUFFER=AUTO
PARALLEL HIGH
SPEED=YES
PARALLEL ADV
FUNCTIONS=ON
SERIAL PACTING=
DTR/DSR
SERIAL BAUD
RATE=9600
SERIAL DTR
POLARITY=HIGH

EIO 3 JETDIRECT MENU

CFG NETWORK=NO

RESETS MENU

RESET MEMORY
RESTORE FACTORY
SETTINGS
RESET ACTIVE I/O
CHANNEL
RESET ALL I/O
CHANNELS

Figure 7-6

Sample Menu Map

Configuration Page

Use the configuration page to view current printer settings, help troubleshoot printer problems, or verify installation of optional accessories, such as memory (DIMMs), paper trays, and printer languages.

To print a configuration page:

- 1 Press **MENU** until INFORMATION MENU appears.
- 2 Press **ITEM** until PRINT CONFIGURATION appears.
- 3 Press **SELECT** to print the configuration page.

See figure 7-7 on page 343 for a sample configuration page. The content of the configuration page varies, depending on the options currently installed in the printer.

If any of the installed devices are not shown on the configuration page, verify that the C-link cabling is correctly connected and functional (figure 7-8 on page 346) and that DC power is available to the paper handling devices. Check and reseal suspect cable connections. If any of the cables are replaced, you must cycle the power to have the printer recognize the device again.

The Menu Map shows current control panel settings. See figure 7-6 on page 341 for a sample Menu Map. See chapter 3 for information about the default settings.

Printer Information

Lists the serial number, HP JetSend IP addresses, page counts, and other information for the printer.

Memory

Lists printer memory, PCL Driver Work Space (DWS), and I/O buffering and resource saving information.

Event Log

Lists the number of entries in the log, the maximum number of entries viewable, and the last three entries.

Security

Lists the status of the printer's Control Panel lock, Control Panel password, and disk drive.

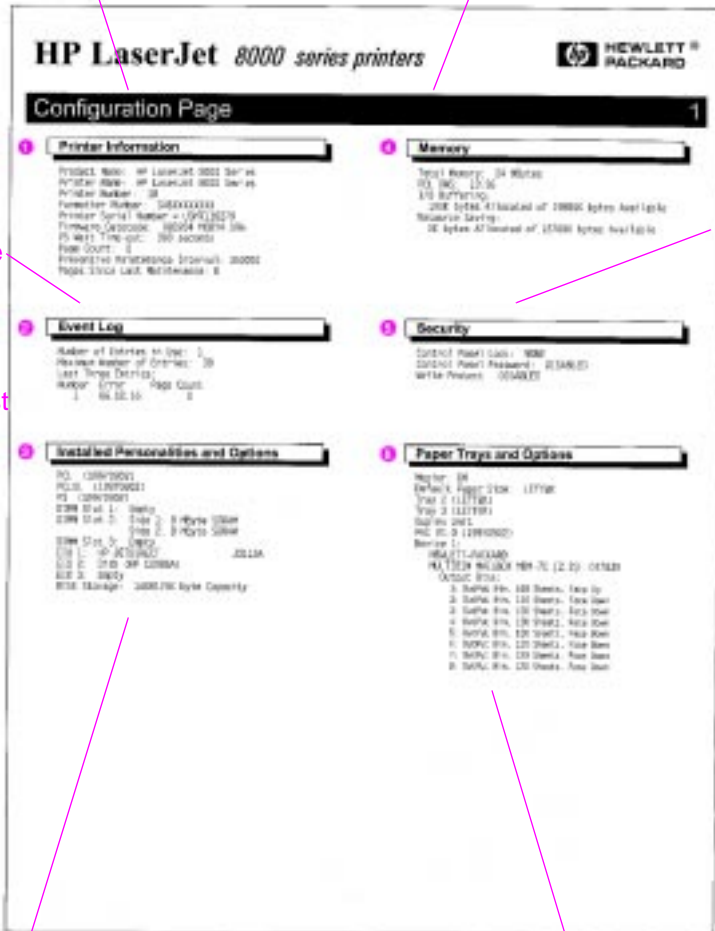

Installed Personalities and Options

Lists all printer languages that are installed (such as PCL and PS) and lists the options that are installed in each DIMM slot and EIO slot.

Paper Trays and Options

Lists the size settings for all the trays and lists the optional paper handling accessories that are installed.

Figure 7-7 Sample Configuration Page

Verify Installed Options

In the Installed Personalities and Options section on the configuration page, look for options such as hard disk information and DIMM types RAM or ROM and sizes.

Verify that the options installed in the printer are reflected in the configuration page. If an installed device is not shown on the configuration page, see table 7-4 on page 345 for recommended actions.

The Paper Tray and Options section of the configuration page identifies two types of paper handling devices that communicate or interact with the printer:

- Engine DC controller-driven devices
 - Duplexer
 - Envelope Feeder
- Communication Link Devices (C-link protocol)
 - **Input devices:**
 - 2000-sheet Input Tray
 - 2 x 500-sheet Input Tray
 - **Output devices:**
 - 8-bin Multibin Mailbox
 - Multibin Mailbox with Stapler (includes a finisher)
 - 7-bin Tabletop Mailbox

While the engine DC controller-driven devices draw power (24V DC) and control signals from the engine, the C-link devices have their own power supply and controller board.

The information from the paper-handling controller is carried by the C-link cables that connect the controller board of all the C-link protocol supported devices. The C-link protocol supports up to 5 devices connected to the paper handling controller in a daisy chain. Each device controller has an input or output port that provides flexible connections in different configurations. However, it is recommended to use the configuration shown in figure 7-8 on page 346 to avoid rearrangements in the supported device numbering and confusions when evaluating the Event Log.

Table 7-4. Printer Devices Troubleshooting

Device	Action if installed and not detected
Duplexer	Turn the power off, reseal the Duplexer, verify that the connector is not broken, and turn the printer on. If the connector is broken or turning the printer on and off does not work, then replace the duplex cable and/or duplexer.
Envelope Feeder	Turn the power off, reseal the envelope feeder, and turn the printer on. If this does not work, replace the envelope feeder.
Device 1 2000-sheet Input Tray	Verify that the C-link cables are installed correctly (see figure 7-8 on page 346). Remove all C-link connections and visually inspect for connector damage on the cable pins and connector ends.
Device 2 Multibin Mailbox	Try using a different cable to connect the problem device directly to the Paper Handling Controller. All C-link cables are wired the same, but are different lengths.
Device 3 Stapler	If a device is not recognized, replace the device controller or defective C-link cable.
Device 1 2 x 500-sheet and 2000-sheet Input Tray	Verify that AC power is present in the 2000-sheet or 2 x 500-sheet Input Tray. Verify that the C-link cable is connected properly to the Paper Handling Controller or the tray will not lift.
Device 2 7-bin Multibin Mailbox	Verify that the DC power supply is receiving power. Verify that the DC power supply output is connected to the Multibin Mailbox controller. Verify that the C-link cables are properly installed and external power applied. Check if Fuse F202 in the 2 x 500-sheet or 2000-sheet Input Tray's Controller PCA is blown. Replace the DC power supply. Replace the Multibin Mailbox controller.
After verifying that the configuration page accurately reflects the installed devices, proceed to "Image Quality" on page 394.	

Communication

Ask the customer to run a print job from the host system. If the print job is successful, proceed to “Troubleshooting Checks” on page 412.

Interface Troubleshooting

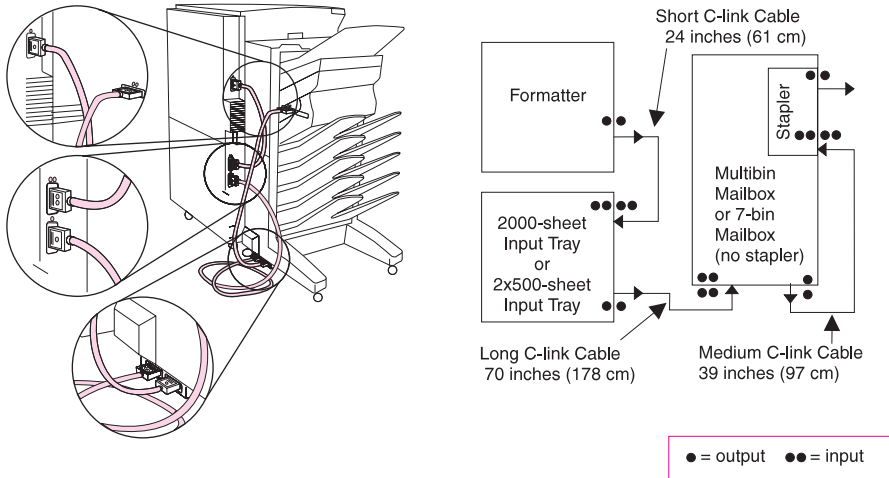

Figure 7-8 Communications Link (C-link) Cables, Supported Daisy Chain Connections

Note If the 7-bin Tabletop Mailbox is sitting on a tabletop instead of on a stand, it is the first device in the daisy chain.

All C-link cables have a single dot molded into the device output connector cable end, and two dots molded into the device input connector cable end.

Note It is important that the C-link cables are installed in the supported daisy chain configuration as shown in figure 7-8. This is so that the devices are recognized and correctly reported on the Event Log.

It is possible, but not recommended, to attach the C-link cables in other configurations. This will rearrange the supported device numbering. Keep this configuration in mind when evaluating the Event Log.

If any of the installed devices are not shown on the configuration page, verify that the C-link cabling is correctly connected and functional (figure 7-8) and that DC power is available to the paper handling devices. Check and reseal suspect cable connections. If any of the cables are replaced, you must cycle the power to have the printer recognize the device again.

Control Panel and Event Log Messages

The format of Control Panel messages is:

- 13.x_y PAPER JAM IN INPUT/OUTPUT DEVICE
- INPUT/OUTPUT DEVICE CONDITION x_y.z_z
- 66.x_y.z_z INPUT/OUTPUT DEVICE FAILURE

The format of Event Log messages is:

- 13.x_y z_z INPUT/OUTPUT DEVICE PAPER JAM
- 65.x_y.z_z INPUT/OUTPUT DEVICE CONDITION
- 66.x_y.z_z INPUT/OUTPUT DEVICE HARDWARE MALFUNCTION

For both the Control Panel and Event Log messages:

- x is the C-link device number in the daisy chain.

x	Description
0	Paper-handling controller
1	First C-link device
2	Second C-link device
3	Third C-link device
4	Fourth C-link device
5	Fifth C-link device

- y is the C-link device type.

y	Description
0	Paper-handling controller
1	Input device
2	Output device
3	Stapler
4	Other supported device (not in use)
5	Other supported device (not in use)

- z_z is the error code. See table 7-5, "Alphabetical Printer Messages," on page 352 and table 7-6, "Numerical Printer Messages," on page 373 for more information.

The following are two examples of Control Panel messages, the corresponding Event Log messages, and what the messages mean. These examples do not show the recommended action to follow to fix the problem. See table 7-5, “Alphabetical Printer Messages,” on page 352 and table 7-6, “Numerical Printer Messages,” on page 373 for the recommended actions for these messages.

Control Panel Message	Event Log Page	Meaning
13.11 PAPER JAM IN INPUT DEVICE	13.11 1B	A paper jam occurred in the first C-link device configured. It is an input device (2000-sheet Input Tray or 2 x 500-sheet Input Tray) with an error code 1B. This is normally a timeout at an entry or exit sensor.
66.22.09 OUTPUT DEVICE FAILURE	66.22.09	A hardware malfunction occurred in the second C-link device configured. It is an output device (Mailbox) with an error code 09. This is an external memory error.

Note

Be sure to print a configuration page to properly identify the input or output device configured. Notice that the error format only identifies the C-link device number and the device type; it does not identify which input or output device is used in the system.

EIO Troubleshooting

The JetDirect Configuration Page shown in figure 7-9 on page 349 contains valuable information about the current status of the EIO accessories. Before attempting to troubleshoot a network problem or notifying your network consultant of a problem, always print a Configuration Page from the Control Panel's Information Menu. If an EIO accessory is installed, the JetDirect Configuration Page prints too.

See the *HP JetDirect Network Interface Configuration Guide* for detailed explanations of network issues.

EIO 3 - JETDIRECT PAGE

JetDirect Configuration Page

Network statistics

GENERAL INFORMATION

HP JETDIRECT	J3113A	NETWORK STATISTICS	
FIRMWARE REVISION:	G.06.00	UNICAST PACKETS RCVD:	399166
LAN HW ADDRESS:	0060B09BC11B	TOTAL PACKETS RCVD:	455443
PORT SELECT:	RJ45	BAD PACKETS RCVD:	587
PORT CONFIG:	10BASE-T HALF	FRAMING ERRORS RCVD:	0
AUTO NEGOTIATION:	ON	PACKETS TRANSMITTED:	397864
MFG ID:	38053805900600	UNSENDABLE PACKETS:	0
		XMIT COLLISIONS:	43428
		XMIT LATE COLLISIONS:	0

I/O card status

PROTOCOL INFORMATION

SNMP SET CMTY NAME:	NONE	APPLETALK STATUS:	READY
TCP/IP STATUS:	READY	ETALK NET:	301 NODE: 004 P2
		APPLETALK NAME:	HP LaserJet 800
		0 Series	
		ETALK ZONE:	ile-tc
HOST NAME:	NP19BC11B	DLC/LLC STATUS:	CONNECTED
CONFIG BY:	DHCP	SERVER ADDRESS:	00805FA97ADE
IP ADDRESS:	205.168.111.43		
SUBNET MASK:	255.255.255.0		
DEF. GATEWAY:	205.168.111.10		
SYSLOG SERVER:	NOT SPECIFIED		
IDLE TIMEOUT (SECONDS):	90		
BOOTP/DHCP SERVER:	205.168.111.2		
CONFIG FILE:	NOT SPECIFIED		
WEBJA SERVER:	NOT SPECIFIED		
IPX/SPX STATUS:	16	IPX/SPX RETRANS:	0
NOT CONFIGURED		NETWORK FRAME TYPE	RCVD
MODE:	QUEUE SERVER	UNKNOWN EN_802.2	346
MODE NAME:		UNKNOWN EN_II	630
NP19BC11B		00003020 EN_802.3	44977

IP address

IPX/SPX status

Node name

Figure 7-9 Sample JetDirect Configuration Page

- If the EIO JetDirect Card has successfully powered up and completed its internal diagnostics, the “I/O CARD READY” message will appear. If communication is lost, an “I/O NOT READY” message appears followed by a two digit error code. Consult the *HP JetDirect Network Interface Configuration Guide* for further details and recommended action.
- The “Network Statistics” column indicates the status of network activity. Bad packets, framing errors, un-sendable packets, and collisions should be minimal. If a high percentage (greater than one percent) of these occur, contact the network administrator. All of the statistics are set to zero when the printer is powered off.
- A “Novell Status” block should state the Novell printer server name to which the printer is connected. If the node name reads “NPIxxxxxx” (xxxxxx = last six digits of the EIO's LAN address), the EIO card has not been configured for a Novell server (as in figure 7-9). This could indicate that the card is operating under an IPX protocol other than Novell. Consult with the network administrator if the Node Name is not present.
- In the TCP/IP protocol block, the default IP address is “192.0.0.192.” It is acceptable to operate the printer with this default address. The error message, “ARP DUPLICATE IP ADDRESS” may appear in this block. This is also an acceptable error code if the TCP/IP protocol is not being used. Please check with the network administrator to determine the correct IP address for the printer.

Verify Host System Operation

Try to print to another known working printer or move the failing printer to a known working location. Verify that the correct driver is installed and operating properly.

Verify Network and Server Operation

- Try to print the job to the printer's parallel port.
- Try to print from the host system through the network to another printer. Contact the network administrator for assistance.

Printer Messages

Control Panel Messages and Errors

Printer messages displayed on the control panel provide five categories of information. Each message category is assigned a priority. If more than one condition occurs at the same time, the highest priority message is displayed. When it has been cleared, the next priority message will be displayed, and so on. The displayed messages and their priorities are:

- Status messages
- Warning messages
- Error messages
- Critical error messages

Event Log Table

Note

All of the alphabetical messages are listed first. Numeric messages are listed in table 7-6 on page 373. The Event Log codes (the second column) are in no order. They are merely listed with the associated display panel message.

Table 7-5. Alphabetical Printer Messages

Message	Event Log Category/ Message	Description	Recommended Action
ACCESS DENIED MENUS LOCKED	Status	The printer control panel function you are trying to access has been locked to prevent unauthorized access.	Ask the network administrator to unlock the function.
BAD DUPLEXER CONNECTION	Error	The duplexer is not connected properly.	<ol style="list-style-type: none">1. Re-install the duplexer.2. If the message persists, make sure the duplexer is connected and the connector is not damaged.3. Replace the duplexer. See "Duplexer" on page 149 for instructions.
BAD OPT TRAY CONNECTION	Error	The optional tray is not connected properly.	<ol style="list-style-type: none">1. Re-install the optional tray.2. Make sure the optional tray is connected and the connector is not damaged.3. Replace the optional tray.
CANCELING JOB	Status	The printer is canceling the active job.	No action is required. If the message displays for over five minutes, turn the printer off, and then turn the printer on. A large print job with detailed graphics might take up to five minutes to cancel.

Table 7-5. Alphabetical Printer Messages (continued)

Message	Event Log Category/Message	Description	Recommended Action
CHECK FINISHER DEVICE alternates with CLEAR JAM	Error	A stapler jam or a paper jam in the occurred.	<ol style="list-style-type: none"> 1. Clear the paper from the stapler. 2. Open the top cover of the stapler and clear the stapler jam. 3. Resend the print job.
CHECK FINISHER DEVICE alternates with FINISHER ALIGN ERROR	Error	The paper is not aligned correctly in the stapler.	<ol style="list-style-type: none"> 1. Remove the paper from the stapler. 2. Resend the print job.
CHECK INPUT DEVICE alternates with PAPER PATH OPEN PLEASE CLOSE IT	Error	The optional input tray cannot feed paper to the printer because a door or paper guide is open.	Check the doors and paper guides.
CHECK OUTPUT DEVICE alternates with CLOSE OUTPUT DELIVERY PATH	Error	The paper path between the printer and the external paper handling output device is open and must be closed before printing can continue.	Close the paper path.
CHECKING PAPER PATH	Error	The engine is advancing its rollers to check for possible paper jams.	Stand by. If the message does not clear, turn the printer off, and then turn the printer on.
CHOSEN LANGUAGE NOT AVAILABLE	Warning	A print job requested a printer language that does not exist in the printer. The job will not print and will be cleared from memory.	<ol style="list-style-type: none"> 1. Print the job using a driver for a different printer language, or add the requested language to the printer (if available). 2. Press Go to continue.

Table 7-5. Alphabetical Printer Messages (continued)

Message	Event Log Category/Message	Description	Recommended Action
CLEARING PAPER FROM PRINTER	Status	The printer is attempting to remove unusable paper. This might occur after you clear a paper jam.	No action is required.
CLOSE TOP COVER OR SIDE DOORS	Error	Displays when any door is open.	Close the top cover or side doors.
DATA RECEIVED	Status	Displays when the received data is waiting for a form feed.	No action required.
DISK DEVICE FAILURE	Warning	The EIO disk had a critical failure and can no longer be used.	Remove the EIO disk, and replace it with a new one.
DISK FILE OPERATION FAILED	Warning	The requested operation could not be performed. You might have attempted an illegal operation, such as trying to download a file to a non-existent directory.	<ol style="list-style-type: none">1. Check the filename and directory name.2. Reattempt the operation.
DISK FILE SYSTEM IS FULL	Warning	The disk is full.	<ol style="list-style-type: none">1. Delete files from the EIO disk and then try again, or add a flash DIMM.2. Download or delete files from HP JetAdmin, and download or delete fonts from HP FontSmart. (See the software help for more information.)
DISK IS WRITE PROTECTED	Warning	The EIO disk is protected, and no new files can be written to it.	Disable the write protection through HP JetAdmin.

Table 7-5. Alphabetical Printer Messages (continued)

Message	Event Log Category/Message	Description	Recommended Action
DUPLEX ERROR CHECK DUPLEXER	Error	The duplexer has an error.	<ol style="list-style-type: none">1. Remove the paper jam.2. Reseat the Duplex Assembly, and check the connection.3. If necessary, replace the Duplexer. See "Duplexer" on page 149 for instructions.
EIO x DISK INITIALIZING	Status	The EIO disk device in slot x is initializing.	No action required.
EIO x DISK SPINNING UP	Status	The EIO disk device in slot x is spinning up its platter.	The disk accessory card takes a long time to initialize. The first parameter is the accessory slot number for this accessory card.
EIO DISK x NON-FUNCTIONAL	Error	The EIO disk is not working correctly.	Replace the EIO disk.
ENV FEEDER LOAD [SIZE]	Error	The envelope feeder does not have the requested paper.	Put the requested paper in the envelope feeder.

Table 7-5. Alphabetical Printer Messages (continued)

Message	Event Log Category/ Message	Description	Recommended Action
ENV FEEDER LOAD [TYPE] [SIZE]	Error	There is no envelope in the feeder, the wrong size is loaded in the feeder, or the type and size is set incorrectly in the control panel.	<ol style="list-style-type: none"> 1. Load the requested envelope type and size into the envelope feeder. 2. Make sure that the envelope size and type are set correctly from the Paper Handling Menu in the printer's control panel. 3. Press Go if the desired envelope is already loaded in the feeder. 4. Press - VALUE + to scroll through the available types and sizes. 5. Press SELECT to accept the alternate type or size.
ENVELOPE FEEDER EMPTY	Warning	The envelope feeder is empty. Printing of the current job is not interrupted.	Refill the envelope feeder.
EVENT LOG EMPTY	Error	Displays when the user tries to view an empty Event Log by selecting SHOW EVENT LOG from the control panel.	No action required.
EXTERNAL DEVICE INITIALIZING	Status	When an external paper handling device is connected to the printer, it must have 10 seconds to initialize after boot or after coming out of PowerSave mode.	No action required.
FINISHER LOW ON FINISHING AGENT	Warning	The finishing device is running out of its finishing material.	Refill the finishing device.

Table 7-5. Alphabetical Printer Messages (continued)

Message	Event Log Category/Message	Description	Recommended Action
FINISHER OUT OF BINDING AGENT	Error	The external paper handling finisher device is out of binding agent.	Refill the finishing device.
FLASH DEVICE FAILURE	Warning	The flash DIMM had a critical failure and can no longer be used.	Remove the flash DIMM, and replace it with a new one. See "Memory and Personality Upgrade" on page 147 for instructions.
FLASH DISK x INITIALIZING alternates with DO NOT POWER OFF	Status	The new flash DIMM installed in slot x is initializing.	No action required.
FLASH FILE OPERATION FAILED	Warning	The requested operation could not be performed. You might have attempted an illegal operation, such as trying to download a file to a non-existent directory.	<ol style="list-style-type: none">1. Check the filename and directory name.2. Reattempt the operation.
FLASH FILE SYSTEM IS FULL	Warning	The flash DIMM is full.	<ol style="list-style-type: none">1. Delete files from the flash DIMM, or add another DIMM. See "Memory and Personality Upgrade" on page 147 for instructions.2. Download or delete files from HP JetAdmin, and download or delete fonts from HP FontSmart. (See the software help for more information.)
FLASH IS WRITE PROTECTED	Warning	The flash DIMM is protected, and no new files can be written to it.	Disable the write protection through HP JetAdmin.

Table 7-5. Alphabetical Printer Messages (continued)

Message	Event Log Category/Message	Description	Recommended Action
INITIALIZING	Status	If this message displays continually, a DIMM may not be inserted completely.	Reseat the DIMM(s).
INPUT DEVICE CONDITION 11.01	65.11.01	The detected cassette in the 2000-sheet or 2 x 500-sheet Input Tray is not consistent with the paper size specified by the paper-handling controller.	<ol style="list-style-type: none">1. Make sure the size, source, and type of paper selected from the software configuration is correct.2. Pull the tray out and make sure the size and type of paper loaded matches the size and type specified in the software configuration.
INPUT DEVICE CONDITION 11.04	65.11.04	Tray 3 or Tray 4 is specified by the paper-handling controller.	<ol style="list-style-type: none">1. Make sure the size, source, and type of paper selected from the software configuration is correct.2. Pull the tray out and make sure the size and type of paper loaded matches the size and type specified in the software configuration.
INPUT DEVICE CONDITION 11.06	65.11.06	Tray 3 or Tray 4 received a request to feed more than 4 pages at a time.	<ol style="list-style-type: none">1. Make sure the size, source, and type of paper selected from the software configuration is correct.2. Pull the tray out and make sure the size and type of paper loaded matches the size and type specified in the software configuration.
INSTALL DUPLEXER	Error	The duplexer has been pulled out.	Re-insert the duplexer.

Table 7-5. Alphabetical Printer Messages (continued)

Message	Event Log Category/Message	Description	Recommended Action
INSTALL TONER CARTRIDGE	Error	The toner cartridge is missing.	Re-install the toner cartridge.
LOADING PROGRAM X alternates with DO NOT POWER OFF	Status	Programs and fonts can be stored on the printer's file system. At bootup time these entities are loaded into RAM. (These entities can take a long time to load into RAM depending on the size and number of entities being loaded.) The X specifies a sequence number indicating the current program being loaded.	Wait for the program to load.
MANUALLY FEED [SIZE]	Error	Tray 1 does not contain the specified size paper.	Load the specified type of paper into Tray 1.
MANUALLY FEED TRAY 1 ENVELOPE	Error	Tray 1 does not contain an envelope.	Load an envelope into Tray 1.
MANUALLY FEED [TYPE] ENV	Error	Tray 1 does not contain the specified type of envelope.	Load the specified type of envelope into Tray 1.
MANUALLY FEED [TYPE] [SIZE]	Error	One of the following occurred: <ul style="list-style-type: none"> • A manual feed was requested. • There is no paper in Tray 1. • The wrong size paper is loaded. • The control panel is not set for the kind of paper loaded. 	<ol style="list-style-type: none"> 1. Load the requested paper into Tray 1. 2. Press Go if the desired paper is already loaded in Tray 1. 3. Press - VALUE + to scroll through the available types and sizes. 4. Press SELECT to accept the alternate type or size.

Table 7-5. Alphabetical Printer Messages (continued)

Message	Event Log Category/Message	Description	Recommended Action
MEMORY FULL STORED DATA LOST	Error	There is no available memory in the printer. The current job might not print correctly and some resources (such as downloaded fonts or macros) might have been deleted.	You might want to add more memory to the printer, or simplify the print job. See “Memory and Personality Upgrade” on page 147 for instructions.
MEMORY SETTINGS CHANGED	Error	The printer changed its memory settings because it did not have enough memory to use the previous settings for I/O Buffering and Resource Saving. This usually occurs after removing memory from the printer, adding a duplexer, or adding a printer language.	You might want to change memory settings for I/O Buffering and Resource Saving (although default settings are usually best) or add more memory to the printer.
MEMORY SHORTAGE JOB CLEARED	Warning	The printer did not have enough free memory to print the entire job. The remainder of the job will not print and will be cleared from memory.	1. Press Go to continue. 2. Change the Resource Saving setting from the printer’s control panel, or add more memory to the printer. See “Memory and Personality Upgrade” on page 147 for instructions.
MEMORY SHORTAGE PAGE SIMPLIFIED	Warning	The printer had to compress the job in order to fit it in available memory. Some data loss might have occurred.	1. Press Go to continue. 2. You might want to add more memory to the printer. See “Memory and Personality Upgrade” on page 147 for instructions.

Table 7-5. Alphabetical Printer Messages (continued)

Message	Event Log Category/Message	Description	Recommended Action
NO JOB TO CANCEL	Status	Displays when you press the CANCEL JOB key and there is no active job or buffered data to cancel. This displays for approximately 2.5 seconds before the printer returns to the online READY state.	No action required.
OFFLINE	Status	Displays when the printer is offline and there are no error messages pending at the display.	Press Go to place the printer online.
OUTPUT BIN FULL alternates with CLEAR PAPER FROM [BINNAME]	Error	The output bin is full and needs to be emptied.	<ol style="list-style-type: none"> 1. Remove the media from the standard output bin. 2. Check PS1401 on the sensor PCA. 3. Make sure that the sensor flag moves freely.
OUTPUT DEVICE CONDITION 22.01	65.22.01	The left output bin is too full.	<ol style="list-style-type: none"> 1. Empty the left output bin. 2. Make sure that the sensor flag moves freely. 3. If the problem persists, check for proper cable connection in the flipper area. 4. If the problem persists, replace the Flipper Assembly. See "Flipper Assembly" on page 227 for instructions. 5. Replace the Mailbox Controller PCA. See the <i>HP LaserJet 8000, 8000 N, 8000 DN, and HP Mopier 240 Printers Service Manual Supplement for Paper-handling Accessories</i> for instructions.

Table 7-5. Alphabetical Printer Messages (continued)

Message	Event Log Category/Message	Description	Recommended Action
OUTPUT DEVICE CONDITION 22.02 22.03 22.04	65.22.02 65.22.03 65.22.04	An elevator problem home not found, elevator problem scanning bins error, or slider jam occurred in the Multibin Mailbox.	<ol style="list-style-type: none"> 1. Make sure that the blind cover and scan bar are installed properly. 2. Check for paper jam in the delivery head assembly. 3. Make sure that the delivery head assembly moves freely. 4. Make sure that all the paper bins are seated correctly. 5. Make sure that the paper bins and blind covers are not broken. 6. Perform a paper path test. See "Paper Path Test" on page 415. 7. Check for damaged sensors in the delivery head assembly. 8. Check the fingers in the head assembly. They must be over the ejector rollers. 9. Replace the delivery head assembly. See the <i>HP LaserJet 8000, 8000 N, 8000 DN, and HP Mopier 240 Printers Service Manual Supplement for Paper-handling Accessories</i> for instructions. 10. Replace the delivery head motor. See the <i>Service Manual Supplement for Paper-handling Accessories</i> for instructions. 11. Replace the Mailbox Controller PCA. See the <i>Service Manual Supplement for Paper-handling Accessories</i> for instructions.

Table 7-5. Alphabetical Printer Messages (continued)

Message	Event Log Category/Message	Description	Recommended Action
PERFORM PRINTER MAINTENANCE	Warning	To ensure optimum print quality, the printer prompts you to perform routine maintenance every 350,000 pages.	Install the Printer Maintenance Kit. You must reset the maintenance page count after performing maintenance by pressing ITEM- and VALUE- while turning the printer on.
PLEASE WAIT	Status	The printer is in the process of emptying data so it can go offline or go into the menus.	No action required.
POWERSAVE ON	Status	The printer is in PowerSave mode.	This message is cleared when an error condition occurs, the printer receives printable data, or you press any key.
PRINTING CONFIGURATION	Status	The configuration page is printing. The printer returns to the online READY state when the printing is completed.	No action required.
PRINTING ENGINE TEST	Status	An engine self test is printing. The printer returns to the READY state, but remains offline when printing is completed.	No action required.
PRINTING EVENT LOG	Status	The Event Log is printing. The printer returns to the online READY state when printing is completed.	No action required.
PRINTING FILE DIRECTORY	Status	The mass storage directory page is printing. The printer returns to the online READY state when printing is completed.	No action required.

Table 7-5. Alphabetical Printer Messages (continued)

Message	Event Log Category/ Message	Description	Recommended Action
PRINTING FONT LIST	Status	The PCL or PS personality typeface list is printing. The printer returns to the online READY state when printing is completed.	No action required.
PRINTING MENU MAP	Status	The menu map is printing. The printer returns to the online READY state when printing is completed.	No action required.
PRINTING PAPER PATH TEST	Status	A paper path test is printing. The printer returns to the online READY state when printing is completed.	No action required.
PROCESSING COPY X OF Y	Status	The printer is processing or printing collated copies. Copy X of Y total copies is being processed.	No action required.
PROCESSING JOB	Status	The printer is processing the current job, but has not started picking pages. When paper movement begins, this message is replaced by a PROCESSING JOB message that indicates which tray the job is being printed from.	No action required.
PROCESSING JOB FROM ENV FEEDER	Status	The printer is printing from the envelope feeder.	No action required.

Table 7-5. Alphabetical Printer Messages (continued)

Message	Event Log Category/Message	Description	Recommended Action
PROCESSING JOB FROM TRAY x	Status	The printer is processing a job.	<p>If an incorrect tray is displayed, check the tray selected and the type settings. If the printer does not respond after pressing the control panel keys, turn the printer off, and then turn the printer on to clear the error.</p> <p>Note: If paper is loaded when the printer is in POWERSAVE ON mode, it might not be recognized. Open and close the affected source when the printer is in READY mode.</p>
RAM DISK DEVICE FAILURE	Warning	The RAM disk had a critical failure and can no longer be used.	<ol style="list-style-type: none"> 1. Turn the printer off, and then turn the printer on to clear the message. 2. If the message persists, install a new RAM disk.
RAM DISK FILE OPERATION FAILED	Warning	The requested operation could not be performed. You might have attempted an illegal operation, such as trying to download a file to a non-existent directory.	<ol style="list-style-type: none"> 1. Check the filename and directory name. 2. Reattempt the operation.

Table 7-5. Alphabetical Printer Messages (continued)

Message	Event Log Category/Message	Description	Recommended Action
RAM DISK FILE SYSTEM IS FULL	Warning	The RAM disk is full.	<ol style="list-style-type: none">1. Delete files and then try again, or turn the printer off and then turn the printer on to delete all the files on the device. (Delete files using HP JetAdmin, HP FontSmart, or another software utility. See the software help for more information.)2. If the message persists, increase the size of the RAM disk. Change the RAM disk size from the Configuration Menu in the printer's control panel.
RAM DISK IS WRITE PROTECTED	Warning	The RAM disk file is protected, and no new files can be written to it.	Disable the write protection through HP JetAdmin.
READY	Status	The printer is online and ready for data. No status or device attendance messages are pending at the display.	No action required.
REINSERT DUPLEXER	Error	The duplexer has been pulled out.	Re-insert the duplexer.
REQUEST ACCEPTED PLEASE WAIT	Status	A request to print an internal page has been accepted, but cannot be printed now.	No action required. When the current print job is done, the internal page will print.

Table 7-5. Alphabetical Printer Messages (continued)

Message	Event Log Category/Message	Description	Recommended Action
RESETTING ACTIVE I/O CHANNEL	Status	Displays during an active I/O reset from the control panel. When the reset is completed, the printer returns to the ready state and automatically goes online.	No action required.
RESETTING ALL I/O CHANNELS	Status	Displays during an all I/O reset from the control panel. When the reset is completed, the printer returns to the ready state and automatically goes online.	No action required.
RESETTING MEMORY	Status	Displays during a reset from the control panel. When the reset is completed, the printer returns to the ready state and automatically goes online.	No action required.
RESTORING FACTORY SETTINGS	Status	Displays during a RESTORE FACTORY SETTINGS printer reset and a COLD RESET.	No action required.
SERVICE MODE	Status	The printer is in service or maintenance mode.	No action required.
STAPLER LOW ON STAPLES	Warning	The stapler device is running out of staples.	Refill the stapler device.
STAPLER OUT OF STAPLES	Warning	The external paper handling stapler device is out of staples.	Refill the stapler device.

Table 7-5. Alphabetical Printer Messages (continued)

Message	Event Log Category/ Message	Description	Recommended Action
TONER LOW	Warning	The TONER LOW setting in the Configuration Menu is set to CONTINUE and a low toner situation is encountered.	Remove and shake the toner cartridge to distribute the toner. The toner cartridge should print approximately 200 pages after the first message.
TONER LOW alternates with PRESS GO TO CONTINUE	Error	The TONER LOW setting in the Configuration Menu is set to STOP and a low toner situation is encountered.	No action required. Once this message is overridden either by the printer automatically continuing past it or by the user pressing Go, it is then treated as a clearable warning.
TOO MANY PAGES IN JOB TO STAPLE	Warning	The external paper handling stapler device received too many pages to staple. The pages will be ejected unstapled.	Staple the pages manually.
TRAY X CONTAINS UNKNOWN MEDIA	Warning	The media type in the specified tray cannot be determined.	Load known media, or set the correct media type.

Table 7-5. Alphabetical Printer Messages (continued)

Message	Event Log Category/Message	Description	Recommended Action
TRAY X EMPTY	Warning	The paper tray is empty. Paper is sensed in the tray by black plastic flags and photosensors. If paper is not in a tray, the flags will rotate through an access in the upper tray. When paper is present, the flags are blocked from rotating through this access.	<ol style="list-style-type: none">1. Load the empty tray (X) to clear the message. If you do not load the specified tray, the printer will continue printing from the next available tray, and the message will continue to display.2. Make sure that the paper out flag is not stuck in the down position by rough media. Do this before opening the tray. To check this flag without opening Tray 2, remove the Duplexer if it is present.3. Open the Front Access Door. This provides you with a clear view of the Tray 2 paper out sensor flag. To check this flag without opening Tray 3, use a flashlight to observe the paper out flag. If either paper flag is damaged, replace the paper flag or the paper input tray. If the printer is using Tray 2 or 3 and the message is accompanied by a clicking noise every few seconds, replace the Paper Input Unit Assembly. See "Paper Input Unit (PIU)" on page 195 for instructions.

Table 7-5. Alphabetical Printer Messages (continued)

Message	Event Log Category/Message	Description	Recommended Action
TRAY X LIFTING	Error	Displays when tray X is in the process of lifting the paper to the top of the tray for proper feeding.	<ol style="list-style-type: none"> 1. If the message does not go away, verify that the media can be pulled from another tray. 2. The Paper Input Unit may need to be replaced. See "Paper Input Unit (PIU)" on page 195 for instructions.
TRAY XX LOAD [SIZE]	Error	Tray X does not contain the specified size of paper.	Load the specified size of paper into Tray X.
TRAY xx LOAD [TYPE] [SIZE]	Error	<p>One of the following occurred:</p> <ul style="list-style-type: none"> • There is no paper loaded in the specified tray, or the paper is not the size requested, or the control panel is not set for the size of paper loaded. • The tray is not properly adjusted for size. • The default paper size is set incorrectly. • If this message appears and the tray contains the correct size of paper, a sensor could be damaged or a paper sensor lever could be stuck. 	<ol style="list-style-type: none"> 1. Load the requested paper into the specified tray (x). Make sure that the trays are correctly adjusted for size. The tray type settings (and size for Tray 1) must be set from the printer's control panel. If you are trying to print A4 or letter size paper and this message appears, make sure that the default paper size is set correctly from the Printing Menu in the printer's control panel. 2. Press Go to print from the next available tray. 3. Press - VALUE + to scroll through the available types and sizes. 4. Press SELECT to accept the alternate type or size. 5. Inspect the switches in the tray. 6. Turn the printer on with the tray removed and push the switches by hand to see if they register.

Table 7-5. Alphabetical Printer Messages (continued)

Message	Event Log Category/ Message	Description	Recommended Action
TRAY X OPEN	Warning	The specified tray is open.	Close the tray to continue.
TRAY XX LOAD [SIZE]	Error	Tray X does not contain the specified size of paper.	Load the requested paper into the indicated tray, or press SELECT to override the message and to print on a loaded paper size.
UNABLE TO MOPY JOB	Error	Memory or file system failures would not allow a mopy job to occur. Either the printer is not configured to mopy or there is inadequate printer RAM (disk) memory. Inadequate available RAM disk is a result of insufficient memory configured (8 MB) or the print job exceeded the available configured memory, including the on-board disk. Only one copy will be produced.	<ol style="list-style-type: none"> 1. Check to see if mopying is turned on. Turn mopying on through the available control panel steps. 2. Configure a minimum of 8 MB RAM disk. 3. Make sure that there is adequate available printer DIMM memory or hard disk space. The available space should exceed the size of the print job. (You can print the job to a file on your PC and compare that with the available printer memory or hard disk space available.)
UNSUPPORTED SIZE IN TRAY [YY]	Error	An external paper handling device detected an unsupported paper size. The printer will go offline until the condition is corrected.	Load a supported paper size in the tray.
USE [TYPE] [SIZE] INSTEAD?	Error	If the requested paper size or type is not available, the printer asks if it should use another paper size or type instead.	<ol style="list-style-type: none"> 1. Press - VALUE + to scroll through the available types and sizes. 2. Press SELECT to accept the alternate type or size.

Table 7-5. Alphabetical Printer Messages (continued)

Message	Event Log Category/ Message	Description	Recommended Action
WAIT FOR PRINTER TO REINITIALIZE	Status	The RAM disk setting has been changed from the printer's control panel. This change will not take effect until the printer reinitializes.	Wait for the printer to reinitialize. If you change the mode of the external device, turn the printer off, turn the printer on, and wait for the printer to reinitialize.
WARMING UP	Error	The printer fuser is heating up, and printing will continue as soon as it is done.	No action is required.
WRONG ENVELOPE FEEDER INSTALLED	Error	The envelope feeder you are trying to install will not work for this printer.	Install the correct envelope feeder.

The following is an example of the format for numerical control panel messages.

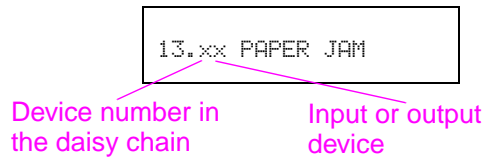

Table 7-6. Numerical Printer Messages

Message	Event Log Category/ Message	Description	Recommended Action
XX.YY PRINTER ERROR PRESS GO TO CONTINUE	Error	A printer error has occurred.	Press Go in the printer's control panel to clear the error message.
13.xx PAPER JAM CHECK FRONT DOOR alternates with THEN OPEN AND CLOSE TOP COVER	Error	A page is jammed.	Check the front door of the printer. Opening and closing the top cover will cause the printer to go back online.
13.xx PAPER JAM CHECK LEFT DOOR	Error	A page is jammed.	Check the left door of the printer.
13.xx PAPER JAM CHECK RIGHT DOOR alternates with THEN OPEN AND CLOSE TOP COVER	Error	A page is jammed.	Check the right door of the printer. Opening and closing the top cover will cause the printer to go back online.

Table 7-6. Numerical Printer Messages (continued)

Message	Event Log Category/Message	Description	Recommended Action
13.×× PAPER JAM CHECK TOP BIN alternates with THEN OPEN AND CLOSE TOP COVER	Error	A page is jammed.	Check the standard output bin. Opening and closing the top cover will cause the printer to go back online.
13.×× PAPER JAM OPEN TOP COVER alternates with CHECK UNDER TONER CARTRIDGE	Error	A page is jammed.	Check underneath the toner cartridge for the jammed page.
13.yz PAPER JAM IN INPUT DEVICE alternates with CHECK TRAY X AND RIGHT DOOR	Error	Paper is jammed in tray X.	<ol style="list-style-type: none"> 1. Remove the jammed paper from the specified location. 2. Open and close the top cover to clear the message. If the message persists after all jams have been cleared, a sensor might be stuck or broken.
13.1	13.1 0B	Did not receive paper from the Duplexer.	<ol style="list-style-type: none"> 1. Open the front door, and remove any paper. 2. Open the right door, and remove any paper. 3. Remove any paper from the Duplexer. 4. Make sure that paper is being delivered to the Duplexer. 5. Replace the Duplexer if necessary. See “Duplexer” on page 149 for instructions.

Table 7-6. Numerical Printer Messages (continued)

Message	Event Log Category/ Message	Description	Recommended Action
13.1	13.1 16	A page stayed too long at the Duplexer's second sensor.	<ol style="list-style-type: none"> 1. Open the top cover, and remove any paper. 2. Open the left and right doors, and remove any paper. 3. Remove the paper from the Duplexer. 4. Make sure that paper is being delivered to the Duplexer. 5. Replace the Duplexer if necessary. See "Duplexer" on page 149 for instructions.
13.1	13.1 1F	A page stayed too long on the Duplexer's second sensor.	<ol style="list-style-type: none"> 1. Open the top cover, and remove any paper. 2. Open the front, left, and right doors, and remove any paper. 3. Remove the paper from the Duplexer. 4. Make sure that paper is being delivered to the Duplexer. 5. Replace the Duplexer if necessary. See "Duplexer" on page 149 for instructions.
13.1 PAPER JAM CHECK RIGHT DOOR	13.1 XX	Paper feed 1, paper late jam. Paper did not reach PS2.	Use the Paper Path Test on page 415 to see if a problem exists from both engine trays. If PS2 is bad, it will fail when printing from Tray 2 or 3. Verify flag movement by manually inserting paper in the sensor path. Replace PS2 or the Paper Input Unit (PIU) Assembly. See "Paper Input Unit (PIU)" on page 195 for instructions.

Table 7-6. Numerical Printer Messages (continued)

Message	Event Log Category/Message	Description	Recommended Action
13.1Y PAPER JAM IN INPUT DEVICE alternates with CHECK TRAY Z AND RIGHT DOOR	Error	A page is jammed in an external paper handling device. Y is the device number Z is the tray number	Check the specified tray.
13.3 PAPER JAM CHECK RIGHT DOOR alternates with THEN OPEN AND CLOSE TOP COVER	13.3 XX	Paper delay jam. Paper did not reach PS1 at the registration area.	<ol style="list-style-type: none"> 1. Remove the toner cartridge, lift the green handle, and verify the sensor flag operation. 2. Make sure that the sensor is not broken. 3. Replace the registration assembly if necessary. See "Registration Assembly" on page 207 for instructions.
13.5 FUSER OUTPUT, PAPER STOPPED JAM	13.5 XX	Fuser output, paper late jam. Paper never reached PS1403 at the fusing assembly.	Remove the toner cartridge, and check the path between the registration and fusing assemblies. PS1403 on the sensor PCA may be faulty.
13.6 FUSER OUTPUT PAPER STOPPED JAM	13.6 XX	Fuser output, paper stopped jam. Paper never exited the fusing assembly.	<ol style="list-style-type: none"> 1. Check the fuser flag at the sensor board area. 2. Check the fuser access door. 3. Make sure that the flag is not broken. PS1403 on the sensor PCA may be faulty.
13.9 CHECK LEFT DOOR	13.9 XX	Standard output bin paper late jam.	Paper did not arrive at PS1402 when expected. Inspect the path between the fuser and delivery assemblies. Check the diverter assembly.

Table 7-6. Numerical Printer Messages (continued)

Message	Event Log Category/ Message	Description	Recommended Action
13.A PAPER JAM CHECK LEFT DOOR	13.A XX	Paper stopped at the standard output bin.	Check the paper path. This jam is sensed by PS2401 on the sensor PCA.
13.10	13.10 15	A page did not arrive at the Duplexer's first sensor.	<ol style="list-style-type: none">1. Open the top cover, and remove any paper.2. Open the left door, and remove any paper.3. Remove the paper from the Duplexer.4. Make sure that paper is being delivered to the Duplexer.5. Replace the Duplexer if necessary. See "Duplexer" on page 149 for instructions
13.10 PAPER JAM	13.10 XX	Duplex turnaround, paper late jam. The paper did not reach the duplex turnaround when it should have.	<ol style="list-style-type: none">1. Check the duplexer and the left door area for obstructions.2. Reseat the duplexer.3. Replace the duplexer if necessary. See "Duplexer" on page 149 for instructions.
13.11	13.11 04	A page stayed too long at the Duplexer's first sensor.	<ol style="list-style-type: none">1. Open the left door, and remove any paper.2. Remove the paper from the Duplexer.3. Make sure that paper is being delivered to the Duplexer.4. Replace the Duplexer if necessary. See "Duplexer" on page 149 for instructions.

Table 7-6. Numerical Printer Messages (continued)

Message	Event Log Category/Message	Description	Recommended Action
13.11 PAPER JAM	13.11 XX	Duplex turnaround, paper stopped jam. Paper is jammed in the duplex assembly.	<ol style="list-style-type: none"> 1. Check the entire paper path. 2. Reseat the duplexer. 3. Use the Paper Path Test on page 415. 4. Replace the duplexer if necessary. See “Duplexer” on page 149 for instructions.
13.11 PAPER JAM IN INPUT DEVICE	13.11 11 13.11 1B 13.11 21 13.11 2B 13.11 31 13.11 3B	Timeout at the Entry or Exit sensor on the 2000-sheet or 2 x 500-sheet Input Tray.	<ol style="list-style-type: none"> 1. Open the Vertical Transfer Unit (VTU), and remove the media. 2. Make sure that the Entry or Exit sensor can move freely. 3. If the problem persists, open the VTU and override its OpenDoor sensor, perform a Paper Path Test from the 2000-sheet or 2 x 500-sheet Input tray (see “Paper Path Test” on page 415), and make sure the feed rollers are advancing the paper. 4. If the rollers do not rotate, verify the connections at the Main Drive Assembly, Pickup Assembly, Controller PCA, and Power Supply. If the rollers still do not rotate or do not drop down, replace the Pickup Assembly. 5. If the rollers rotate and drop down, but do not advance the paper, replace the feed rollers using the Maintenance Kit. 6. If the problem persists, replace the VTU.

Table 7-6. Numerical Printer Messages (continued)

Message	Event Log Category/ Message	Description	Recommended Action
13.12	13.12 0D	A page did not arrive at the Duplexer's second sensor.	<ol style="list-style-type: none"> 1. Open the front and left doors, and remove any paper. 2. Remove the paper from the Duplexer. 3. Make sure that paper is being delivered to the Duplexer. 4. Replace the Duplexer if necessary. See "Duplexer" on page 149 for instructions.
13.12 PAPER JAM IN OUTPUT DEVICE	13.12 01 13.12 11 13.12 12 13.12 15 13.12 17 13.12 21 13.12 22 13.12 25 13.12 27 13.12 31 13.12 32 13.12 35 13.12 37	<p>One of the following occurred on the 7-bin Tabletop Mailbox:</p> <ul style="list-style-type: none"> • An unexpected page at the entry sensor. • The page did not reach the entry sensor, paper path sensor 1, paper path sensor 2, or the left output bin delivery sensor on time. • The page stayed at the entry sensor, paper path sensor 1, paper path sensor 2, or left output bin delivery sensor. • A page was found at the entry sensor, paper path sensor 1, paper path sensor 2, or left output delivery sensor during the power-on sequence. 	<ol style="list-style-type: none"> 1. Remove the media from the paper path. 2. If the problem persists, perform the Paper Path Test on page 415. 3. If any delivery rollers are damaged, replace them. 4. If the problem persists, perform the sensor test. Replace any sensor that is damaged or the sensor PCA board. 5. If the problem persists, perform the motor test to check the solenoids and motors. Replace any motor or solenoid that is damaged. 6. If the problem persists and all sensors, motors, delivery rollers, and the solenoid are working properly, replace the 7-bin Tabletop Mailbox Controller PCA. See "7-bin Tabletop Mailbox Controller PCA" on page 269 for instructions.

Table 7-6. Numerical Printer Messages (continued)

Message	Event Log Category/ Message	Description	Recommended Action
13.12 PAPER JAM	13.12 XX	Duplex path, paper late jam. Paper did not arrive when expected.	<ol style="list-style-type: none">1. Check the paper path between the fuser and duplex assembly.2. Reseat the duplex assembly.3. Replace the duplexer if necessary. See "Duplexer" on page 149 for instructions.
13.13 PAPER JAM	13.13 XX	Duplex path, paper stopped jam. Paper is jammed in the duplex assembly.	<ol style="list-style-type: none">1. Check the entire paper path.2. Remove the duplex assembly and look for paper in the side of the assembly.3. Retest.4. Replace the duplexer if necessary. See "Duplexer" on page 149 for instructions.
13.20	13.20 08	When clearing the paper path, the Duplexer's sensor stayed active too long.	<ol style="list-style-type: none">1. Open the front door, and remove any paper.2. Remove the paper from the Duplexer.3. Make sure that paper is being delivered to the Duplexer.4. Replace the Duplexer if necessary. See "Duplexer" on page 149 for instructions.
13.20 PAPER JAM CHECK LEFT DOOR	13.20 XX	The engine could not eject a page in the printer. The front panel message will indicate the sensor closest to the paper.	Remove the jam from the location indicated on the control panel.

Table 7-6. Numerical Printer Messages (continued)

Message	Event Log Category/Message	Description	Recommended Action
13.22 PAPER JAM IN OUTPUT DEVICE	13.22 01 13.22 11 13.22 12 13.22 15 13.22 17 13.22 21 13.22 22 13.22 25 13.22 27 13.22 31 13.22 32 13.22 35 13.22 37	<p>One of the following occurred on the 7-bin Tabletop Mailbox:</p> <ul style="list-style-type: none"> • An unexpected page at the entry sensor. • The page did not reach the entry sensor, paper path sensor 1, paper path sensor 2, or left output bin delivery sensor on time. • The page stayed at the entry sensor, paper path sensor 1, paper path sensor 2, or left output bin delivery sensor. • A page was found at the entry sensor, paper path sensor 1, paper path sensor 2, or left output delivery sensor during the power-on sequence. 	<ol style="list-style-type: none"> 1. Remove the media from the paper path. 2. If the problem persists, perform the Paper Path Test on page 415. 3. If any delivery rollers are damaged, replace them. 4. If the problem persists, perform the sensor test. Replace any sensor that is damaged or the sensor PCA board. 5. If the problem persists, perform the motor test to check the solenoids and motors. Replace any motor or solenoid that is damaged. 6. If the problem persists and all sensors, motors, delivery rollers, and the solenoid are working properly, replace the 7-bin Tabletop Mailbox Controller PCA. See "7-bin Tabletop Mailbox Controller PCA" on page 269 for instructions.

Table 7-6. Numerical Printer Messages (continued)

Message	Event Log Category/Message	Description	Recommended Action
13.22 PAPER JAM IN OUTPUT DEVICE	13.22 01 13.22 02	Flipper Entry/Left output bin jam in the Multibin Mailbox.	<ol style="list-style-type: none">1. Open the Flipper Jam Access Door, and remove the media.2. Make sure that the sensor flag moves freely.3. Make sure that the flipper shaft is not out of place.4. If the problem persists, replace the Flipper Assembly. See "Flipper Assembly" on page 227 for instructions.5. If the problem persists, replace the Mailbox Controller PCA. See the <i>HP LaserJet 8000, 8000 N, 8000 DN, and HP Mopier 240 Printers Service Manual Supplement for Paper-handling Accessories</i> for instructions.

Table 7-6. Numerical Printer Messages (continued)

Message	Event Log Category/ Message	Description	Recommended Action
13.22 PAPER JAM IN OUTPUT DEVICE	13.22 03 13.22 04 13.22 05	Belt jam or Head Exit 1 / Exit 2 sensors timeout in the Multibin Mailbox.	<ol style="list-style-type: none"> 1. Remove the media at the double-belt system and/or Delivery Head Assembly. 2. Make sure that the double belt (both belts) moves freely. 3. Make sure that both Exit 1 and 2 sensor flags on the Delivery Head Assembly move freely. 4. Ensure the parallel position of the double belt system. 5. Make sure that the Metal Tape is in place and in good condition. 6. Check the fingers. They must be over the ejector rollers on the Delivery Head Assembly. 7. Check the Delivery Head Assembly reset cycle. If it does not work properly, replace the flat ribbon cable that connects to the Delivery Head Assembly. If the problem persists, replace the Delivery Head Assembly. 8. Check the Transport Belt reset cycle. If it does not work properly, replace the Transport Belt. If the problem persists, replace the Transport Belt Motor. 9. If the problem persists, replace the Multibin Mailbox Controller PCA. See the <i>HP LaserJet 8000, 8000 N, 8000 DN, and HP Mopier 240 Printers Service Manual Supplement for Paper-handling Accessories</i> for instructions.

Table 7-6. Numerical Printer Messages (continued)

Message	Event Log Category/Message	Description	Recommended Action
13.22 PAPER JAM IN OUTPUT DEVICE	13.22 06	Elevator jam in the Multibin Mailbox.	<ol style="list-style-type: none"> 1. Make sure that the blind cover and scan bar are installed properly 2. Check for paper jammed in the Delivery Head Assembly. 3. Make sure the Delivery Head Assembly moves freely. 4. Make sure that all paper bins are seated correctly. 5. Make sure that the paper bins, blind cover, and scan bar are not broken. 6. If the problem persists, replace the Delivery Head Assembly. 7. If the problem persists, replace the Delivery Head motor. 8. If the problem persists, replace the Mailbox Controller PCA. See the <i>HP LaserJet 8000, 8000 N, 8000 DN, and HP Mopier 240 Printers Service Manual Supplement for Paper-handling Accessories</i> for instructions.
13.22 PAPER JAM IN OUTPUT DEVICE	13.22 0A	Communication problem with the Multibin Mailbox, wrong page request.	<ol style="list-style-type: none"> 1. Turn the printer off, and then turn the printer on. 2. If the problem persists, replace the Multibin Mailbox Controller PCA. See the <i>HP LaserJet 8000, 8000 N, 8000 DN, and HP Mopier 240 Printers Service Manual Supplement for Paper-handling Accessories</i> for instructions.

Table 7-6. Numerical Printer Messages (continued)

Message	Event Log Category/ Message	Description	Recommended Action
13.33 PAPER JAM IN OUTPUT DEVICE	13.33 0A	A staple is jammed in the stapler.	Clear the jammed staple.
13.33 PAPER JAM IN OUTPUT DEVICE	13.33 0B 13.33 0C 13.33 0D	A rack jam, slider jam, or retainer jam occurred in the stapler.	1. Remove the media, and perform a device reset cycle. 2. If the problem persists, replace the Stapler Controller PCA. See “Stapler Controller PCA” on page 252 for instructions. Replace the Stapler. See “Stapler Assembly” on page 249 for instructions.
20 INSUFFICIENT MEMORY alternates with PRESS GO TO CONTINUE	Error	The printer received more data than can fit in its available memory. You might have tried to transfer too many macros, soft fonts, or complex graphics.	1. Press Go to print the transferred data (some data might be lost). 2. Simplify the print job, or install additional memory. See “Memory and Personality Upgrade” on page 147 for instructions.
21 PAGE TOO COMPLEX alternates with PRESS GO TO CONTINUE	Error	The data (dense text, rules, raster or vector graphics) sent to the printer was too complex.	1. Press Go to print the transferred data. (Some data might be lost.) 2. To print the job without losing data, from the Configuration Menu in the printer control panel, set PAGE PROTECT=ON, print the job, and then return to PAGE PROTECT=AUTO. Do not leave PAGE PROTECT=ON; it might degrade performance. If this message appears often, simplify the print job.

Table 7-6. Numerical Printer Messages (continued)

Message	Event Log Category/Message	Description	Recommended Action
22 EIO × BUFFER OVERFLOW alternates with PRESS GO TO CONTINUE	Error	Too much data was sent to the EIO card in the specified slot (×). An improper communications protocol may be in use.	<ol style="list-style-type: none">1. Press Go to clear the message. (Data will be lost.)2. Check the host configuration.
22 PARALLEL I/O BUFFER OVERFLOW alternates with PRESS GO TO CONTINUE	Error	Too much data was sent to the parallel port. This error can occur if the driver you are using is not IEEE-1284 compliant. For best results, use an HP driver that came with the printer.	<ol style="list-style-type: none">1. Check for a loose cable connection and be sure to use a high-quality cable. (Some non-HP parallel cables might be missing pin connections or might otherwise not conform to the IEEE-1284 specification.) This error can occur if the driver you are using is not IEEE-1284 compliant. For best results, use an HP driver that came with the printer.2. Press Go to clear the error message. (Data will be lost.)
22 SERIAL I/O BUFFER OVERFLOW alternates with PRESS GO TO CONTINUE	Error	Too much data was sent to the serial port.	<ol style="list-style-type: none">1. Make sure that the correct serial pacing option is selected from the I/O Menu in the printer's control panel.2. Print a Menu Map, and verify that the serial pacing item (from the I/O Menu in the printer's control panel) matches the setting on the computer.3. Press Go to clear the error message. (Data will be lost.)

Table 7-6. Numerical Printer Messages (continued)

Message	Event Log Category/ Message	Description	Recommended Action
40 BAD SERIAL TRANSMISSION alternates with PRESS GO TO CONTINUE	Error	<p>The printer encountered an error while transferring data from the computer. The error might have occurred for several reasons:</p> <ul style="list-style-type: none"> • The computer was powered on or off while the printer was online. • The printer's serial configuration was not the same as the computer's. 	<ol style="list-style-type: none"> 1. Verify the cable connections. Make sure that the printer's serial configuration is set the same as the computer from the I/O Menu in the printer's control panel. 2. The serial baud rate setting can be accessed from the I/O Menu in the printer's control panel. 3. Press Go to clear the error message and continue the printing. 4. Turn the printer off. 5. Reseat the EIO card, and turn the printer on.
40 EIO x BAD TRANSMISSION alternates with PRESS GO TO CONTINUE	Error	<p>The connection has been broken between the printer and the EIO card in the specified slot.</p>	<ol style="list-style-type: none"> 1. Turn the printer off, and reseat the card. 2. Press Go to clear the error message and continue printing.
41.3 UNEXPECTED PAPER SIZE	Error	<p>The paper size you are trying to print is not the same as the control panel setting for Tray 1.</p>	<ol style="list-style-type: none"> 1. Make sure that the control panel setting for Tray 1 or the Envelope Feeder is correctly adjusted for size. (The printer will continue trying to print the job until the size settings are correct.) 2. Press Go. The page containing the error will automatically be reprinted. (Or, you might want to press CANCEL JOB to clear the job from the printer's memory.)

Table 7-6. Numerical Printer Messages (continued)

Message	Event Log Category/Message	Description	Recommended Action
41.x PRINTER ERROR alternates with PRESS GO TO CONTINUE	Error	A temporary printing error occurred. X Description 1 Unknown misprint error. 2 Beam detect misprint error. 3 See error 41.3 above. 4 No VSYNC error. 5 Media feed error. 9 Noise VSREQ error.	1. Press Go . The page containing the error will automatically be reprinted. If this message persists: 1. Reseat the connections to the Laser/Scanner and the Engine Controller Board. 2. Replace the Laser/Scanner. See “Laser/Scanner Assembly” on page 189 for instructions. 3. Replace the Engine Controller Board.
50.x FUSER ERROR	Critical Error	A fuser error has occurred. X Description 1 Low Fuser temperature. 2 Fuser warm up service. 3 High Fuser temperature. 4 Faulty Fuser. 5 Inconsistent Fuser.	1. Turn the printer off for at least 20 minutes, and then turn the printer on. If the error continues: 1. Make sure that the Fusing Assembly is installed correctly and is fully seated into its connectors (no bent pins or pins outside their receptacles). 2. Reseat or replace the fuser cable assembly. 3. Replace the DC Controller.

Table 7-6. Numerical Printer Messages (continued)

Message	Event Log Category/Message	Description	Recommended Action
51.x PRINTER ERROR	Error	A temporary printing error occurred. X Description 1 Beam detect error. 2 Laser error.	<ol style="list-style-type: none"> 1. Press Go. The page containing the error will automatically be reprinted. 2. Turn the printer off, and then turn the printer on. 3. Reseat the cables. See the wiring diagrams at the back of this manual. 4. Replace the Laser/Scanner. See “Laser/Scanner Assembly” on page 189 for instructions.
52.x PRINTER ERROR	Error	A temporary printing error occurred. X Description 0 Laser/scanner error. 1 Laser/scanner startup error. 2 Laser/scanner rotation error.	<ol style="list-style-type: none"> 1. Press Go. The page containing the error will automatically be reprinted. 2. Turn the printer off, and then turn the printer on. 3. Reseat the cables. See the wiring diagrams at the back of this manual. 4. Replace the Laser/Scanner. See “Laser/Scanner Assembly” on page 189 for instructions.
66.XX.YY FINISHER FAILURE alternates with CHECK CABLES AND CYCLE POWER	Error	A finisher device in an external paper handling output device failed.	<ol style="list-style-type: none"> 1. Check the cable connections. 2. Reseat or replace the device.

Table 7-6. Numerical Printer Messages (continued)

Message	Event Log Category/Message	Description	Recommended Action
66.00.xx INPUT DEVICE FAILURE alternates with CHECK CABLES AND CYCLE POWER	Error	An error occurred in an external paper handling device.	Turn the printer off, and then turn the printer on.
66.00.xx SERVICE ERROR	66.00.xx	A communication error occurred in the paper-handling controller.	<ol style="list-style-type: none"> 1. Turn the printer off, and then turn the printer on. 2. If the problem persists, replace the PCA controller board for the device. 3. If the problem persists, replace the Formatter PCA.
66.00.15 SERVICE ERROR	66.00.15	The paper-handling controller had a bad C-link (communication). This error is due to a power failure.	<ol style="list-style-type: none"> 1. Turn the printer off, and then turn the printer on. 2. If the problem persists, check the C-link and power cables. 3. If the problem persists, check the device power connector and power supply (internal or external). Replace if damaged. 4. If the problem persists, replace the PCA Controller board for the device. 5. If the problem persists, replace the Formatter PCA.
66.00.19 66.00.20 66.00.21 66.00.22 66.00.23 66.00.24 SERVICE ERROR	66.00.19 66.00.20 66.00.21 66.00.22 66.00.23 66.00.24	<p>Page not expected.</p> <p>Error 66.00.23 is due to a bad C-link connection or a damaged C-link cable.</p>	<ol style="list-style-type: none"> 1. Turn the printer off, and then turn the printer on. 2. If the problem persists, replace the PCA Controller board for the device. 3. If the problem persists, replace the Formatter PCA.

Table 7-6. Numerical Printer Messages (continued)

Message	Event Log Category/Message	Description	Recommended Action
66.00.26	66.00.26	A page count error occurred.	<ol style="list-style-type: none"> 1. Turn the printer off, and then turn the printer on. 2. If the problem persists, replace the PCA Controller board for the device. 3. If the problem persists, replace the Formatter PCA.
66.00.27	66.00.27		
66.00.28	66.00.28		
SERVICE ERROR			
66.00.31	66.00.31	Device or engine X is not supported. The configuration for X is invalid.	Verify the supported devices.
66.00.32	66.00.32		
66.00.33	66.00.33		
66.00.34	66.00.34		
66.00.35	66.00.35		
66.00.36	66.00.36		
66.00.37	66.00.37		
66.00.38	66.00.38		
66.00.39	66.00.39		
66.00.40	66.00.40		
66.00.41	66.00.41		
66.00.42	66.00.42		
66.00.43	66.00.43		
66.00.44	66.00.44		
66.00.45	66.00.45		
SERVICE ERROR			

Table 7-6. Numerical Printer Messages (continued)

Message	Event Log Category/Message	Description	Recommended Action
66.11.01 66.11.02 66.11.03 INPUT DEVICE FAILURE	66.11 01 66.11 02 66.11 03	A lifting and/or feed motor malfunction occurred in the 2000-sheet Input Tray.	<ol style="list-style-type: none"> 1. Make sure that the lifting plate lifts up freely by hand. 2. Make sure that the paper size plates are installed correctly and are not bent. 3. Make sure that the Pickup roller is installed properly. 4. Check the Pickup Assembly, and replace if necessary. See the <i>HP LaserJet 8000, 8000 N, 8000 DN, and HP Mopier 240 Printers Service Manual Supplement for Paper-handling Accessories</i> for instructions. 5. Replace Tray 4. See "2000-sheet or 2 x 500-sheet Input Tray" on page 151 for instructions.
66.12.32 OUTPUT DEVICE FAILURE	66.12.32	A malfunction occurred in the solenoid for the 7-bin Tabletop Mailbox.	<ol style="list-style-type: none"> 1. Perform a motor test. 2. Replace the solenoid if it is damaged. 3. If the problem persists, replace the 7-bin Tabletop Mailbox Controller PCA. See "7-bin Tabletop Mailbox Controller PCA" on page 269 for instructions.
66.22.32 OUTPUT DEVICE FAILURE	66.22.32	A malfunction occurred in the solenoid for the 7-bin Tabletop Mailbox.	<ol style="list-style-type: none"> 1. Perform a motor test. 2. Replace the solenoid if it is damaged. 3. If the problem persists, replace the 7-bin Tabletop Mailbox Controller PCA. See "7-bin Tabletop Mailbox Controller PCA" on page 269 for instructions.

Table 7-6. Numerical Printer Messages (continued)

Message	Event Log Category/ Message	Description	Recommended Action
66.22.08 OUTPUT DEVICE FAILURE	66.22.08	A malfunction occurred in the Flipper motor in the Multibin Mailbox.	1. Check for stuck paper in the Flipper Assembly area. 2. If the problem persists, replace the Flipper Assembly. 3. If the problem persists, replace the Multibin Mailbox Controller PCA. See the <i>HP LaserJet 8000, 8000 N, 8000 DN, and HP Mopier 240 Printers Service Manual Supplement for Paper-handling Accessories</i> for instructions.
66.22.09 OUTPUT DEVICE FAILURE	66.22.09	An external memory error occurred in the Multibin Mailbox.	Replace the Multibin Mailbox Controller PCA. See the <i>HP LaserJet 8000, 8000 N, 8000 DN, and HP Mopier 240 Printers Service Manual Supplement for Paper-handling Accessories</i> for instructions.
66.22.xx OUTPUT DEVICE FAILURE	66.22.xx	The Multibin Mailbox C-link is not responding.	Check the C-link connection and cables.
66.22.xx OUTPUT DEVICE FAILURE	66.22.xx	The power line had a power surge.	Replace the C-link cables.

Image Quality

When you are working with customers, obtain a print sample before you begin troubleshooting their printer. Ask the customer to explain the quality they expect from the printer. The print sample will also help clarify the customer's explanation.

Table 7-7. Image Quality

Problem	Action
1. Do you have a print sample?	Obtain a print sample from the customer.
2. Does the problem repeat on the page?	Use the Repetitive Defect Ruler in figure 7-10 on page 408.
3. Is the toner cartridge full and is it manufactured by HP?	Check the toner cartridge using the check list on page 395.
4. Is the printer clean?	Perform the cleaning procedure described in "Cleaning the Printer and Accessories" on page 88.
5. Is the customer using print media that meets all HP paper specification standards?	For more information about HP's paper specification standards, see "Paper Capacities and Sizes" on page 4 and the <i>HP LaserJet Family Paper Specification Guide</i> .
6. Is the print sample similar to those in the "Image Quality Tables" on page 396?	Compare and perform the actions recommended in "Image Quality Tables" on page 396.
7. Is the problem on the drum or transfer roller?	Perform the steps in "Half Self Test Functional Check" on page 409 to determine where the defect is. If the defect is on the drum, replace the toner cartridge. If it is not on the drum, replace the transfer roller.

Check the Toner Cartridge

Image formation defects are often the result of toner cartridge problems. If there is any doubt, always replace the toner cartridge before troubleshooting image defects.

Use the following check list to make sure that the toner cartridge is still operable.

- Make sure that the toner cartridge has toner.
Full toner cartridge weight = 3000 grams (106 oz)
Empty weight = 2200 grams (80.5 oz)
- Check the expiration date of the toner cartridge (stamped on the cartridge box).
- Check the toner cartridge to see if it has been disassembled or refilled.
- Make sure that the toner cartridge is seated properly in the printer cavity.
- Inspect the cartridge for toner leaking through worn seals. (If the drum has been manually rotated it may have caused internal damage and toner spills may result.)

Note

Toner cartridges are rated for 15,000 images at 5% coverage. It is possible to wear out the gears and the cartridge seals before **TONER LOW** is displayed if the 15,000 image expectancy is exceeded.

- Check the surface of the photosensitive drum in the toner cartridge to see if it has been damaged or scratched. Touching the drum will contaminate the photosensitive surface and may cause spotting and defects during printing.
- White areas on the page may indicate that the drum has been exposed to light for too long. If white areas appear, stop the printer and wait a few minutes. This should eliminate most defective images. If not, the toner cartridge may be placed in a dark environment for several days, which may restore some life to the drum.

Image Quality Tables

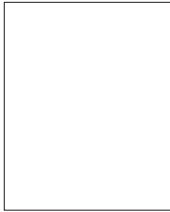

Table 7-8. Blank (White) Page

Possible Cause

Recommended Action

OCCASIONAL BLANK PAGES:

1. Software Configuration.

Make sure that the application software is not sending incorrect page length requests, or extra page eject commands.

2. Network Configuration. Some sharing devices on networks may generate a blank page as a separator.

Check with the network administrator.

3. Multiple Feeds. The printer may be feeding two or more pages at once because the paper is difficult to separate.

Remove the paper from the tray and fan the paper edges to separate the pages (see the *HP LaserJet Printer Family Paper Specifications Guide*).

ALL PAGES BLANK:

1. Sealing tape left in toner cartridge.

Remove the sealing tape.



Table 7-9. Black Pages

Possible Cause

Recommended Action

1. Defective toner cartridge.

Replace the toner cartridge.

2. Light is leaking into the printer.

Make sure that all covers are in place.

3. High voltage contact springs are dirty or defective. The high voltage contacts are mounted on the High Voltage Power Supply PCA and protrude into the toner cartridge cavity.

Inspect and clean the high voltage contacts. If damaged, replace the High Voltage Power Supply PCA. See “Power Supply, High Voltage (HVPS)” on page 205 for instructions.

Table 7-9. Black Pages (continued)

Possible Cause	Recommended Action
4. High voltage power supply circuit is defective (not supplying the correct negative voltage).	Replace the High Voltage Power Supply PCA. See "Power Supply, High Voltage (HVPS)" on page 205 for instructions.
5. DC Controller PCA is defective. If the DC Controller turns on the laser beam continuously, the entire surface of the Photosensitive drum is neutralized causing a completely black page.	Replace the DC Controller PCA. See "PCA, DC Controller" on page 197 for instructions.
6. Laser/Scanner Assembly is faulty (turning laser on continuously).	Replace the Laser/Scanner Assembly. See "Laser/Scanner Assembly" on page 189 for instructions.
7. Connectors between the Laser/Scanner unit and DC Controller are not seated properly or are defective.	Inspect and reseal the connectors. Replace cables as necessary.



Table 7-10. Fading Print

Possible Cause	Recommended Action
1. Toner supply is low.	Shake the cartridge gently to redistribute the toner, or replace the cartridge.
2. Print Density is set incorrectly.	Change to a darker setting and retry printing.
3. EconoMode is on. EconoMode saves toner by reducing the dot density. This may appear to be a print quality problem in some cases.	Turn EconoMode off. Verify that EconoMode is not being enabled by either the printer driver or the job application.
4. Paper does not meet specifications. The moisture content, conductivity, or surface finish may not work correctly with the electrophotographic process.	Try a different paper lot (see <i>HP LaserJet Printer Family Paper Specifications Guide</i>).



Table 7-10. Fading Print (continued)

Possible Cause	Recommended Action
5. Transfer Roller is defective or incorrectly installed. If the Transfer Roller loses conductivity, it cannot effectively pull toner from the drum to the paper.	Inspect the Transfer Roller for proper installation and contact. If the Transfer Roller is damaged, replace it. See "Transfer Roller Assembly" on page 219 for instructions.
6. Laser/Scanner door is not opening properly.	1. Remove and reseal the toner cartridge. 2. Check the Laser/Scanner shutter door for proper operation. If defective, replace the Laser/Scanner Assembly. See "Laser/Scanner Assembly" on page 189 for instructions.
7. High voltage contact springs are dirty or defective. The high voltage contacts are mounted on the High Voltage Power Supply PCA and protrude into the toner cartridge cavity.	Check the contacts for functionality. If dirty, clean using alcohol; if damaged, replace the High Voltage Power Supply PCA. See "Power Supply, High Voltage (HVPS)" on page 205 for instructions.
8. High Voltage Power Supply PCA is defective.	Replace the High Voltage Power Supply PCA. See "Power Supply, High Voltage (HVPS)" on page 205 for instructions.
9. DC Controller PCA is defective. The DC Controller supplies the proper voltage to the High Voltage Power Supply PCA.	Replace the DC Controller PCA. See "PCA, DC Controller" on page 197 for instructions.

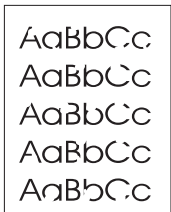

Table 7-11. Dropout

Possible Cause	Recommended Action
1. Single sheet of paper is defective.	Try reprinting the job.
2. Paper does not meet specifications. The moisture content, conductivity, or surface finish may not work correctly with the electrophotographic process.	Try a different paper lot (see <i>HP LaserJet Printer Family Paper Specifications Guide</i>).
3. DC Controller is defective (low primary voltage).	Replace the DC Controller. See "PCA, DC Controller" on page 197 for instructions.



Table 7-11. Dropout (continued)

Possible Cause	Recommended Action
4. High Voltage Power Supply PCA is defective.	Replace the High Voltage Power Supply PCA. See "Power Supply, High Voltage (HVPS)" on page 205 for instructions.
5. Transfer Roller is defective.	Replace the Transfer Roller. See "Transfer Roller Assembly" on page 219 for instructions.

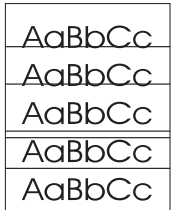

Table 7-12. Black Lines (parallel or perpendicular to path)

Possible Cause	Recommended Action
1. Toner cartridge is not seated properly.	Remove the cartridge and reinsert it.
2. Toner cartridge is damaged.	Inspect the toner cartridge for a scratched or streaked photosensitive drum. Clean the printer (see "Cleaning the Printer and Accessories" on page 88), and replace the cartridge.
3. Fusing Assembly is contaminated or damaged.	Inspect the Fusing Assembly for toner build-up or scratches on the fuser rollers. Try cleaning with alcohol. Replace the Fusing Assembly if damaged. See "Fusing Assembly" on page 187 for instructions.
4. Static Eliminator Strip teeth are contaminated or defective.	Clean using compressed air.
5. Repetitive defect. If the lines are repeated at a consistent interval down the page, this is a repetitive defect.	See the Repetitive Image Defect Ruler (figure 7-10 on page 408).



Table 7-13. Toner Smear

Possible Cause

Recommended Action

- | | |
|---|---|
| <p>1. Paper does not meet specifications. The moisture content, conductivity, or surface finish of the media being printed may not work correctly with the electrophotographic process.</p> | <p>Try a different paper lot or other media (see <i>HP LaserJet Printer Family Paper Specifications Guide</i>).</p> |
| <p>2. Fusing Rollers are dirty. Toner build-up can cause the print on a page to smear.</p> | <p>Remove and inspect the Fusing Assembly for excessive toner build-up. Clean using alcohol.</p> |
| <p>3. The Static Eliminator Strip is dirty or is not grounded, allowing a static charge to remain on the page.</p> | <p>Clean the Anti-Static Brush using compressed air.</p> |
| <p>4. Fusing Assembly is defective. The print will smear if the Fusing Assembly is not heated sufficiently to bond the toner image to the paper.</p> | <p>Replace the Fusing Assembly. See “Fusing Assembly” on page 187 for instructions.</p> |
| <p>5. DC Controller is defective. The DC Controller regulates fusing roller temperature.</p> | <p>If a new Fusing Assembly does not resolve the problem, replace the DC Controller PCA. See “PCA, DC Controller” on page 197 for instructions.</p> |
-



Table 7-14. Background Scatter

Possible Cause

Recommended Action

Random Background Scatter

- | | |
|---|---|
| <p>1. Paper does not meet specifications. The moisture content, conductivity or surface finish may not work correctly with the electrophotographic process.</p> | <p>Try a different media or paper lot (see <i>HP LaserJet Printer Family Paper Specifications Guide</i>).</p> |
| <p>2. Inside of printer is dirty (toner may have leaked out of the toner cartridge).</p> | <p>Clean inside of printer (see “Cleaning the Printer and Accessories” on page 88). Install a new toner cartridge if leaking.</p> |

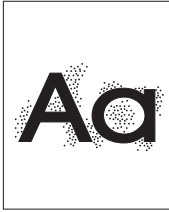

Table 7-14. Background Scatter (continued)

Possible Cause	Recommended Action
3. Printing on envelope seams. Printing on an envelope seam can cause a background scatter problem.	Move the text to an area without seams. If not printing on seams, try a higher print density setting (see item 6, below).
4. Toner cartridge is defective.	Install a new toner cartridge.
5. Transfer Roller is dirty or worn. A worn Transfer Roller can cause background scatter due to improper bias voltages.	Clean the Transfer Roller using a dry, lint-free cloth. DO NOT touch the Transfer Roller with your fingers. If the problem persists, replace the Transfer Roller Assembly. See "Transfer Roller Assembly" on page 219 for instructions.
6. Print Density is set too low causing background scatter, particularly with envelopes and heavier papers.	Adjust the print density to a higher setting.

Background Scatter at Leading Edge Only (Leading Edge Halo)

1. Toner buildup in the Fuser Inlet Guide.	Clean Fuser Inlet Guide. See "Cleaning the Printer and Accessories" on page 88 for instructions.
--	--

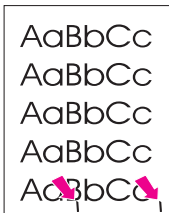

Table 7-15. Repetitive Defects

Possible Cause	Recommended Action
1. Toner cartridge is damaged. If the defect repeats at any of the following intervals and in the direction of paper movement, it is associated with a component inside the toner cartridge. See figure 7-10 on page 408.	Inspect the drum for scratches or damage. Replace the toner cartridge. Use the Repetitive Defect Ruler, figure 7-10 on page 408.
2. Transfer Roller has toner on it. If defects occur on the back of the page at intervals of 61mm (2 3/8 inches), the Transfer Roller may be dirty. This problem sometimes corrects itself after a few pages.	Clean the Transfer Roller using a dry, lint-free cloth. DO NOT touch the Transfer Roller with your fingers. If the problem persists, replace the Transfer Roller Assembly. See "Transfer Roller Assembly" on page 219 for instructions.

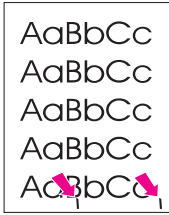

Table 7-15. Repetitive Defects (continued)

Possible Cause	Recommended Action
3. Rollers are dirty. Any dirty roller in the paper path may result in a repetitive print defect.	Examine and clean the rollers in the paper path. See "Cleaning the Printer and Accessories" on page 88.
4. Fusing Assembly is dirty or defective.	Clean the Fusing Assembly using alcohol. If the problem persists, replace the Fusing Assembly. See "Fusing Assembly" on page 187 for instructions.
5. Gears are worn, causing slippage or jumping.	Inspect the gears driving the toner cartridge and the Fuser. Replace the Main Drive Assembly if necessary. See "Main Gear Assembly" on page 191 for instructions.
6. Paper does not meet specifications. The surface of the paper may be too coarse, causing repeated marks.	Try a different media or paper lot (see <i>HP LaserJet Printer Family Paper Specifications Guide</i>).



Table 7-16. Line at Edge of Paper

Possible Cause	Recommended Action
Toner cartridge is defective. The photosensitive drum is wearing out. The line will grow wider, with cross-hatching. Shaking the cartridge does not relieve the problem.	Replace the toner cartridge.

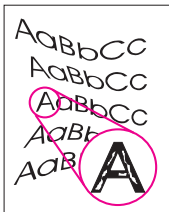

Table 7-17. Misshapen Characters, Voids

Possible Cause	Recommended Action
1. Paper surface too rough. Toner migrates to low spots, leaving higher areas void.	Turn EconoMode off. Use paper with correct finish (smoothness) (see <i>HP LaserJet Printer Family Paper Specifications Guide</i>).

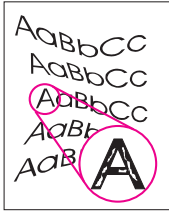

Table 7-17. Misshapen Characters, Voids (continued)

Possible Cause	Recommended Action
<p>2. Printing on wrong side of paper. The label on the ream of paper indicates which side to print on. The different surface properties of some papers may cause problems if loaded wrong side up.</p>	<p>Turn EconoMode off. Check for the arrow on the paper wrapper. Be sure paper is loaded with the arrow pointing up in Tray 1 or down in Trays 2, 3, 4, and 5.</p>
<p>3. Paper surface is too smooth for proper toner adhesion.</p>	<p>Turn EconoMode off. Use paper with correct finish (smoothness) (see <i>HP LaserJet Printer Family Paper Specifications Guide</i>).</p>
<p>4. Transparencies are bad. Transparencies can have this problem because they are not designed for proper toner adhesion.</p>	<p>Turn EconoMode off. Use Hewlett-Packard approved transparencies (see <i>HP LaserJet Printer Family Paper Specifications Guide</i>).</p>
<p>5. Transfer Roller is bad. If the Transfer Roller has finger oils on its surface, is dirty, or is worn-out, this problem can result.</p>	<p>Turn EconoMode off. Clean the Transfer Roller using a dry, lint-free cloth. DO NOT touch the Transfer Roller with your fingers. If the problem persists, replace the Transfer Roller Assembly. See "Transfer Roller Assembly" on page 219 for instructions.</p>
<p>6. Laser/Scanner Assembly is bad.</p>	<p>Replace the Laser/Scanner Assembly. See "Laser/Scanner Assembly" on page 189 for instructions.</p>



Table 7-18. Faulty Registration

Possible Cause	Recommended Action
<p>1. Paper tray is overloaded. If the tray is overloaded, the Pickup Rollers may not pick correctly.</p>	<p>Reload proper amount of paper squarely in the tray. Review paper loading with the customer.</p>
<p>2. Paper guide on the paper tray is incorrectly adjusted. If the guide is pushing too tightly against the paper, it may be delayed in being pulled into the printer. If the guide is too loose, it may cause image skewing.</p>	<p>Make sure that the paper guide is adjusted for the correct paper size and is locked into position.</p>



Table 7-18. Faulty Registration (continued)

Possible Cause	Recommended Action
<p>3. Paper does not meet specifications. The surface of the paper may be too smooth for the Pickup and Feed Rollers to correctly feed paper into the printer.</p>	<p>Try a different paper lot (see <i>HP LaserJet Printer Family Paper Specifications Guide</i>).</p>
<p>4. Drive gears are worn or broken. If any gear within the drive train or paper path becomes excessively worn or dirty, erratic paper movement can result.</p>	<p>Replace the defective gear or Main Drive assembly. See "Main Gear Assembly" on page 191 for instructions.</p>
<p>5. Worn Pickup or Registration Rollers. Paper is not being picked up consistently.</p>	<p>Inspect all paper path rollers, looking for wear, cracks, or glazing. Replace the worn rollers.</p>

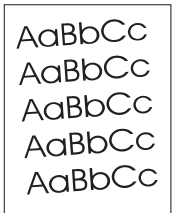

Table 7-19. Image Skew

Possible Cause	Recommended Action
<p>1. Paper is loaded incorrectly. If the paper is not installed flush into the paper tray, a skewing problem will result.</p>	<p>Remove paper from the tray, and install paper correctly. Position the paper guide correctly for the paper size being used.</p>
<p>2. Paper lot is bad. Paper that is manufactured poorly or inconsistently or that has too smooth or too rough a surface texture can cause an image skew problem.</p>	<p>Try a different paper lot (see <i>HP LaserJet Printer Family Paper Specifications Guide</i>).</p>
<p>3. Pickup and/or Registration Rollers are worn. Paper is not being picked up consistently.</p>	<p>Inspect all paper path rollers, looking for wear, cracks, or glazing. Replace the worn rollers.</p>

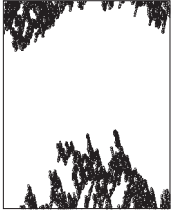

Table 7-20. Bubble Print

Possible Cause

Recommended Action

1. Photosensitive drum inside toner cartridge is not grounded.

1. Check for proper mounting of the High Voltage Power Supply (HVPS) and the HVPS ground contacts on the toner cartridge.

2. Check for proper seating of toner cartridge.

3. Replace the toner cartridge.

2. High Voltage Power Supply is defective.

Replace the High Voltage Power Supply. See “Power Supply, High Voltage (HVPS)” on page 205 for instructions.

3. Toner cartridge is leaking.

Replace the toner cartridge.

4. Paper does not meet specifications. The moisture content, conductivity, or surface finish may not work correctly with the electrophotographic process.

Try a different paper lot (see *HP LaserJet Printer Family Paper Specifications Guide*).

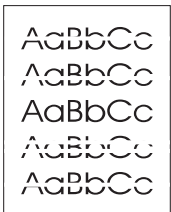

Table 7-21. White Stripes Parallel to Path

Possible Cause

Recommended Action

1. Toner cartridge is nearly empty. This can cause uneven toner distribution.

Remove the toner cartridge, and shake it gently. The cartridge will soon require replacement.

2. Toner cartridge has been exposed to too much light.

Store the toner cartridge in a darkened environment for several days. This may restore the photosensitive potential.

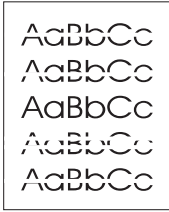

Table 7-21. White Stripes Parallel to Path (continued)

Possible Cause	Recommended Action
3. Foreign objects in beam path. Any foreign objects will block the light from developing an image on the Photosensitive drum.	Remove the toner cartridge, and check for damage. Replace the toner cartridge if it is damaged. Remove the printer cover, and inspect the path from the Laser/Scanner to the toner cartridge drum, looking for foreign objects in the beam path.

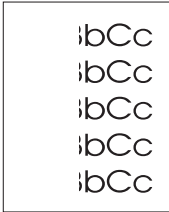

Table 7-22. Partial Blank Page

Possible Cause	Recommended Action
1. Page is too complex. The printer cannot create the image fast enough to keep pace with the print engine.	Set Page Protect to on or auto.
2. Not enough memory. The page is too complex for standard printer memory.	Add printer memory. See “Memory and Personality Upgrade” on page 147 for instructions. As an alternative, simplify the print job.
3. Printing on legal-size paper from Tray 4 when software is specifying letter size (this will also cause paper jams).	Review software selection. Make sure that printing is on selected size.



Table 7-23. Compressed Print

Possible Cause	Recommended Action
1. Toner cartridge bushings are too tight. This may occur on refilled toner cartridges.	Replace the toner cartridge.
2. Gear is broken or worn.	Inspect and replace the worn gear or assembly.

A_c 3bCc
A_c 3bCc
A_c 3bCc
A_c 3bCc
A_c 3bCc

Table 7-24. Blank Portion in the Middle of the Page (Tray 4 Input only)

Possible Cause	Recommended Action
1. Bad clutch in vertical transfer door.	Replace the Tray 4 vertical transfer door. See the <i>HP LaserJet 8000, 8000 N, 8000 DN, and HP Mopier 240 Printers Service Manual Supplement for Paper-handling Accessories</i> for instructions.
2. Bad clutch in paper pickup assembly.	Replace Tray 4 paper pickup assembly. See the <i>HP LaserJet 8000, 8000 N, 8000 DN, and HP Mopier 240 Printers Service Manual Supplement for Paper-handling Accessories</i> for instructions.

Repetitive Defect Ruler

Repetitive print defects are usually associated with a specific roller within the printer or the toner cartridge. Use figure 7-10 to isolate the cause of repetitive print defects. Align the first occurrence of the defect with the top of the “ruler” and measure to the next occurrence of the defect to determine the roller in question. When you are certain that your defect pattern matches the pattern of the ruler, replace the indicated roller.

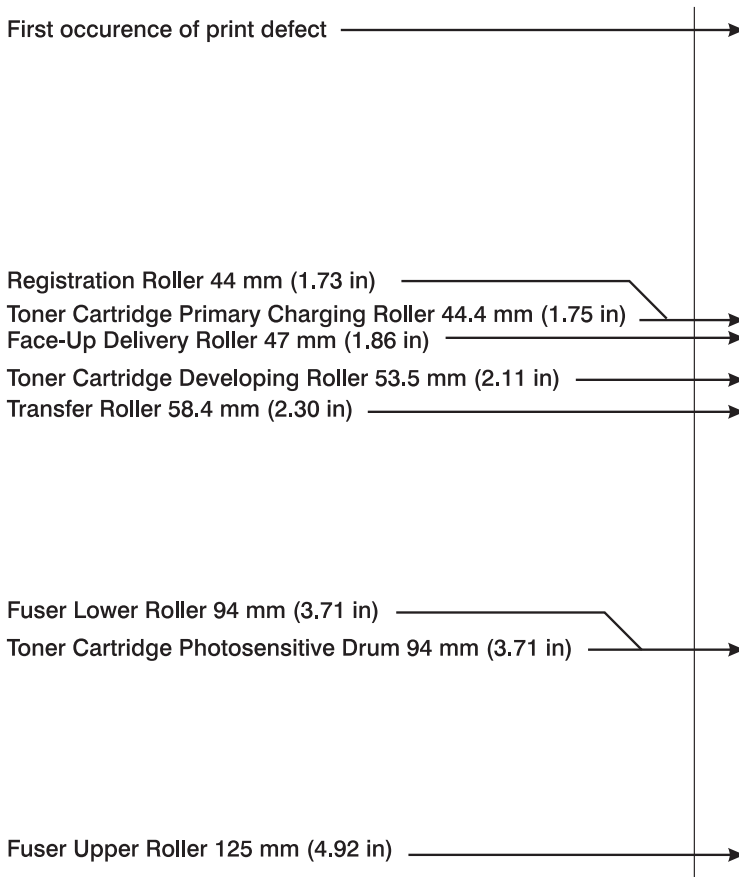

Figure 7-10 Repetitive Defect Ruler

Image System Troubleshooting

Half Self Test Functional Check

The electrophotographic process can be subdivided into the following stages:

- Cleaning (removing excess toner from drum surface)
- Conditioning (placing a uniform electrical charge on drum)
- Writing (laser strikes surface of drum to create latent image)
- Development (formation of the toner image on drum)
- Transfer (charge to transfer the image to paper)
- Fusing (heat and pressure to produce a permanent image)

See Chapter 5 for more information.

The purpose of the Half Self Test Check is to determine which process is malfunctioning. Perform the test as follows:

- 1 Print a Configuration Page. See “Configuration Page” on page 342 for instructions.
- 2 Open the top cover after the paper advances half-way through the printer (about five seconds after the Main Motor begins rotating). The leading edge of the paper should have advanced past the toner cartridge.
- 3 Remove the toner cartridge.
- 4 Open the toner cartridge's drum shield to view the drum's surface.

If a *dark and distinct toner image is present* on the drum's surface, assume that the first four functions of the electrophotographic process are functioning (cleaning, conditioning, writing, and developing—see Chapter 5), and troubleshoot the failure as a transfer or fusing problem.

If *NO image is present* on the photosensitive drum, perform the functional checks on the following pages:

Drum Rotation Functional Check

The photosensitive drum, located in the toner cartridge, must rotate for the print process to work. The photosensitive drum receives its drive from the Main Drive assembly. To verify whether the drum is rotating:

- 1 Open the top cover.
- 2 Remove the toner cartridge.
- 3 Mark the cartridge's drive gear with a felt-tipped marker. Note the position of the mark.
- 4 Install the toner cartridge, and close the top cover. The start-up sequence should rotate the drum enough to move the mark.
- 5 Open the printer, and inspect the gear that was marked in step 3. Verify that the mark moved. If the mark did not move, inspect the Main Drive assembly to make sure that it is meshing with the toner cartridge gears. If the drive gears appear functional, and the drum does not move, replace the toner cartridge.

Note

This test is especially important if refilled toner cartridges have been used.

High-Voltage Power Supply Check

The High-Voltage Power Supply PCA provides the necessary voltages for the electrophotographic processes (see figure 7-11 on page 411). A method for verifying the high-voltage system is given below:

Toner cartridge connection points

Visually inspect the four connection points on the inside right end of the toner cartridge. If they are dirty or corroded, clean the connections. Clean using only alcohol. If damaged, replace the toner cartridge.

High voltage contacts

The high voltage contact springs mount on the High Voltage Power Supply PCA and protrude through the toner cartridge cavity to contact the toner cartridge. Verify that the contacts are not dirty or corroded and that the spring action is functional. If dirty, clean using only alcohol. If damaged, replace the High Voltage Power Supply PCA (see "Power Supply, High Voltage (HVPS)" on page 205 for instructions).

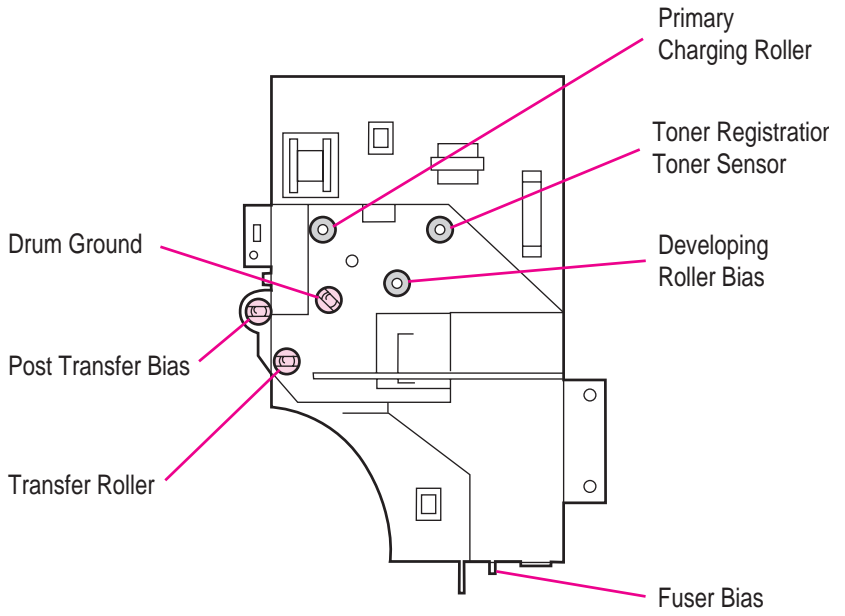

Figure 7-11 High Voltage Power Supply Contacts

Troubleshooting Checks

Paper Jams

Paper jams occur most often when:

- Paper trays are not correctly loaded. Make sure the paper is loaded with the arrow pointing up in Tray 1 and down in Trays 2, 3, 4, and 5.
- The print media does not meet the specifications listed in the *HP LaserJet Printer Family Paper Specifications Guide*.
- The media is in poor condition.
- The printer needs cleaning.

The printer monitors the timing of four sensors to determine that a paper jam has occurred: PS2, PS1, PS1403, and PS1402.

If a paper jam occurs, the printer will display a 13.× PAPER JAM message on the control panel. See table 7-6 on page 373 for detailed descriptions of the 13.× messages and the recommended actions to resolve the errors.

Figure 7-12 shows the possible locations for most of the paper jams.

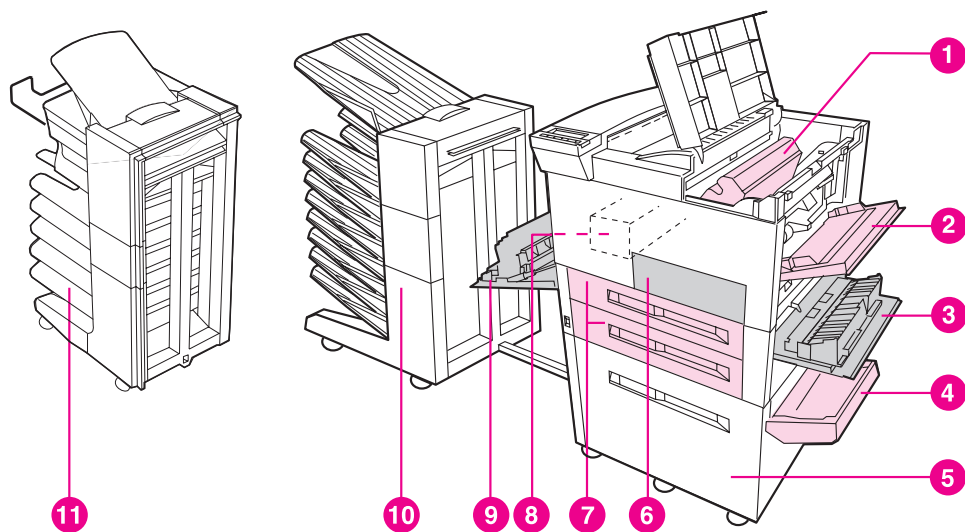

Figure 7-12 Paper Path Jam Locations

- | | | | |
|----|---|-----|---|
| 1. | Toner cartridge area | 7. | Tray 2 and Tray 3 |
| 2. | Tray 1 pickup roller and feed area | 8. | Fusing Assembly Area |
| 3. | Right door | 9. | Left door |
| 4. | Tray 4 (2000-sheet Input Tray) and Tray 5 (2 x 500-sheet Input Tray, not shown) transfer door | 10. | Multibin Mailbox 7-bin Tabletop Mailbox (not shown) |
| 5. | Tray 4 (2000-sheet Input Tray) and Tray 5 (2 x 500-sheet Input Tray, not shown) | 11. | Mailbox with Stapler |
| 6. | Front door | | |

General Paper Path Troubleshooting

Paper jams occur in the printer when paper either does not reach or clear a photosensor along the printer's paper path in a specific amount of time. If a paper jam occurs, a **13.xx PAPER JAM** message is displayed on the printer's Control Panel. The following lists general questions you should ask and topics you should explore prior to troubleshooting:

Table 7-25. General Paper Path Troubleshooting Questions

Problem	Action
What is the frequency of the paper jams (e.g. continuous, one jam per 100 pages, one jam per 1000 pages, etc.)?	Verify with the customer. Print or display the Event Log to determine paper jam history. See "Display" on page 336 and "Printer Messages" on page 351 and evaluate the Event Log.
Do paper jams only occur when the paper is fed from a particular paper input source (e.g., Tray 1, Tray 2, Tray 3, Tray 4, Tray 5, or Envelope Feeder)?	See "Troubleshooting Checks" on page 412 and use the Paper Path Test to isolate the problem.
Do jams only occur when paper is output to a specific output bin (e.g., standard output bin, left output bin, mailbox bin, duplex operation, stapler)?	Use "Paper Path Test" on page 415 to isolate the problem.
Do paper jams occur with a specific type of media?	Try known good media. See the <i>HP LaserJet Printer Family Paper Specifications Guide</i> .
Where does the leading edge of the first sheet of paper in the printer's paper path stop when a jam occurs? Are any sheets of paper physically damaged or torn?	Attempt to duplicate. See "Paper Path Test" on page 415. Inspect the paper path and all paper path mechanical assemblies prior to the leading paper jam.
Is the customer loading the paper trays correctly?	Observe the customer loading the paper. Do not fan the paper. See proper paper handling procedures in the <i>HP LaserJet Printer Family Paper Specifications Guide</i> .
Is the customer overfilling the paper trays?	Make sure that the paper is NOT over the maximum fill marks in the paper trays. Observe the customer loading paper in the trays.

Table 7-25. General Paper Path Troubleshooting Questions (continued)

Problem	Action
Are the paper tray guides set correctly?	Make sure that the Tray 2 and 3 left-side paper fence is set correctly at both the front and rear of the tray. Make sure that the front fence is locked into the correct position. For Tray 4, make sure that all adjustments are set correctly: front, back, and side at the top and bottom of the tray.
Does the printer need cleaning?	Inspect the paper path and paper path rollers. See "Cleaning the Printer and Accessories" on page 88.
When was the User Maintenance performed on the printer?	From the Configuration Page, determine the number of pages since the last maintenance (see figure 7-7 on page 343). The Printer Maintenance Kit should be installed every 350,000 images.

Paper Path Test

Using the error trend information from "Display" on page 336, you can verify a specific printer paper path with the paper path test. You must first set the desired paper destination in the configuration menu and then select the paper path test. The paper path test menu will allow you to select the desired paper source and number.

Note

If the Multibin Mailbox is installed, in order to perform the paper path test, the printer must be configured to mailbox mode. If the printer is not in mailbox mode, ask the JetAdmin administrator to change the configuration to mailbox mode to complete this test.

To perform a paper path test:

- 1 Press **MENU** until `INFORMATION MENU` appears.
- 2 Press **ITEM** until `PRINT PAPER PATH TEST` appears.
- 3 Press **SELECT**.
- 4 Press **+** or **-** until the desired input tray appears.
- 5 Press **SELECT**.
- 6 Press **+** or **-** until the desired output bin appears.
- 7 Press **SELECT**.
- 8 Press **+** or **-** until the desired duplex mode appears.
- 9 Press **SELECT**.

10 Press **+** or **-** to choose the desired number of copies.

11 Press **SELECT**.

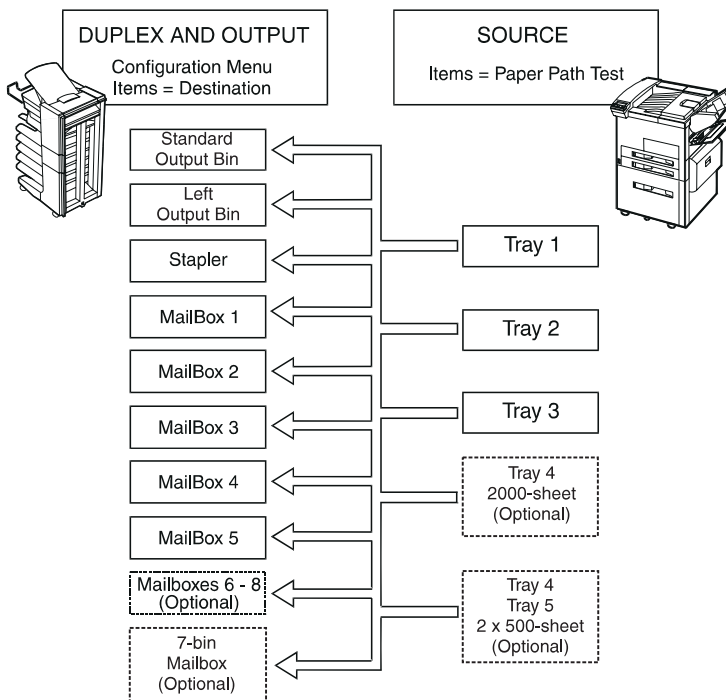

Figure 7-13 Paper Path Test Source and Output Selection

Customer Print Job

Ask the customer to send a print job from the problem source(s) to the problem destination(s). Try to recreate the paper jam errors by having the customer do typical print jobs and the type of print job that has been causing the paper jams.

When verifying print jobs, make sure that all of the settings are selected as desired. Keep in mind that application settings take priority over driver settings, which take priority over the printer control panel settings. If a single setting is not present in the application, but is set in the driver, that will override the front panel settings.

Note

JetAdmin does have capabilities to override paper types and sizes and certain conditions. See the *HP LaserJet 8000, 8000 N, 8000 DN, and HP Mopier 240 Printers User Guide* for more information.

Clearing Paper Jams

Note

Open and close all printer covers to clear the paper jam message. After removing a sheet of paper, you may need to check other areas to make sure that all paper has been removed.

All portions of a jammed piece of paper must be removed or you may run into repeated jams.

If the jam persists, try the following:

- If you have PostScript installed, use the `JAM RECOVERY=ON` menu item under the PostScript Menu. The printer will attempt to automatically recover from paper jams.
- Execute a formfeed from the computer or the printer's control panel. A formfeed may flush any paper or envelopes left in the printer.
- Check to make sure you have located and removed all scraps of paper from inside the printer.
- Use the Event Log Page and Event Log Codes to aid you in isolating where the errors are occurring.

Clearing Repeated Paper Jams

- 1 Check to see that media is correctly loaded in trays and that all width guides are correctly set (not skewed).
- 2 Try turning over the stack of paper in the tray. If you are using letterhead paper, try printing from Tray 1.
- 3 Do not use previously printed paper or torn, worn, or irregular paper.
- 4 Check the media specifications. If it is outside of the recommended specifications, problems may occur.
- 5 Printer may be dirty. Clean the printer as described in the first section of this chapter.
- 6 Check that paper loaded in Tray 1 is NOT longer than 17.7 inches (450 mm) or wider than 11.7 inches (297 mm). (These are the maximum dimensions that the printer can feed; otherwise the printer will jam.)
- 7 Make sure that Tray 4 and Tray 5 are set for the size of paper installed and that the tray is not overloaded with paper.

Diagnostics on Accessories

2 x 500-sheet Input Tray Standalone Diagnostics

The standalone diagnostics are designed to test the 2 x 500-sheet Input Tray's motors, functionality, and sensors. You will need a power cord, a #2 Phillips screwdriver, and a small flatblade screwdriver for the DIP switches.

Table 7-26. DIP switch settings for troubleshooting test procedures

DIP Switch	Normal Setting	Motor Test	Standalone Running Test	Sensor Tests
1	Off	On	On	Off
2	Off	On	Off	Off
3	Off	Off	Off	On
4	Off	On	On	On

If the 2 x 500-sheet Input Tray is working properly, it picks paper up from the tray and feeds it into the VTU, while the bottom service LED flashes regularly every 0.5 seconds.

The DIP switch is on if it is set to the top.

The DIP switch is off if it is set to the bottom.

Note

To go from one test to another or to change the DIP switch settings, set the blue power supply switch to Operational Mode (push in). Reset the DIP switches on the Controller PCA, and then switch the power supply back to Diagnostic Mode (pull out) to enable the new diagnostic test.

2 x 500-sheet Input Tray Motor Test

This test verifies that the three motors on the 2 x 500-sheet Input Tray are functioning properly.

- 1 Identify the Back Cover (opposite side from tray door). Remove the 4 screws in the Back Cover. Remove the Back Cover.
- 2 Pull open Trays 4 and 5, and open the Vertical Transfer Unit (VTU).
- 3 Set the DIP switches on the Controller PCA to Motor Test Mode. (See table 7-26 on page 418 for an explanation of the DIP switch settings.)
- 4 To turn the power supply switch to Diagnostic Mode, pull out on the blue handle.
 - If the motors are working properly, you will hear them as they rotate continuously.
 - If the motors do not rotate, replace the corresponding field-replaceable unit: either the Paper Pickup Assembly, the VTU, or the Paper Deck Drive Assembly.
- 5 To stop the test, set the power supply switch back to Operational Mode (push in), and reset the DIP switches on the Controller PCA to the off position (see table 7-26 on page 418).

2 x 500-sheet Input Tray Standalone Running Test

This test verifies that the 2 x 500-sheet Input Tray is functioning properly. For this test, use the LED located on the Controller PCA. (See table 7-27 on page 421 for an interpretation of the LED patterns.)

CAUTION

If the 2 x 500-sheet Input Tray is underneath the printer, paper jams may occur because the printer will not pick up the paper. To prevent excessive paper jams during this test, feed only 6 to 8 pages.

- 1 Make sure that there is paper in both trays.
- 2 Set the DIP switches on the Controller PCA for standalone running mode (see table 7-26 on page 418 for an explanation of the settings).
- 3 To test Tray 5, open Tray 4.

- 4 To set the power supply switch to Diagnostic Mode, pull the blue power supply switch outward. The motors will start. Paper should now be lifted from the tray and fed through the VTU. The service LED flashes regularly every 0.5 seconds.
 - If the unit does not work properly, the service LED on the Controller PCA flashes in a pattern that indicates the problem. (See table 7-27 on page 421 for an interpretation of the LED patterns.)
- 5 To stop the test, set the power supply switch back to Operational Mode. Open the VTU, and remove any media from the paper path.
- 6 To test Tray 4, close Tray 4 and open Tray 5. Repeat step 4.
- 7 To stop the test, set the power supply switch back to Operational Mode, and set the DIP switches on the Controller PCA to the off position (see table 7-26 on page 418). Open the VTU, and remove any media from the paper path.

2 x 500-sheet Input Tray Sensor Test

This test manually activates the sensors on the 2 x 500-sheet Input Tray to test if they are working properly.

- 1 Set the DIP switches on the Controller PCA for sensor test mode. (See table 7-26 on page 418 for an explanation of the settings.)
- 2 To set the power supply switch to Diagnostic Mode, pull the blue power supply switch outward.
- 3 To manually activate each sensor, press it in with your finger.
 - When you activate the sensor, the service LED on the Controller PCA comes on. When you release the sensor, the LED goes off.
 - If the LED does not come on, there is a problem with the sensor. Replace the corresponding field-replaceable unit.
- 4 To stop the test, set the power supply switch back to Operational Mode, and set the DIP switches on the Controller PCA to the off position (see table 7-26 on page 418).

Note

Be sure to turn the power supply off, and set all the DIP switches to the off position (normal settings) when you finish the diagnostics or the printer will not work properly. Replace the back cover.

2 x 500-sheet Input Tray LED Status Interpretation

If the 2 x 500-sheet Input Tray is working properly, it will pick up paper from the tray and feed it through the VTU and the bottom service LED will flash regularly every 0.5 seconds.

Table 7-27. Patterns of LED flashing (2-second pause between each pattern)

Long (1 sec)	Short (0.3 sec)	Meaning	Recommended Action
3	1	Lifter malfunction	Verify that the tray lifts up freely by lifting it by hand. Verify that the paper size plates are installed correctly (in the same corresponding slots) and are not bent. If neither of these is the problem, replace Tray 4 or 5.
2	1	Registration sensor delay jam	The media did not reach the sensor. Open the VTU door, and remove the media. Replace the paper feed (VTU) assembly or the paper pickup assembly.
2	2	Registration sensor stationary/jam initial jam	Open the VTU door, and remove the media. Check the sensors, and replace the corresponding field-replaceable unit.
2	3	Jam sensor delay jam	The media did not reach the sensor. Open the VTU door, and remove the media. Replace the paper feed (VTU) assembly or the paper pickup assembly.
2	4	Jam sensor stationary jam/initial jam	Open the VTU door, and remove the media.
1	1	The VTU door is open	Close the door.
1	2	Trays 4/5 are open Wrong paper size loaded	Close the tray(s). Check the sensors. Load the correct size of paper. Check the sensors.
1	3	No paper in trays 4/5	Load paper. Check the sensors.

Note

If the LEDs will not come on, replace the paper deck PCA or the universal power supply assembly.

7-Bin Tabletop Mailbox Standalone Diagnostics

The standalone diagnostics are designed to test the accessory's motors, functionality, and sensors. You will need a power cord, a #2 Phillips screwdriver, and a small flatblade screwdriver for the DIP switches.

Note

To change from one test to another or change the DIP switch settings, push the blue power supply switch in (off position), then set to the new test positions.

- 1 Identify the back cover. The paper trays are on the right. Remove the back cover by removing the 2 screws.
- 2 Identify the interlock switch. This black switch is set when the 7-bin Tabletop Mailbox comes into contact with the printer. (Look on opposite side from the paper trays.) This interlock can be defeated by holding it in with a finger or a piece of tape.
- 3 Identify the DIP switch, SW1 (upper-right corner of the controller PCA).
- 4 Identify the service LED, LED1 (near the C-link connectors).

Note

The DIP switch is on if it is to the right. The DIP switch is off if it is to the left.

Table 7-28. DIP switch settings for troubleshooting test

DIP Switch	Normal Settings	Motor Test	Standalone Mailbox	Running Test Stacker	Sensor Test
1	Off	On	On	Off	Off
2	Off	On	Off	On	Off
3	Off	Off	On	Off	On
4	Off	On	Off	On	On

7-bin Tabletop Mailbox Motor Test

This test allows you to verify the functionality of the main motor, face-down solenoid, and face-up diverter solenoid.

- 1 The top cover and paper access door must be closed to perform this test.
- 2 Set the DIP switches for the motor test (see table 7-28).
- 3 Pull out the power supply switch to the test position.
- 4 Press and hold in the interlock switch. A self-test should be performed, then the main motor will start moving continuously until the interlock switch is released. The service LED will flash every 0.5 seconds. If any other pattern results with the service LED, see table 7-29 on page 424 for the possible causes.
- 5 Push in the power supply switch to the normal position.

7-bin Tabletop Mailbox Standalone Running Test

This test allows you to feed paper into the unit to test the paper path without a connection to the printer. You can configure either the Mailbox Mode or the Stacker Mode to ensure the paper path is working properly.

- 1 The top cover and paper access door must be closed to perform this test.
- 2 Set the DIP switches for the standalone running test in either Mailbox Mode or the Stacker Mode (see table 7-28 on page 422).
- 3 Pull out the power supply switch to the test position.
- 4 Press and hold in the interlock switch. Perform a self-test. Then manually start feeding paper.
 - In Mailbox Mode, the unit will deliver paper to all bins, starting with the left output bin, then down to the bottom bin.
 - In Stacker Mode, the unit will stack paper starting at the bottom bin until the top-of-stack is reached on each bin.
- 5 If problems are found, the possible cause will be indicated by the Service LED (see table 7-29 on page 424).
- 6 Push in the power supply switch to the normal position.

7-bin Tabletop Mailbox Sensor Test

This test allows you to check if all unit sensors are working properly. By activating any unit sensor flag, the service LED should turn on.

- 1 Make sure that all bins are empty to perform the sensor test.
- 2 Set the DIP switches for the sensor test (see table 7-28 on page 422).
- 3 Do NOT press the interlock switch in at this time.
- 4 Pull out the power supply switch to the test position.
- 5 Make sure that the service LED is off.
- 6 Manually activate any sensor flag. The service LED should turn on if the sensor is functional.

Note

To test the top cover or paper access door sensors, you need to press the interlock switch and simultaneously open and close each cover. A self-test should be performed, and the LED should remain on.

Be sure to turn the power supply off and set all the DIP switches to the off position (normal settings) when you finish the diagnostics or the printer will not work properly. Replace the back cover.

Table 7-29. Patterns of Flashing LEDs

Long	Short	Meaning	Recommended Action
3	1	Paper exit solenoid malfunction	<ul style="list-style-type: none">● Perform the motor test to check the solenoids.● Perform the sensor test.● Replace the sensor bin full PCA, solenoids, or controller board.
2	1	Initial jam	<ul style="list-style-type: none">● Open the top cover and paper access door to remove any remaining paper, then perform a sensor test.● Replace the sensor bin full PCA or controller PCA.
2	2	Jam without delivery notice	<ul style="list-style-type: none">● Open all covers and doors in the device, and remove any jammed paper.● Check for paper jammed in the printer.● Try printing again.

Table 7-29. Patterns of Flashing LEDs (continued)

Long	Short	Meaning	Recommended Action
2	3	Entry sensor delay	<ul style="list-style-type: none"> ● Open all covers and doors in the device, and remove any remaining media.
2	5	Face-up sensor delay	<ul style="list-style-type: none"> ● Check each bin output. ● Perform a sensor check.
2	7	Reversing area delay	<ul style="list-style-type: none"> ● Check the sensor flag, the optical sensor, or cabling. ● Replace the sensor PCAs.
2	9	Vertical sensor delay	<ul style="list-style-type: none"> ● Replace the controller PCA.
2	4	Entry sensor activated too long	<ul style="list-style-type: none"> ● Open the top and back covers, and remove any remaining media. ● Check each bin output.
2	6	Face-up sensor activated too long	<ul style="list-style-type: none"> ● Perform a sensor check. ● Check the sensor flag, the optical sensor, or cabling.
2	8	Reversing area sensor activated too long	<ul style="list-style-type: none"> ● Replace the sensor PCAs. ● Replace the controller PCA.
2	10	Vertical sensor activated too long	
1	1	Door open or interlock switch deactivated	<ul style="list-style-type: none"> ● Close the top cover and paper access door. ● Firmly attach the 7-bin Tabletop Mailbox to the printer. ● Perform a sensor check. ● Check the bin full and interlock sensor PCA, cabling, and controller PCA.
1	2	Bin full when running the standalone test	<ul style="list-style-type: none"> ● Remove paper from all the bins.

General Troubleshooting Information

Miscellaneous Problems and Solutions

The following lists symptoms and typical solutions to those problems.

Abnormal noises are evident, such as grinding or chattering when main motor energized.

From the EP Area:

- 1 Replace the toner cartridge.
- 2 Replace the Main Gear Assembly. See “Main Gear Assembly” on page 191 for instructions.

From Tray 2 or 3:

- 1 Verify proper paper loading, acceptable media.
- 2 Inspect the “fingers” on the paper trays to ensure proper paper size detection.
- 3 Replace the Paper Input Unit. See “Paper Input Unit (PIU)” on page 195 for instructions.
- 4 Replace the Main Gear Assembly. See “Main Gear Assembly” on page 191 for instructions.

From 2000-sheet Input Tray:

- 1 Check the white plastic bushing on Tray 4. The bushing is located on the Tray 4 main drive assembly. The bushing accepts the Tray 4 pilot pin when Tray 4 is closed. Replace if broken.
- 2 Replace 2000-sheet Input Tray Vertical Transfer Assembly.
- 3 Replace the 2000-sheet Input Tray Main Drive Assembly. See the *HP LaserJet 8000, 8000 N, 8000 DN, and HP Mopier 240 Printers Service Manual Supplement for Paper-handling Accessories* for instructions.

From Multibin Mailbox:

- 1 Verify pawls are riding above the output rollers (see figure 7-14 on page 433).

Will not feed from Tray x when printing from application; paper path test works fine.

Verify the correct paper size:

- 1 Tray 1: From Control Panel Paper Handling Menu.
- 2 Tray 2, 3, 4, or 5: Remove and reseal the paper fences in the correct position in the failing tray.

Excessive Image Skew

- 1 Remove and reseal the paper fences (front fence in paper trays).
- 2 Image Skew Specifications:
 - 1 mm over 260 mm length
 - First line to leading edge 5.0 +/- 2.5 mm
 - Text Stretching 1% simplex 1.5% duplex

Envelope

- Skew 6.0 over 260 mm length
- First line on envelopes to leading edge/ left margin 15 +/- 4.5 mm

Loses Page Counts, Serial Number.

Make sure that the serial number listed on the Configuration Page is AAXYY9999. Print the Event Log and look for a 68 error with a page count of zero. Using the Event Log, take the page count shown at the top of the page and add the page count from any/all errors preceding any 68 errors. Use this number and enter it into the Control Panel from Service Mode.

Will not print from 2000-sheet Input Tray or 2 x 500-sheet Input Tray.

- 1 Print the Configuration Page. Make sure that the Paper Handling Controller and 2000-sheet or 2 x 500-sheet Input Tray are listed in the Paper Handling Options section.
- 2 Verify that power is supplied to the 2000-sheet or 2 x 500-sheet Input Tray.

- 3 Run a paper path test from Tray 4 or 5. If the test is successful, the paper size detection switches may have failed or an incorrect size is specified in the application software.
- 4 Replace the Paper Handling Controller if it is not shown on the Configuration Page.
- 5 Verify that the C-link cables are connected as shown in figure 7-8 on page 346.
- 6 Reseat the C-link Cable, and inspect for pushed in pins.
- 7 Replace the C-link Cable.
- 8 Replace the 2000-sheet or 2 x 500-sheet Input Tray Controller PCA.

Print Voids on pages after coming out of PowerSave mode.

Turn PowerSave mode off (PowerSave is an item under the Configuration Menu) and retry.

Jams when printing envelopes, transparencies, or labels to the Multibin Mailbox or Stapler.

The Multibin Mailbox does not support these media. Direct these media to the Left Output Bin (top bin of the Multibin Mailbox).

Stops printing and hangs on certain jobs.

- 1 Remove any non-HP Memory DIMMs and retry.
- 2 Set to 300 DPI and retry.

Top 2/3 of portrait page is lighter.

- 1 Replace the Toner Cartridge and retry.
- 2 Replace the Transfer Guide.

Will not print to Mailbox.

- 1 Print the Configuration Page. Make sure that the Paper Handling Controller, 2000-sheet Input Tray, and Multibin Mailbox are listed in the Paper Handling Options section.
- 2 Replace the Paper Handling Controller if it is not shown on the Configuration Page.

- 3 Inspect the C-link Cables for pushed out pins.
- 4 Replace the C-link Cables.
- 5 Connect the Multibin Mailbox directly to the printer. If it is now recognized on the Configuration Page, replace the 2000-sheet Input Tray Controller.
- 6 Replace the Multibin Mailbox Controller.
- 7 Replace the Multibin Mailbox External Power Supply.
- 8 Replace the entire Multibin Mailbox.

Wrinkling Envelopes

- 1 Place the Fusing Levers in up position and retry the envelopes.
- 2 Try new media. Make sure that the envelopes are within specifications. See the *HP LaserJet Family Paper Specifications Guide*.

Poor Fusing

- 1 Make sure that the Fusing Levers are in the down position for cut sheet paper.
- 2 Try new media. Make sure that the media is within specifications.
- 3 Make sure that the AC power does not fluctuate out of range during the print cycle. See table 1-5 on page 9. See the *HP Laserjet Family Paper Specifications Guide*.

Feeds from incorrect tray when selecting different media for the first page of the job.

First you must determine if it is a hardware or a software issue. Run a paper path test from each paper tray to eliminate the hardware. See page 415.

If the paper path test fails, troubleshoot the error message. Make sure that the most current HP driver is installed.

Select the **Print Quality Tab** from the printer driver. Click on **About**. Make sure that the driver revision is the most current. You may find the most current driver in various electronic locations. Check with HP Service and Support.

If the paper path test works, it may be a software or user related issue. Perform the following steps:

- 1 Define the media types that are loaded in each paper tray. This can be done from either JetAdmin or the front control panel of the printer.

From JetAdmin

- 1 Select the Trays tab.
- 2 Select the correct media type for each tray listed.
- 3 Click on **OK** save your changes and exit JetAdmin.

From the Control Panel

Note

To set the paper type for Tray 1, set `TRAY 1 MODE=CASSETTE` from the Paper Handling Menu.

- 1 From the Paper Handling Menu, press **ITEM** to select a specific tray.
- 2 Press **+** until you get to the correct type of media.
- 3 Press **SELECT**.
- 4 Repeat this step for each paper tray.
- 5 Press **Go**.
- 6 From inside your application, choose the page setup option for that application.
- 7 Select the paper source / type option.
- 8 Select the correct media source / type for the first page.
- 9 Select the correct media source / type for all other pages.

Note

You must have the HP LaserJet 8000 printer selected in your application in order for your application to provide you with the correct paper tray and media type selections.

CAUTION

Do not make changes to the driver unless the application does not provide this option. Print job settings selected through your application always override settings made through the printer driver. Printer settings made in the application or print driver always override the corresponding setting made on the printer Control Panel.

- 10 Print the document.

Paper Curl

Paper curl is inherent to the laser printing processes, as it occurs when paper is subjected to heat. Paper curl tends to relax as the paper cools while resting on a flat surface. The specification for maximum paper curl when the paper is lying flat before print is 0.2 inches (5 mm).

Although paper curl cannot be totally eliminated, some steps can be taken to lessen its impact, as suggested in the following table.

Table 7-30. Paper Curl

Possible Cause	Recommended Action
1. Paper Path	Try using Tray 1 and output the paper to the left output bin.
2. Paper Surface	The recommended printing surface of the page is usually marked on the end of a ream of paper, indicated by a small arrow and the phrase "print this side first." Load paper in Tray 1 with the recommended printing surface facing up (facing down in Trays 2, 3, 4, and 5).
3. Paper Storing and Handling	Over time, paper assumes the characteristics of its storage environment (in a humid environment, paper absorbs moisture; in a dry environment, paper loses moisture). Paper with higher moisture content will tend to curl more. Evaluate the storage conditions of the paper.
4. Paper Type	All paper is manufactured differently (different textures, moisture content, drying processes, composition, etc.). Change the type of paper being used and re-evaluate the paper curl results.

Diagrams

This section contains the following diagrams:

- Figure 7-14, “Printer Sensors and Switches,” on page 433
- Figure 7-15, “Printer Motor, Clutches, and Solenoids,” on page 434
- Figure 7-16, “DC Controller Inputs and Outputs (1 of 5),” on page 435
- Figure 7-17, “DC Controller Inputs and Outputs (2 of 5),” on page 436
- Figure 7-18, “DC Controller Inputs and Outputs (3 of 5),” on page 437
- Figure 7-19, “DC Controller Inputs and Outputs (4 of 5),” on page 438
- Figure 7-20, “DC Controller Inputs and Outputs (5 of 5),” on page 439
- Figure 7-21, “Mailbox with Stapler Wiring Diagram,” on page 440

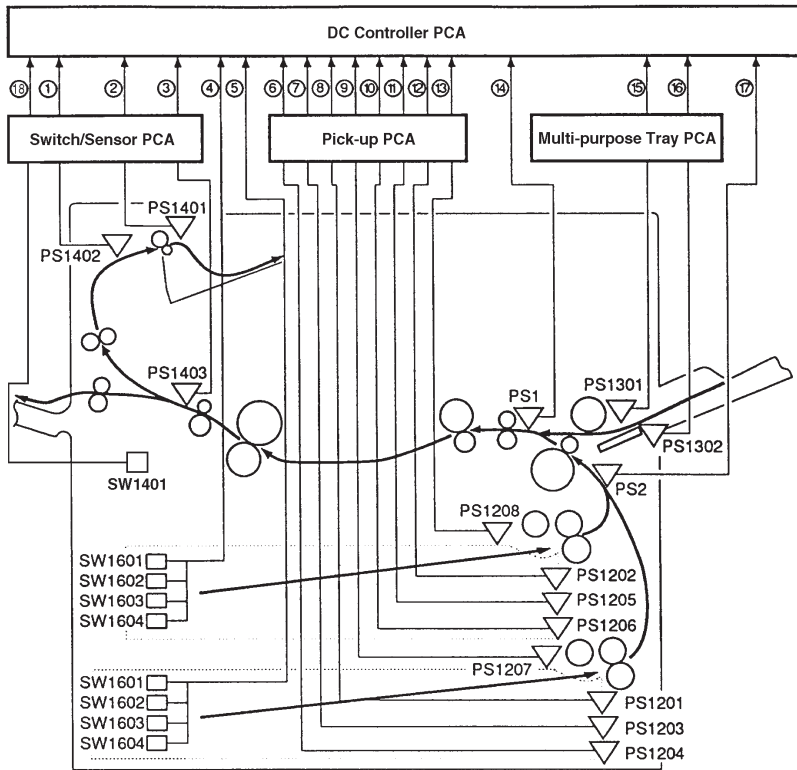

- | | |
|--|--|
| ① : FACE-DOWN TRAY DELIVERY SENSE signal (/FDOUTS) | PS1: Registration paper sensor |
| ② : FACE-DOWN TRAY PAPER FULL SENSE signal (/FDDULS) | PS2: Pick-up unit paper sensor |
| ③ : FUSING UNIT DELIVERY SENSE signal (FPOUTS) | PS1201: Tray 3 present sensor |
| ④ : TRAY 2 PAPER SIZE SENSE signal | PS1202: Tray 2 present sensor |
| ⑤ : TRAY 3 PAPER SIZE SENSE signal | PS1203: Tray 3 paper-level sensor 1 |
| ⑥ : TRAY 3 PAPER-LEVEL SENSE signal 1 (LVPS1) | PS1204: Tray 3 paper-level sensor 2 |
| ⑦ : TRAY 3 PAPER-LEVEL SENSE signal 2 (LVPS2) | PS1205: Tray 2 paper-level sensor 1 |
| ⑧ : TRAY 3 SENSE signal (/LDECKC) | PS1206: Tray 2 paper-level sensor 2 |
| ⑨ : TRAY 3 PAPER-OUT SENSE signal (/LDECKS) | PS1207: Tray 3 paper-out sensor |
| ⑩ : TRAY 2 PAPER-LEVEL SENSE signal 1 (UPVS1) | PS1208: Tray 2 paper-out sensor |
| ⑪ : TRAY 2 PAPER-LEVEL SENSE signal 2 (UPVS2) | PS1301: Tray 1 paper present sensor |
| ⑫ : TRAY 2 SENSE signal (/UDECKC) | PS1302: Lifting plate position sensor |
| ⑬ : TRAY 2 PAPER-OUT SENSE signal (/UDECKS) | PS1401: Face-down tray paper full sensor |
| ⑭ : REGISTRATION PAPER SENSE signal (/REGS) | PS1402: Face-down tray delivery sensor |
| ⑮ : TRAY 1 PAPER SENSE signal (/MPTPS) | PS1403: Fixing unit delivery sensor |
| ⑯ : LIFTING PLATE SENSE signal (/MPTLS) | SW1601: Paper-size sensing switch |
| ⑰ : PICK-UP UNIT PAPER SENSE signal (/FEEDS) | SW1602: Paper-size sensing switch |
| ⑱ : TOP/LEFT DOOR OPEN signal (UDOORS) | SW1603: Paper-size sensing switch |
| | SW1604: Paper-size sensing switch |
| | SW1401: Doors open switch |

Figure 7-14 Printer Sensors and Switches

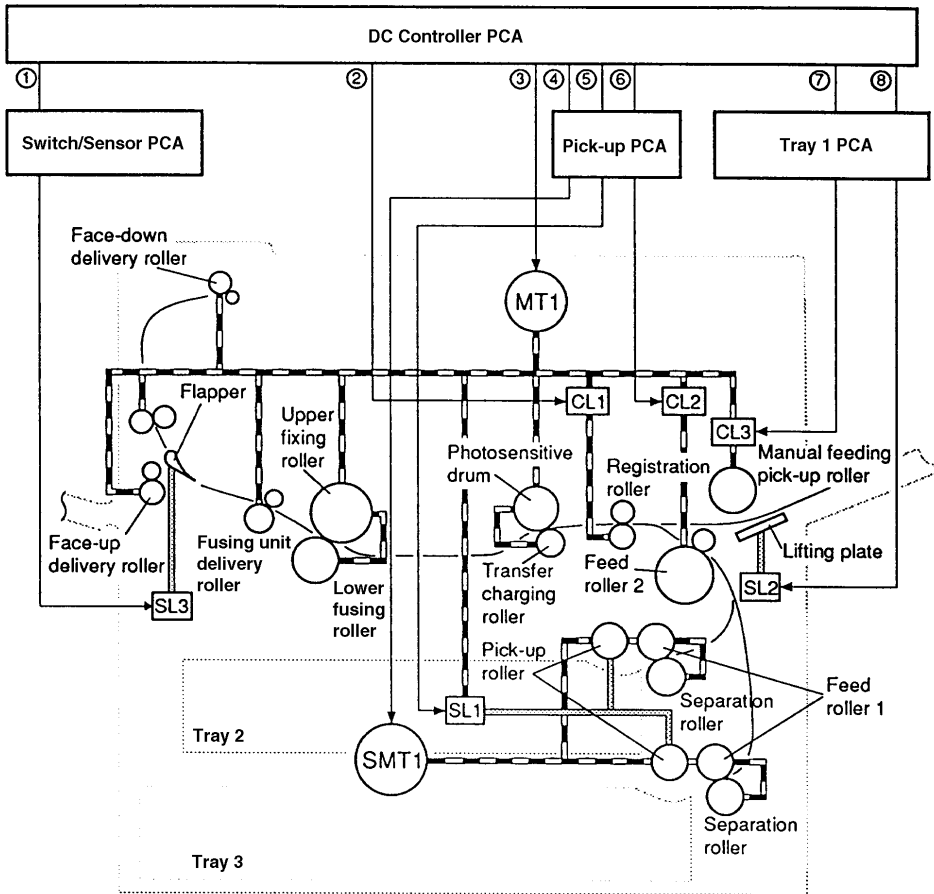

Figure 7-15 Printer Motor, Clutches, and Solenoids

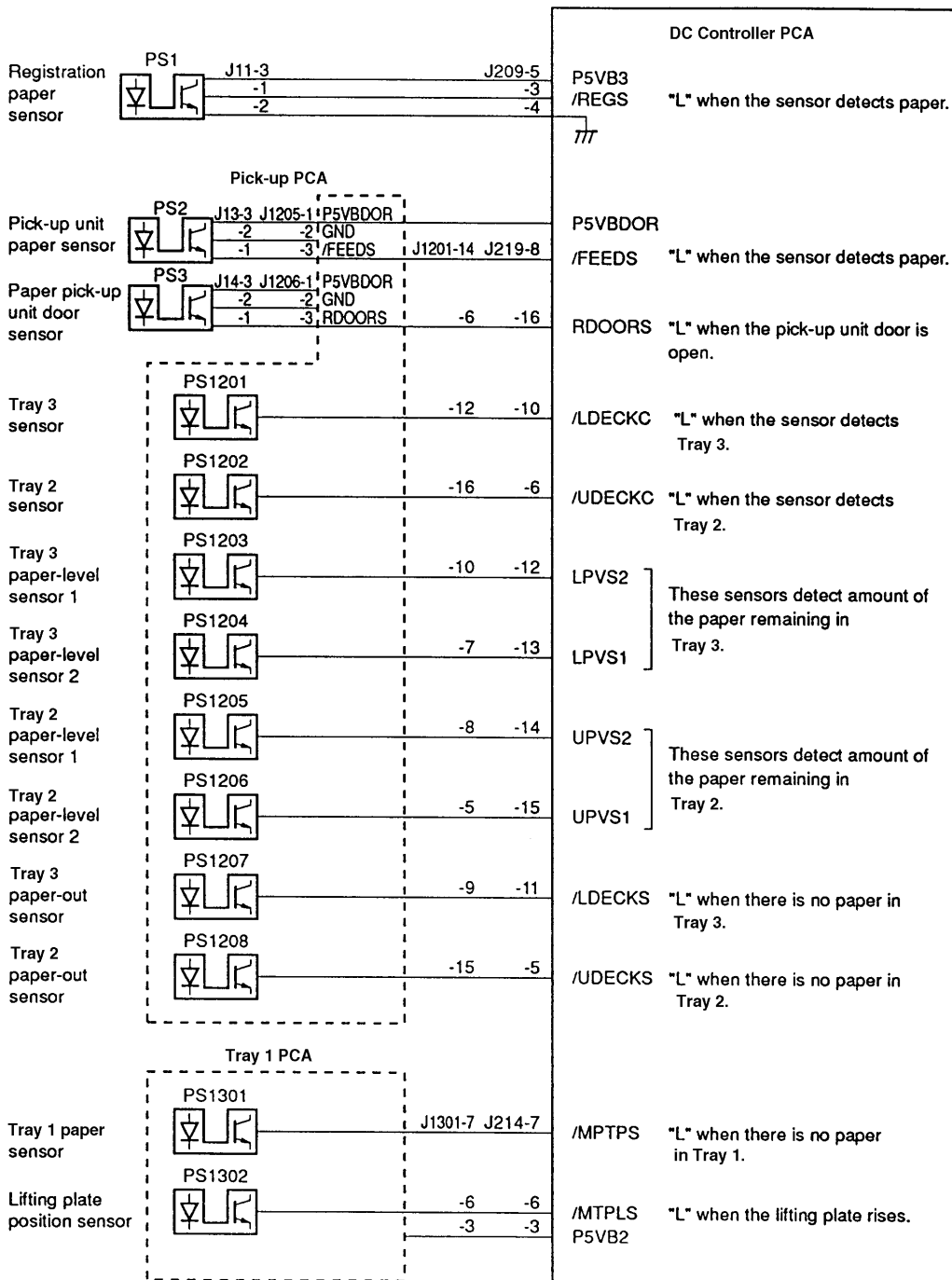

Figure 7-16 DC Controller Inputs and Outputs (1 of 5)

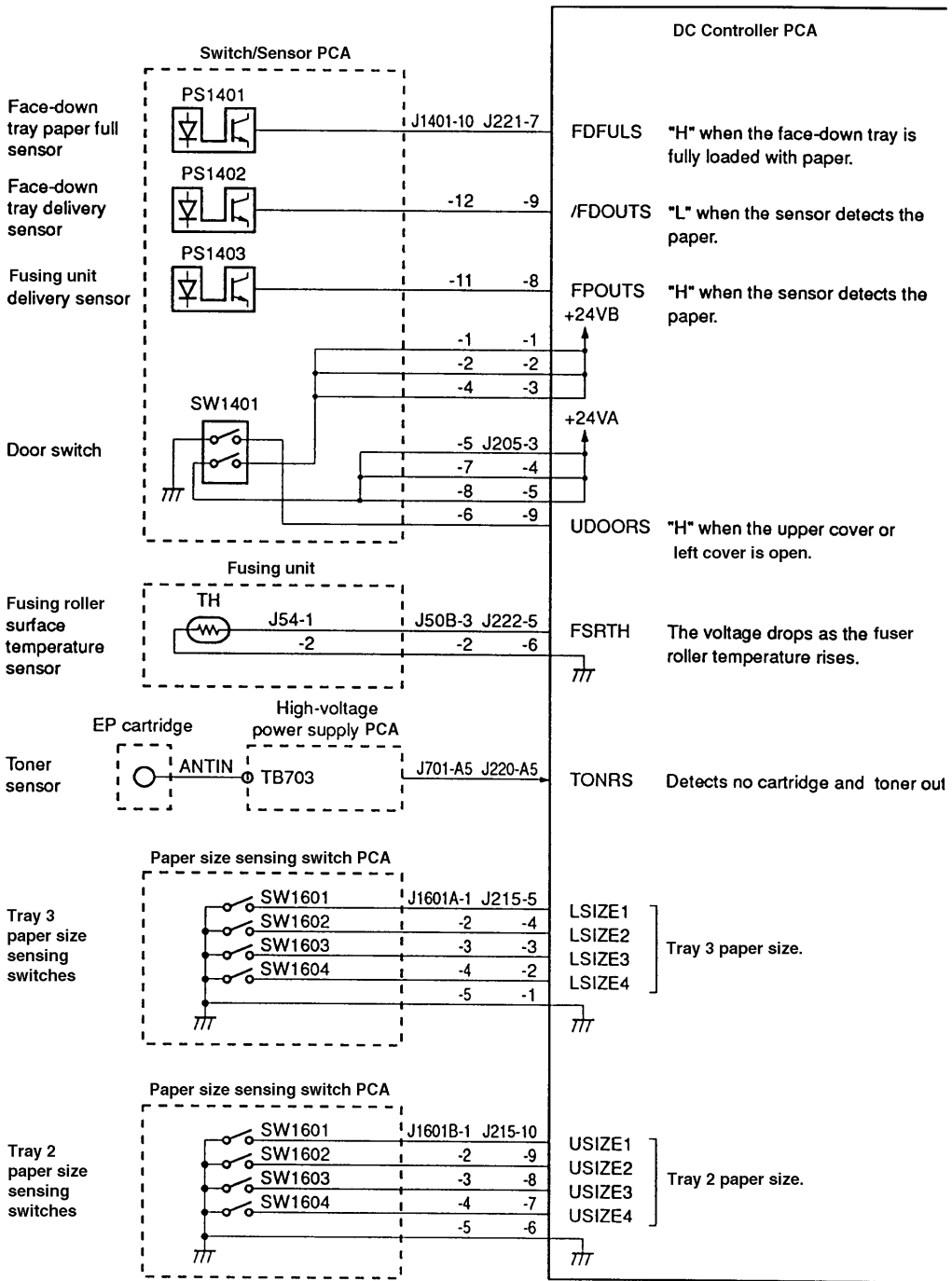

Figure 7-17 DC Controller Inputs and Outputs (2 of 5)

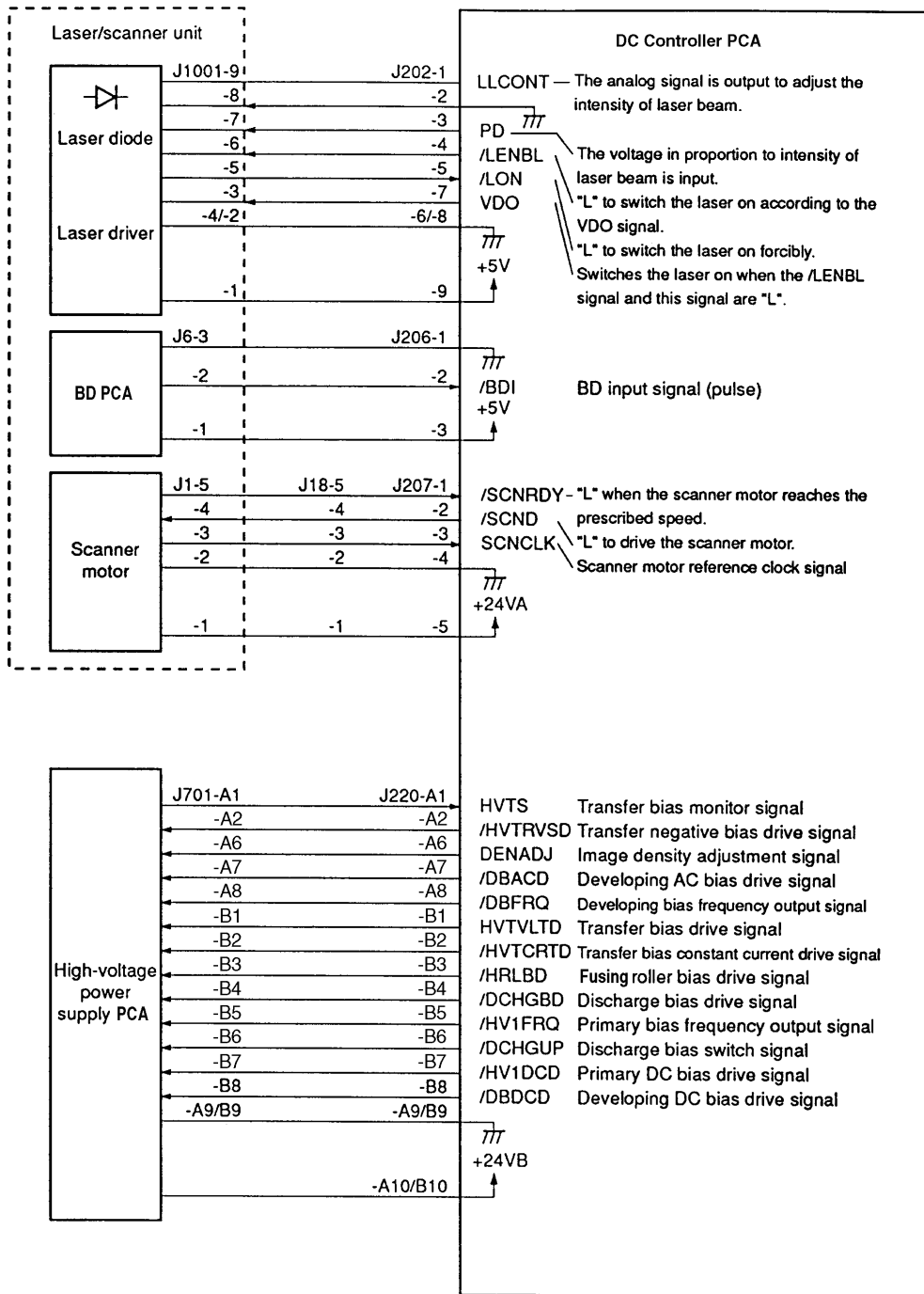

Figure 7-18 DC Controller Inputs and Outputs (3 of 5)

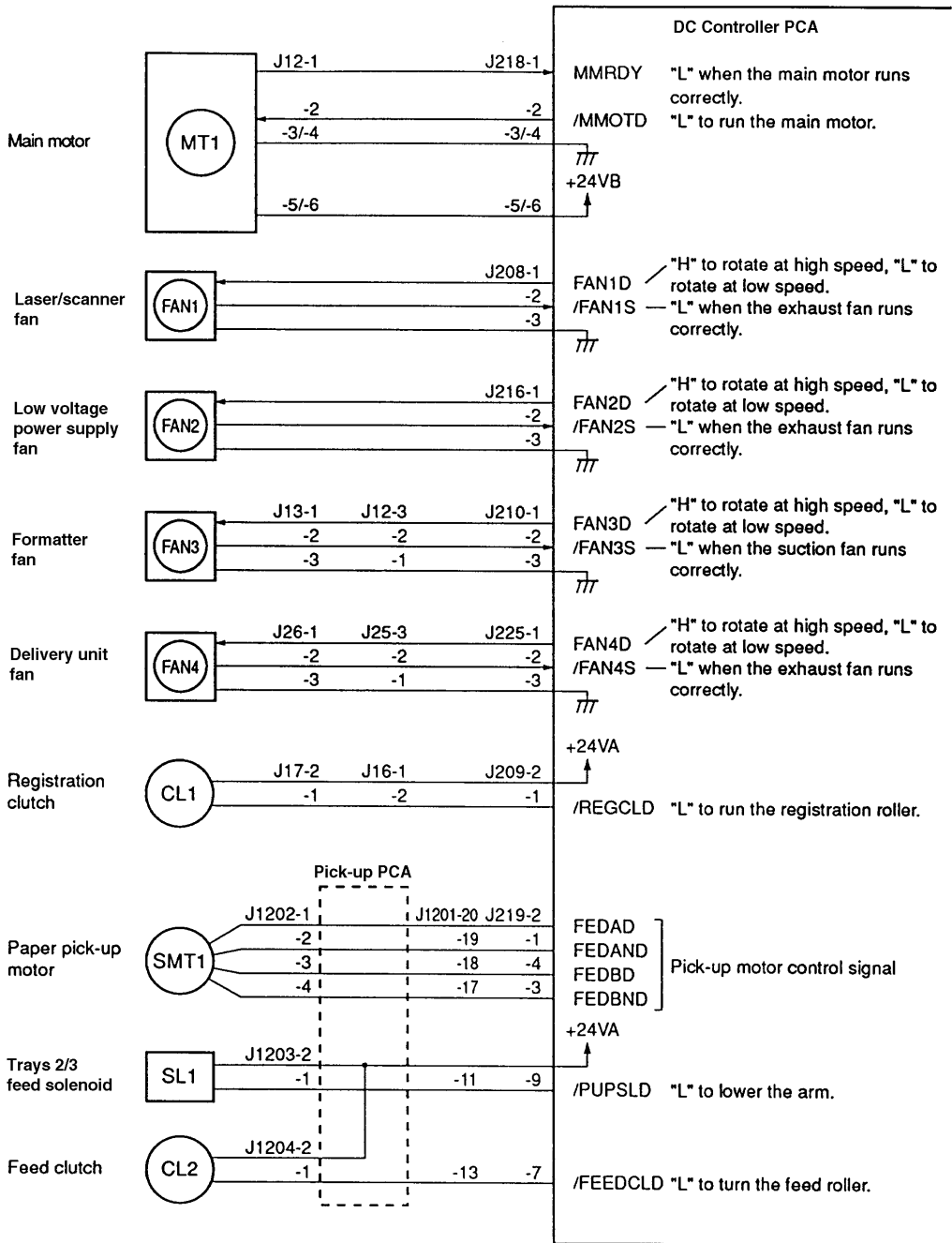

Figure 7-19 DC Controller Inputs and Outputs (4 of 5)

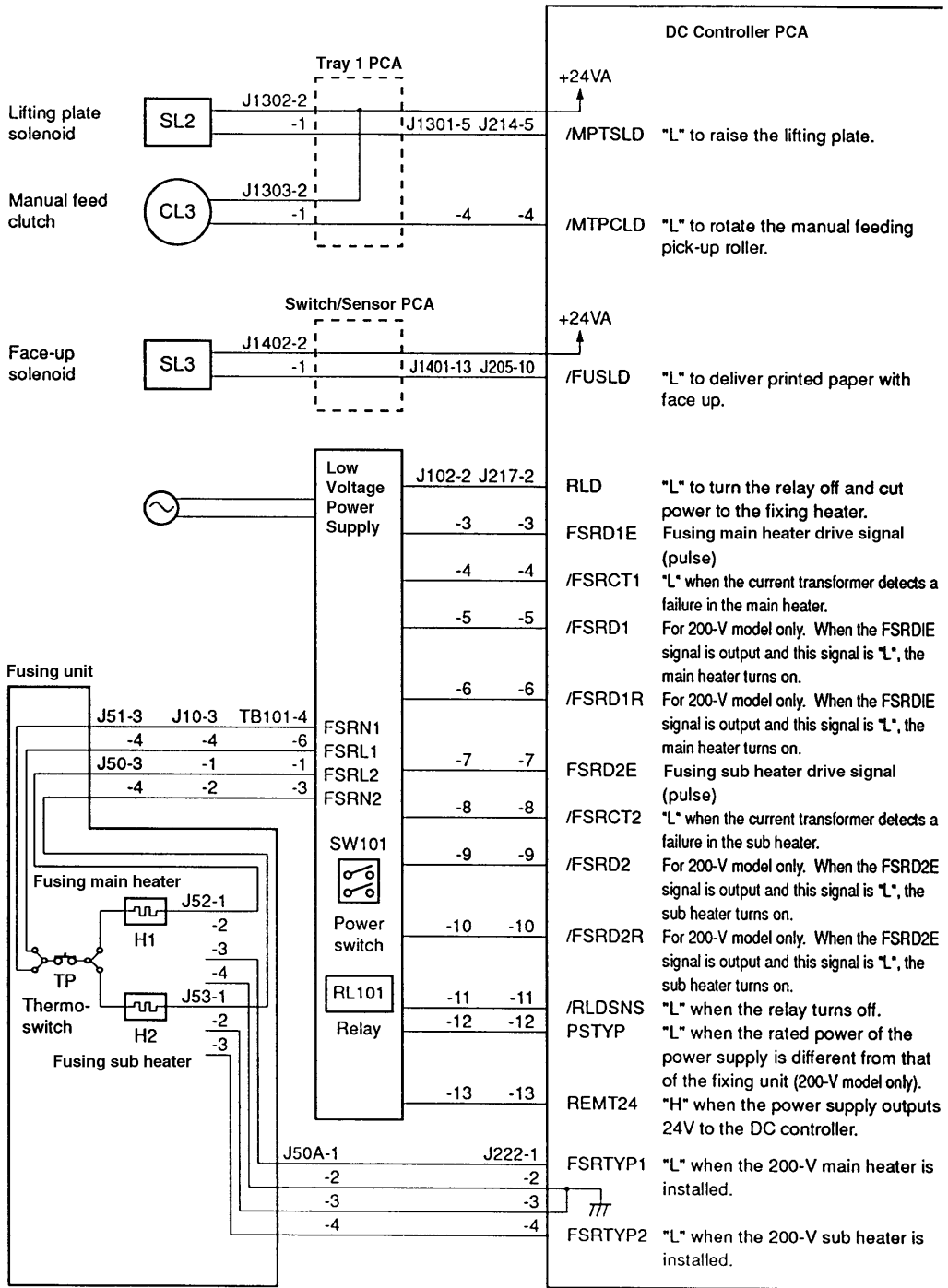

Figure 7-20 DC Controller Inputs and Outputs (5 of 5)

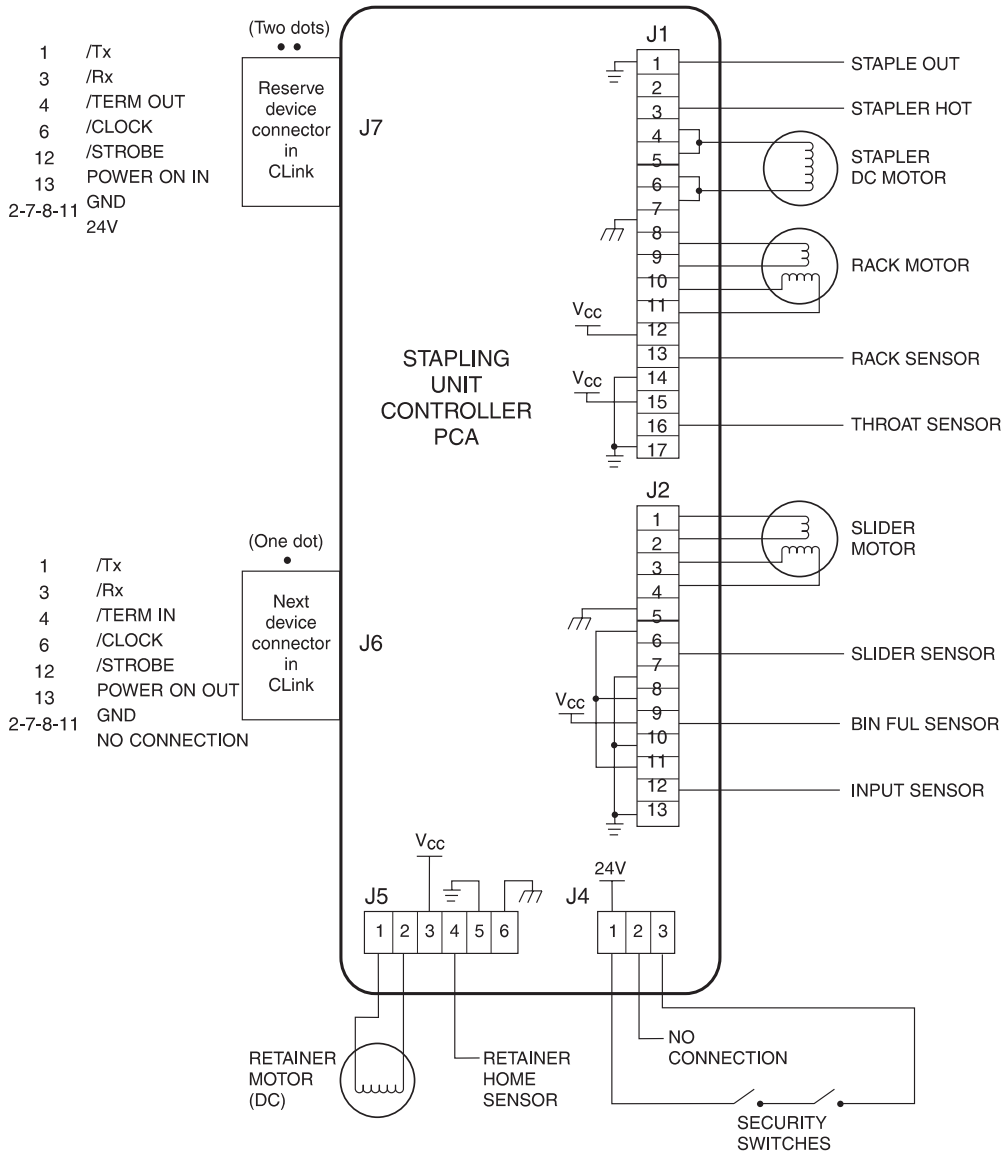

Figure 7-21 Mailbox with Stapler Wiring Diagram

8 Parts and Diagrams

Chapter contents

How to Use the Part Lists and Diagrams - - - - -	442
Accessories and Supplies - - - - -	443
Illustrations and Parts Lists - - - - -	444
Alphabetical Parts List - - - - -	467
Numerical Parts List - - - - -	475

How to Use the Part Lists and Diagrams

The figures in this chapter illustrate the major subassemblies and their component parts. (Please refer to the *HP LaserJet 8000, 8000 N, 8000 DN, and HP Mopier 240 Printers Service Manual Supplement for Paper-handling Accessories* for additional subassemblies and components.) Each table lists the reference designator (item number) for each part, the associated part number for the item, the quantity, and a description of the part.

While looking for a part number, pay careful attention to the voltage listed in the description column to ensure that the part number selected is for the correct model of printer.

Note

Parts that have no item or part number listed are not field-replaceable parts and cannot be ordered.

Ordering Parts

All standard part numbers listed are stocked and may be ordered from HP's support Materials Organization (SMO) or Support Materials Europe (SME).

Hewlett-Packard Co.
Support Materials Organization
8050 Foothills Blvd.
Roseville, CA 95678
Parts Direct Ordering 1-800-227-8164 (U.S. Only)

Hewlett-Packard Co.
Support Materials, Europe
Wolf-Hirth Strasse 33
D-7030 B"blingen, Germany
(49 7031) 14-2253

Contact your local HP Parts Coordinator for other local phone numbers.

Accessories and Supplies

The accessories, supplies, and parts listed in Chapter 1 and in the following pages are available through your local authorized HP dealer. To find a dealer near you (or if your dealer is temporarily out of stock), call the HP Customer Information Center (800) 752-0900 (U.S. Only).

Note

See Chapter 1 "Technical Assistance" for documentation and training media product numbers.

Common Hardware

See table 6-1 in Chapter 6 for a list of the common hardware used in the printer.

Illustrations and Parts Lists

The following illustrations and their associated parts tables list the field-replaceable components for this printer. Where applicable, the exchange part number is listed immediately following the original equipment part numbers. This chapter also provides two cross-reference tables of all the parts listed in this chapter: table 8-10 on page 467 lists the parts in alphabetical order, and table 8-11 on page 475 lists the parts in numerical order. Both tables are cross-referenced to the appropriate figure and reference designator in this chapter.

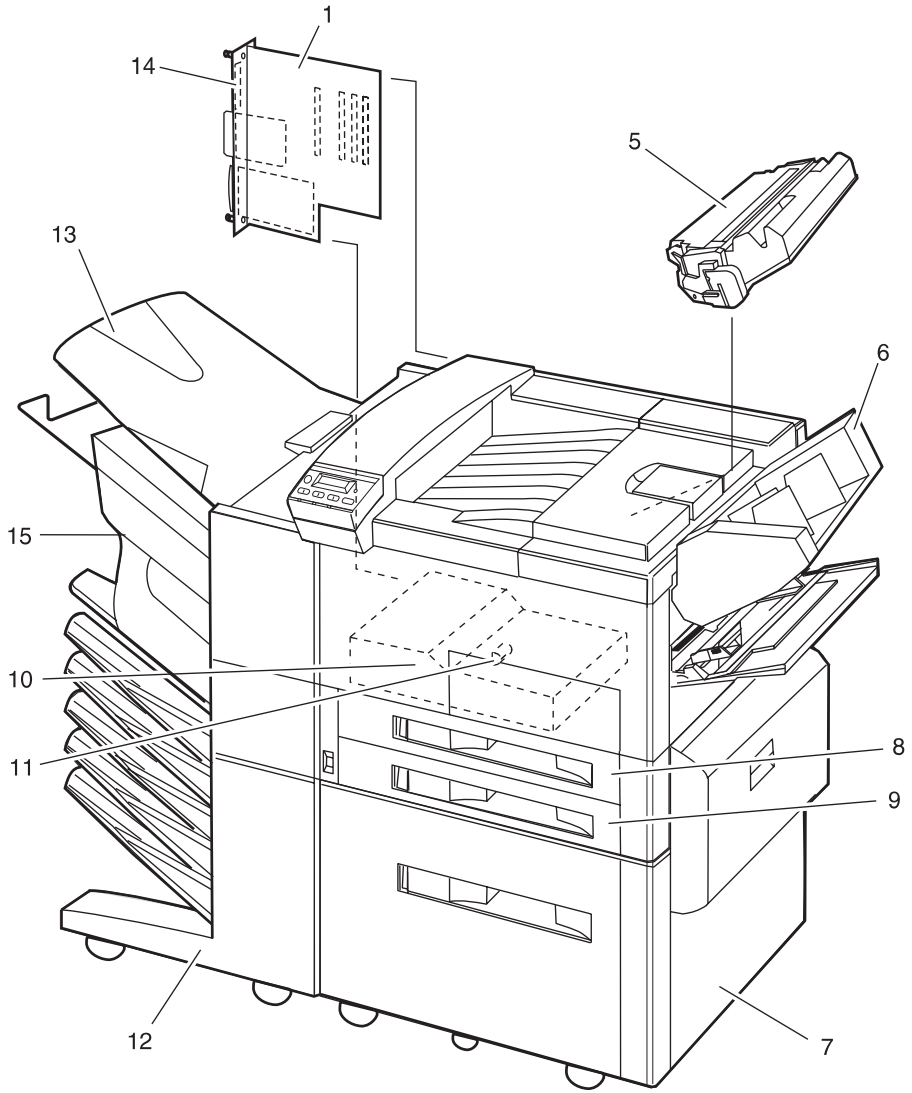

Figure 8-1 HP LaserJet 8000/N/DN or HP Mopier 240 Printer and Paper-Handling Components

Table 8-1. Printer and Paper-Handling Components

Ref	Description/Product Number	Part Number	Exchange/Service Number	QTY
01	Formatter Assembly	C4186-67901		
01A	Formatter Assembly, Exchange		C4186-69001 (ex.)	
05	Toner Cartridge/C3909A			
06	Envelope Feeder/C3765B		C3765-60501(serv.)	1
07	2000-sheet Tray (Tray 4)/C4781A or 2 x 500-sheet Input Tray (Tray 4 & 5)/ C4780A		(ex.) (serv.)	1
08	Tray 2	RG5-3951-000CN		1
09	Tray 3	RG5-3952-000CN		1
not shown	Paper Size Guide (Trays 2 and 3)	RF5-1484-000CN		1
not shown	Paper Size Guide Label (Trays 2 and 3)	RS5-8605-000CN		1
10	Duplexer/C4782A	C4782-60501	C478260501 (ex.) C3762-60501 (serv.)	1
11	Duplexer Roller 1	RB1-6822-000CN		1
12	8-bin Multibin Mailbox/C4785A or 5-bin Mailbox with Stapler/C4787A			1
13	Left Output Bin	RB1-6491-000CN		1
14	EIO Coverplate	5021-0349		3
not shown	Stapler	C4787-60500		1
not shown	7-bin Tabletop Mailbox/C4783A			
not shown	2 x 500-sheet Input Tray/C4780A			
not shown	Stand for 7-bin Tabletop Mailbox/C4784A	C4784-60500		
not shown	Packaging Kit, Printer	C3166-67905		
not shown	Packaging Kit, duplexer	C3762-60500		
not shown	Packaging Kit, 2000-sheet Tray	C3763-60500		
not shown	Packaging Kit, Multibin Mailbox	C3764-60500		
not shown	Packaging Kit, Envelope Feeder	C3765-60500		
not shown	Maintenance Kit, 100-120V/C3971B		C3971-69002 (ex.)	
not shown	Maintenance Kit, 220-240V/C3972B		C3972-69002 (ex.)	
not shown	C-link Cable Assembly 178 cm (2000-sheet Input Tray to Multibin Mailbox)	C3764-70000		
not shown	C-link Cable Assembly 61 cm (Engine to 2000-sheet Input Tray)	C3763-70000		
not shown	C-link Cable Assembly 97 cm (Multibin Mailbox to Stapler)	C3766-60512		

Table 8-1. Printer and Paper-Handling Components (continued)

Ref	Description/Product Number	Part Number	Exchange/Service Number	QTY
not shown	Stapler Cartridges (3-pack)/C3772A			
not shown	Power Box (includes clip)	C4781-60500		
not shown	Jumper Cable, short	C4781-60501		
not shown	Jumper Cable, long	C4781-60502		

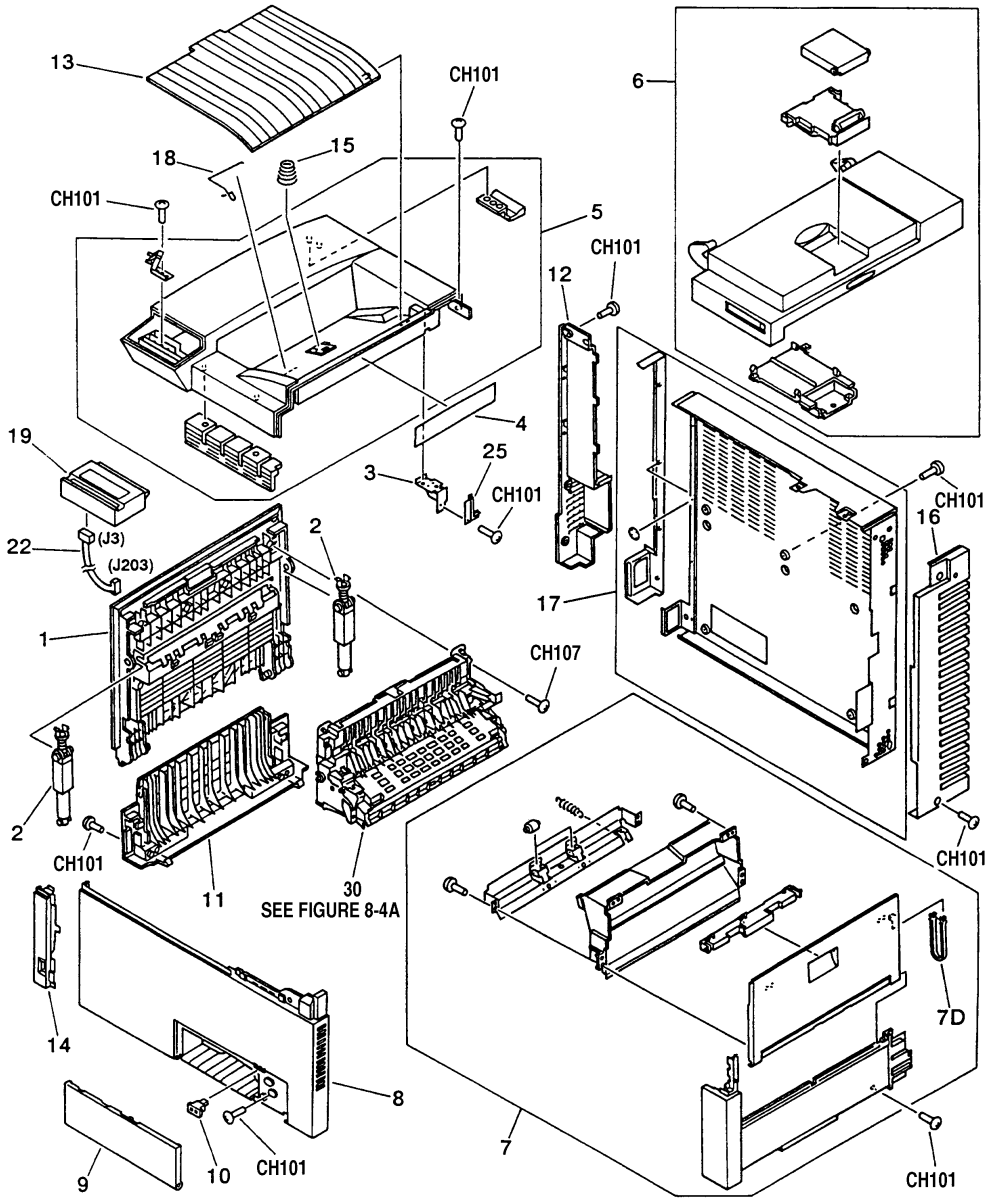

Figure 8-2 Printer Covers and Doors

Table 8-2. Printer Covers and Doors

Ref	Description	Part Number	QTY
01	Left Access Door	RB1-6667-000CN	1
02	Left Access Door Struts	RF5-1440-000CN	2
03	Hinge Plate	RB1-6507-000CN	1
04	Label, Operation (Special Order)	RS5-8596-000CN	1
05	Cover Assembly	RG5-1870-000CN	1
07	Right Cover Assembly	RG5-1915-040CN	1
07D	Open / Close Stopper	RB1-6484-000CN	1
08	Front Cover	RB1-6494-000CN	1
09	Front Door	RB1-6495-000CN	1
10	Front Door Latch	XZ9-0379-000CN	1
11	Cover, Left Lower (Special Order)	RB1-6480-000CN	1
12	AC Access Cover	RB1-6489-000CN	1
13	Left Output Bin (Special Order)	RB1-6490-000CN	1
14	Cover, Switch (Special Order)	RB1-6492-000CN	1
15	Spring, Compression (Special Order)	RB1-6493-000CN	1
16	Right, Lower Cover (Rear Plastic on Sheet Metal)	RB1-6498-000CN	1
17	Rear Cover	RF5-1402-000CN	1
18	Spring, Torsion (Special Order)	RB1-6509-000CN	1
19	Front Panel (Control Panel Display)	RG5-4384-000CN	1
22	Cable Assembly	RG5-4726-000CN	1
25	Plate Guard	RB1-6522-000CN	1
30	Diverter Assembly	RG9-1150-000CN	1
CH101	Screw, w/ washer, M3X8	XA9-0872-000CN	6

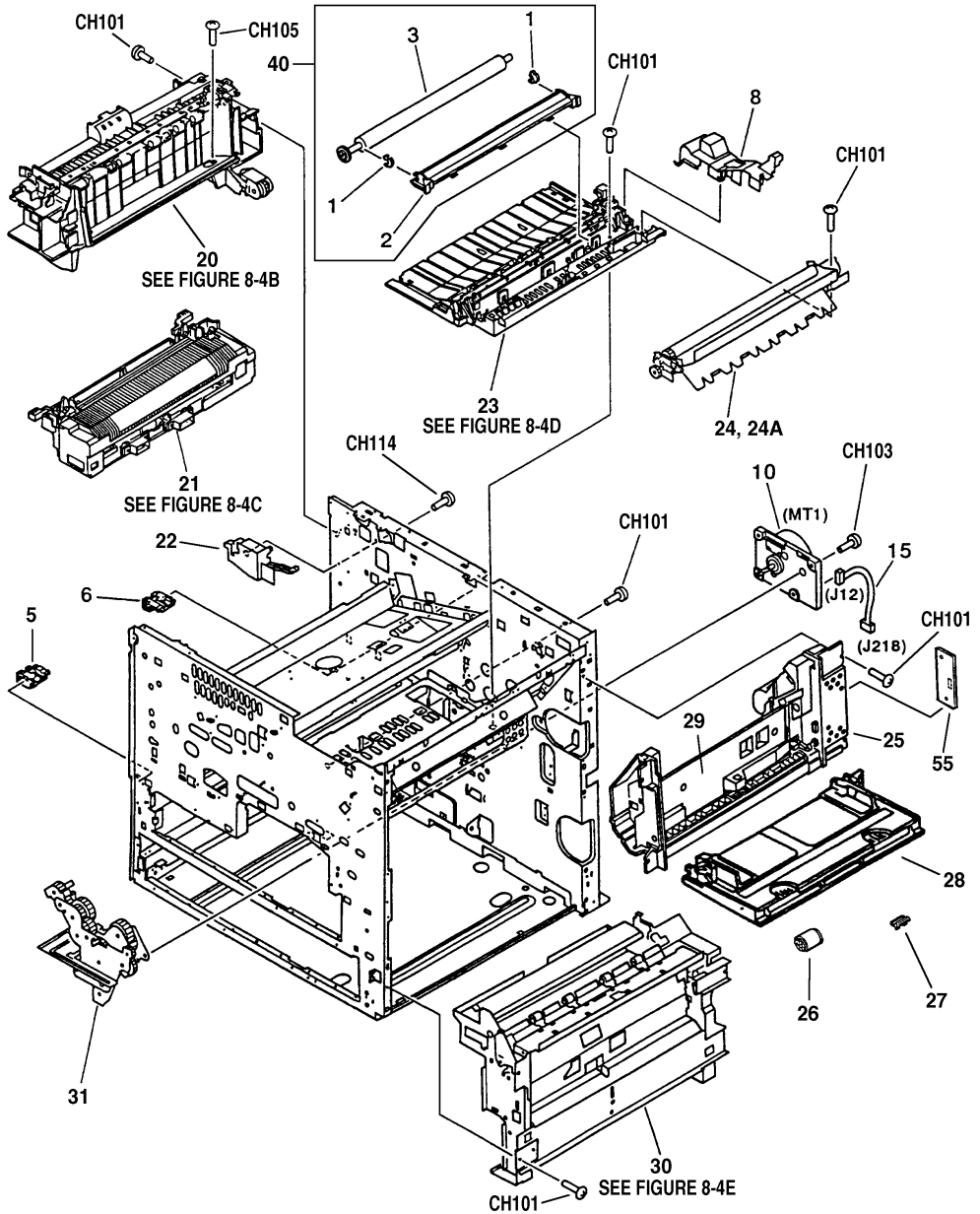
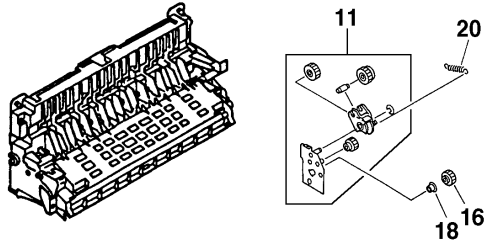

Figure 8-3 Printer Internal Components (1 of 4)

Table 8-3. Printer Internal Components (1 of 4)

Ref	Description	Part Number	QTY
01	Transfer Guide Bushing	RB1-6441-000CN	2
02	Transfer Guide	RF5-1394-000CN	1
03	Transfer Roller	RF5-1412-000CN	1
05	Damper Holder (Front)	RB1-6461-000CN	1
06	Damper Holder (Rear)	RB1-6462-000CN	1
08	Clutch Cover	RB1-6468-000CN	1
10	Main Motor	RH7-1260-000CN	1
15	Main Motor Cable	RG5-1919-000CN	1
20	Face-Down Delivery Assembly	RG5-1874-000CN	1
21A	Fusing Assembly 100-120V	RG5-4447-000CN	1
21B	Fusing Assembly 220-240V	RG5-4448-000CN	1
21C	Fusing Assembly 100-120V, Exchange	C3166-69001	
21D	Fusing Assembly 220-240V, Exchange	C3166-69013	
22	Face-Up Solenoid Assembly	RG5-1875-000CN	1
23	Feeder Assembly	RG5-1834-000CN	1
24	Registration Assembly	RG5-1833-040CN	1
24A	Electromagnetic Clutch	RH7-5119-000CN	1
25	Tray 1 Pickup Assembly	RG5-1880-100CN	1
26	Tray 1 Feed Roller	RB1-6730-000CN	1
27	Tray 1 Separation Pad	RF5-1455-000CN	1
28	Tray 1 Door	RG5-1883-000CN	1
29	Tray 1 Internal Cover (Shield)	RB1-6749-000CN	1
30	Paper Input Unit (PIU)	RG5-1852-160CN	1
30A	Paper Input Unit (PIU), Exchange	C3166-69011	
31	Main Gear Assembly	RG5-1847-000CN	1
40	Transfer Roller Assembly	RG5-1887-000CN	1
55	Tray 1 PCA	RG5-1884-000CN	1
CH101	Screw, with Washer, M3X8	XA9-0872-000CN	10
CH103	Screw, M4X8	XB6-7400-807CN	4
CH105	Screw, w/washer, M3X20	XA9-0817-000CN	2
CH114	Screw, tapping, M4X8	XA9-0605-000CN	2

A



B

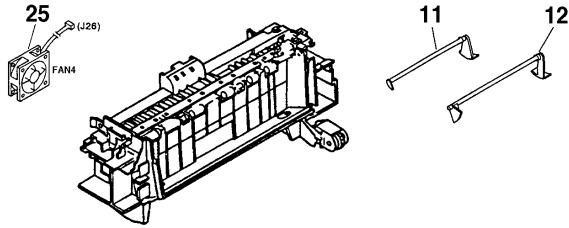

C

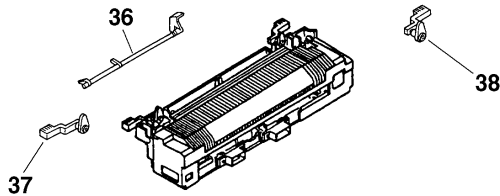

D

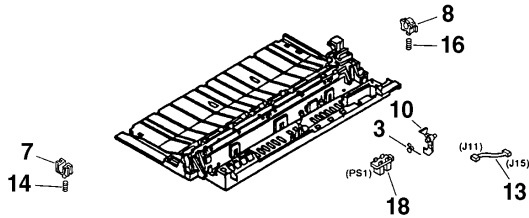

E

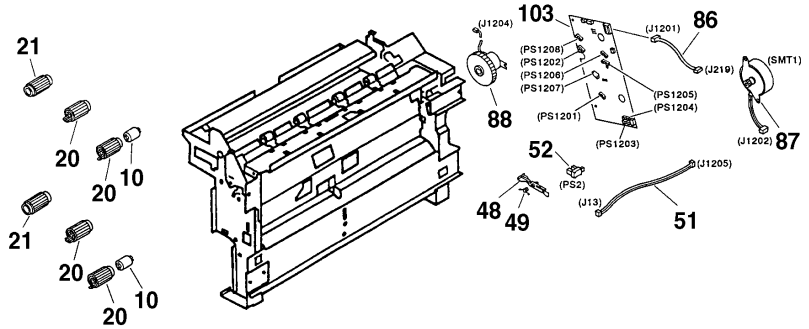

Figure 8-4 Printer Internal Components (2 of 4) (continued)

Table 8-4. Printer Internal Components (2 of 4)

Fig	Ref	Description	Part	QTY
8-04	A	Diverter Assembly	RG9-1150-000CN	
8-04A	11	Diverter Drive Assembly	RF5-1441-000CN	1
8-04A	16	20T Gear	RS5-0758-000CN	1
8-04A	18	Conductive Bushing	RS5-1101-000CN	1
8-04A	20	Tension Spring	RS5-2490-000CN	1
8-04B	11	Paper Sensing Lever	RB1-6692-000CN	1
8-04B	12	Paper Height Lever	RB1-6693-000CN	1
8-04B	25	Fan 4	RH7-1289-000CN	1
8-04	C	Fuser Assembly 110V, Exchange	C3166-69001	
8-04	C	Fusing Assembly 220-240V, Exchange	C3166-69013	
8-04C	36	Fuser Flag	RB1-6614-000CN	1
8-04C	37	Fuser Lock Lever Right	RB1-6615-000CN	1
8-04C	38	Fuser Lock Lever Left	RB1-6616-000CN	1
8-04	D	Feeder Assembly	RG5-1834-000CN	
8-04D	03	Sensor Arm Spring	RB1-6409-000CN	1
8-04D	07	Block, Shaft Holding, Front	RB1-6414-000CN	1
8-04D	08	Block, Shaft Holding, Rear	RB1-6415-000CN	1
8-04D	10	Sensor Arm PS1	RB1-6417-000CN	1
8-04D	13	Sensor Cable	RG5-1843-000CN	1
8-04D	14	Compression Spring, Front	RS5-2463-000CN	1
8-04D	16	Compression Spring, Rear	RS5-2466-000CN	1
8-04D	18	Photo Interrupter	WG8-0291-000CN	1
8-04	E	Paper Input Unit (PIU)	C3166-69011	
8-04E	10	Torque Limiter	RB1-6588-000CN	2
8-04E	103	PIU PCA	RG5-1860-000CN	1
8-04E	20	Feed / Separation Rollers	RF5-1426-000CN	4
8-04E	21	Pickup Roller	RF5-1427-000CN	2
8-04E	48	Sensor Arm PS2	RB1-6557-000CN	1
8-04E	49	Sensor Arm Spring	RB1-6558-000CN	1
8-04E	51	Sensor Cable	RG5-1859-000CN	1
8-04E	52	Photo Interrupter	WG8-0291-000CN	1
8-04E	86	Paper Pickup Cable	RG5-1861-000CN	1

Table 8-4. Printer Internal Components (2 of 4) (continued)

Fig	Ref	Description	Part	QTY
8-04E	87	Pickup Motor	RH7-1262-000CN	1
8-04E	88	Electromagnetic Clutch (Paper Feed)	RH7-5120-000CN	1

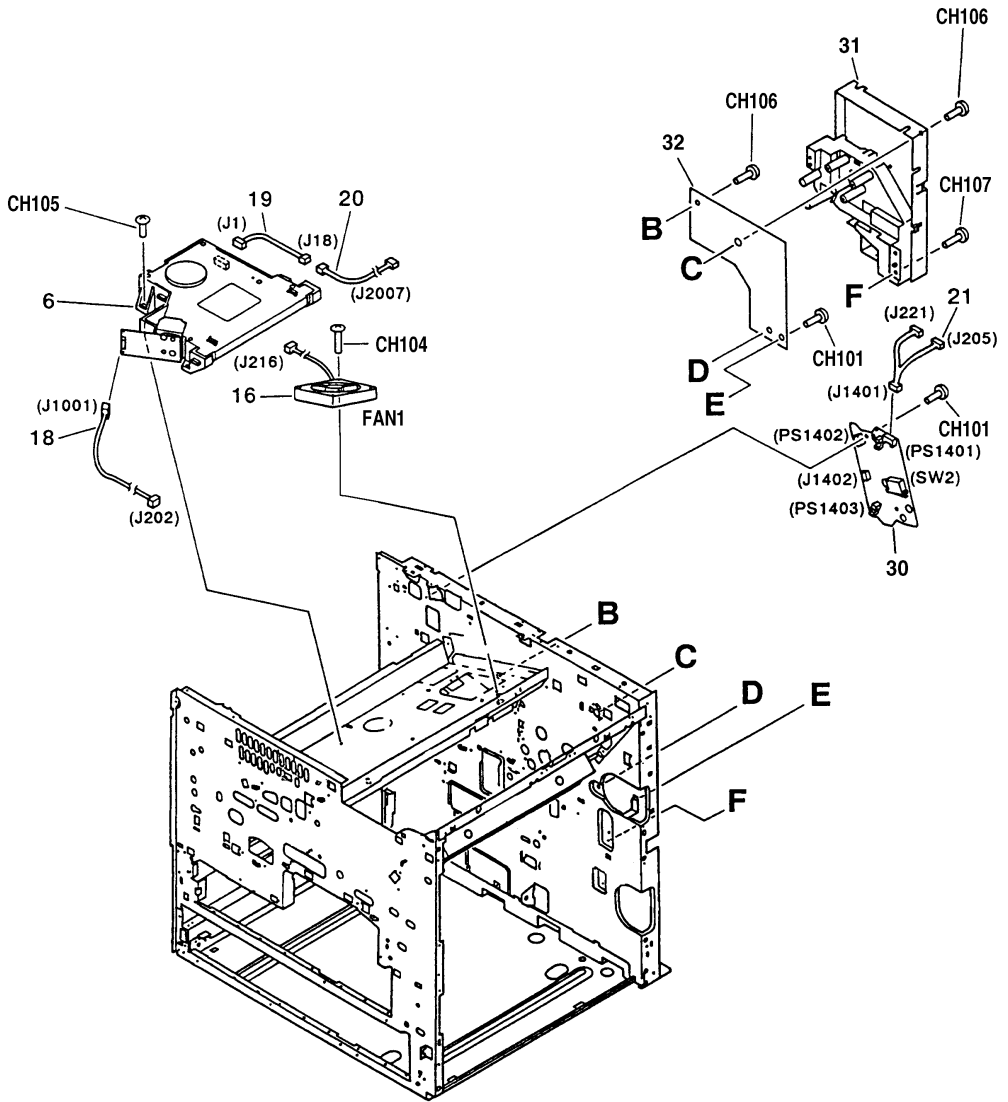

Figure 8-5 Printer Internal Components (3 of 4)

Table 8-5. Printer Internal Components (3 of 4)

Ref	Description	Part Number	QTY
06	Laser / Scanner Assembly	RG5-1895-000CN	1
06A	Laser / Scanner Assembly, Exchange	C3166-69006	
16	Fan 1	RH7-1266-000CN	1
18	Cable Assembly	RG5-1924-000CN	1
19	Scanner Motor Cable	RG5-1925-000CN	1
20	BD Cable	RG5-1926-000CN	1
21	ILS Cable	RG5-1927- 000CN	1
30	Switch / Sensor PCA	RG5-1846-000CN	1
31	High Voltage Power Supply	RG5-1888-000CN	1
31A	High Voltage Power Supply, Exchange	C3166-69005	
32	DC Controller PCA	RG5-1844-050CN	1
32A	DC Controller PCA, Exchange	C3166-69010	
CH101	Screw, with Washer, M3X8	XA9-0872-000CN	8
CH104	Screw, CT, M3X3	XB5-7303-007CN	2
CH105	Screw, w/washer, M3X20	XA9-0817-000CN	4
CH106	Screw, tapping, truss head, M3X8	XB4-7300-809CN	3
CH107	Screw, tapping, pan head, M4X10	XB4-7401-009CN	3
*	Thermal Control PCA	C3125-60002	1
*	Thermal Control PCA Cable	C3125-00001	1

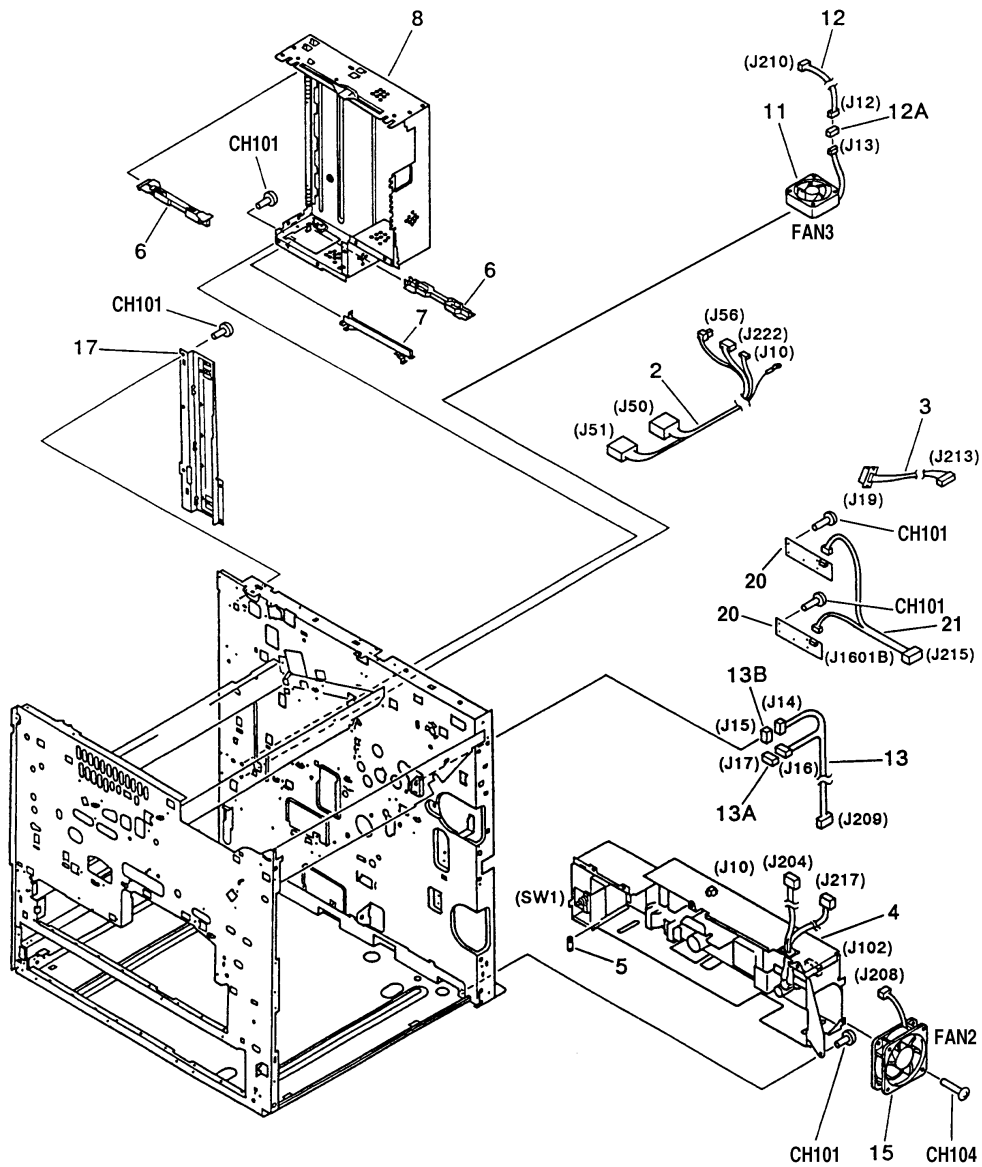

Figure 8-6 Printer Internal Components (4 of 4)

Table 8-6. Printer Internal Components (4 of 4)

Ref	Description	Part Number	QTY
02	Fuser Cable 1	RG5-1849-000CN	1
03	Fuser Cable 2	RG5-1850-000CN	1
04A	Low Voltage Power Supply, 110-120V	RG5-1876-000CN	1
04B	Low Voltage Power Supply, Universal	RG5-1878-000CN	1
04C	Low Voltage Power Supply, 110-120V, Exchange	C3166-69007	1
04D	Low Voltage Power Supply, Universal, Exchange	C3166-69008	1
05	Fuse, LVPS, 110-120V	VD5-0056-301CN	1
05A	Fuse, LVPS, Universal	VD7-0646-301CN	1
06	Guide, PCA	RB1-6771-000CN	1
07	Guide, Slide	RB1-6775-000CN	1
08	Formatter Shield	RF5-1466-000CN	1
11	Fan 3	RH7-1271-000CN	1
12	Fan 3 Cable	RG5-1921-000CN	1
13	Registration Cable	RG5-1928-000CN	1
13A	Connector, 7P	VS1-5057-007CN	1
13B	Connector, 3P	RG5-1928-000CN	1
15	Fan 2	RH7-1266-000CN	1
17	Plate Shield	RF5-1464-000CN	1
20	Paper Size Sensing PCA, Trays 2 and 3	RG5-1845-000CN	2
21	Cassette Size Sensor Cable	RG5-1920-000CN	1
CH101	Screw, with Washer	XA9-0872-000CN	16
CH104	Screw, CT, M3X3	XB5-7303-007CN	4

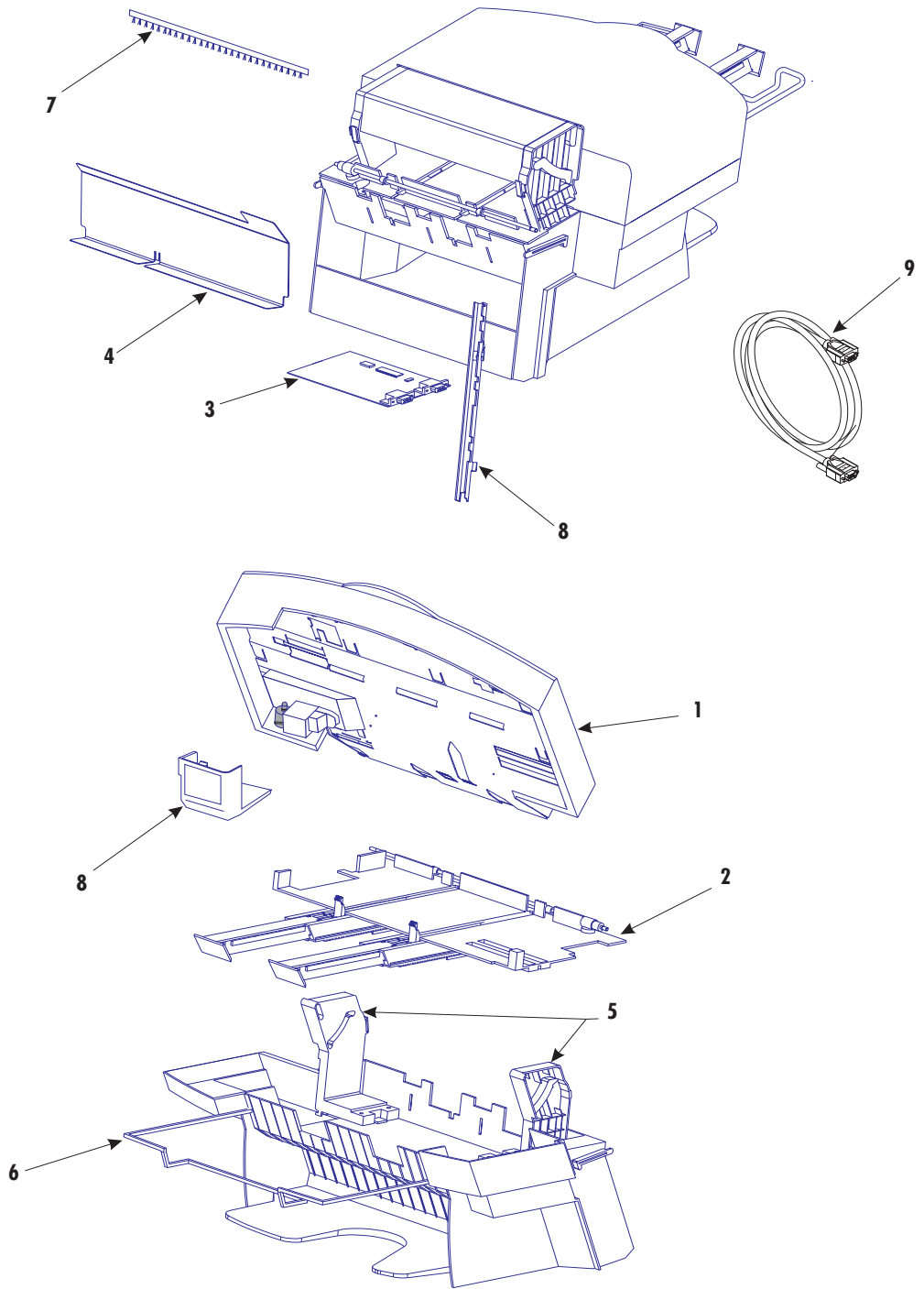

Figure 8-7 Stapler Internal Components

Table 8-7. Stapler Internal Components

Ref	Description	Part Number	QTY
	Stapler Assembly	C4787-60500	1
	Exchange Stapler	C4787-69500	1
1	Top Cover Assembly	C3766-60501	1
2	Stapling Bed Assembly	C3766-60503	1
3	Stapler Control PCA	C4787-60501	1
4	Back Plate	C3766-60505	1
5	Hinges, Set of	C3766-60506	1
6	Wire Frame	C3766-60507	1
7	Brushes	C3766-60508	1
not shown	Stapler Packaging	C3766-60509	1
8	Kit: Plastic staple cover; scan bar (shown) bin full sensor, actuator, and flag (not shown)	C3766-60510	1
not shown	Kit: T10 Torx screws (10)	C3766-60511	1
9	C-link Cable (97 cm)	C3766-60512	1
not shown	Mailbox with Stapler Packaging	C3766-60516	1

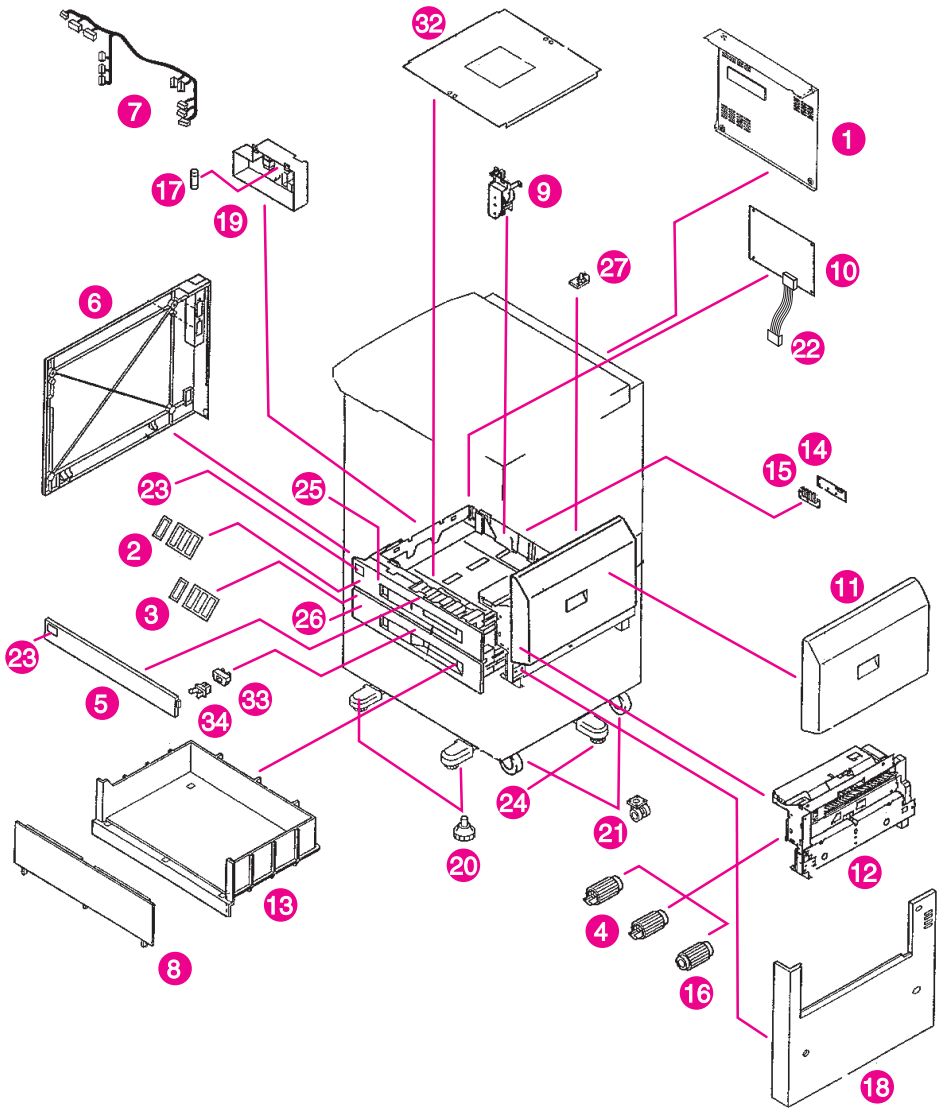

Figure 8-8 2 x 500-sheet Input Tray Internal Components

Table 8-8. 2 x 500-sheet Input Tray Internal Components

Reference	Description	Part Number	QTY
1	Back Cover	RB2-3675-000CN	1
2	Cassette Size Labels	RS5-8611-000CN	1
3	Cassette Size Plate	RB1-6894-000CN	1
4	Feed & Separation Rollers	RF5-1834-000CN	4
5	Front Top Cover	RF5-2762-000CN	1
6	Left Cover	RF5-2764-000CN	1
7	Main Cable	RG5-4440-000CN	1
8	Front Door (Cover Storage Tray)	RB2-3668-000CN	1
9	Paper Deck Drive Assembly	RG5-4416-000CN	1
10	2 x 500-sheet Input Tray Controller PCA	RG5-4442-000CN	1
11	Paper Feed Assembly (Vertical Transfer Unit)	RG5-4403-000CN	1
12	Paper Pickup Assembly	RG5-4410-000CN	1
13	Storage Paper Tray	RB2-3669-000CN	1
14	Cassette-Size Sensing PCA	RG5-1845-000CN	1
15	Holder Size PCA	RB2-3667-000CN	1
16	Pickup Roller	RF5-2708-000CN	1
17	Power Supply Fuse	VD7-1893-151CN	1
18	Right Cover	RB2-3666-000CN	1
19	Universal Power Supply	RG5-4021-000CN	1
20	Outrigger	RG5-3852-000CN	1
21	Caster	XZ9-0442-000CN	1
22	Power Supply Cable (PSU)	RG5-3909-000CN	1
23	Front LED PCA	RG5-4441-000CN	1
24	Adjustable Foot Tip	RG5-3863-000CN	1
25	Tray 4 Assembly	RG5-4420-000CN	1
26	Tray 5 Assembly	RG5-4421-000CN	1
27	Locating Pin, metallic (Positioning)	RF5-2556-000CN	1
not shown	Power Box (Includes bracket clip)	C4781-60500	1
not shown	Jumper Cable Short	C4781-60501	1
not shown	Jumper Cable Long	C4781-60502	1
32	Top Cover (Includes label)	RF5-2766-000CN	1
33	Spacer, latch	RB2-3705-000CN	1

Table 8-8. 2 x 500-sheet Input Tray Internal Components (continued)

34	Latch	XZ9-0379-000CN	1
----	-------	----------------	---

Note

All screws are included in the Screws Kit, and all shipping locks are included in the Shipping Locks Kit.

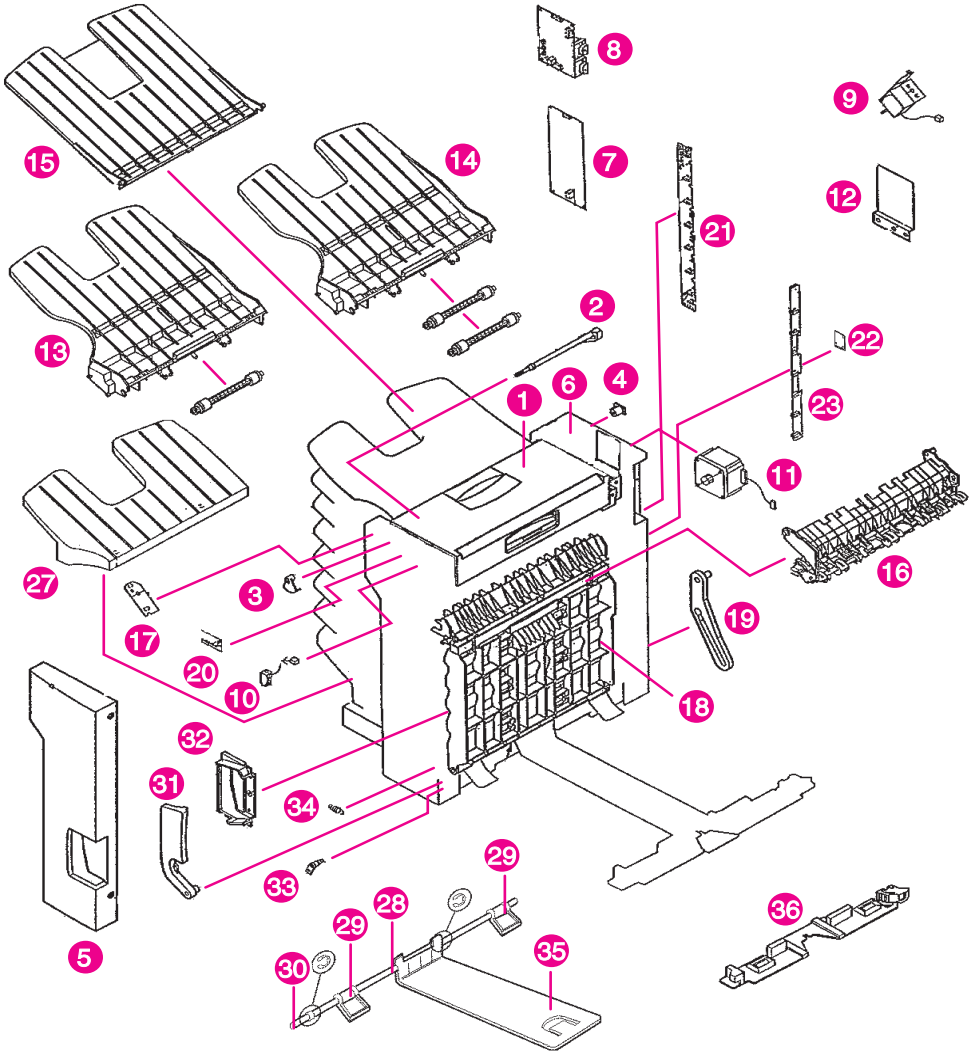

Figure 8-9 7-bin Tabletop Mailbox Internal Components

Table 8-9. 7-bin Tabletop Mailbox Internal Components

Reference	Description	Part Number	QTY
1	Top Cover Assembly (Upper Guide)	RG1-3838-000CN	1
2	Bin Full Sensor	RA2-2484-000CN	1
3	Flag, Sensor	RA2-2485-000CN	1
4	Bushing	RA2-2505-000CN	1
5	Front Cover	RF1-4004-000CN	1
6	Back Cover	RA2-2455-000CN	1
7	Power Supply	RH3-2205-000CN	1
8	7-bin Tabletop Mailbox Controller PCA Assembly	RG1-3853-000CN	1
9	Solenoid Reversing Mechanism	RH7-5223-000CN	1
10	Solenoid Flipper	RH7-5225-000CN	1
11	Reversing Mechanism Motor	RF7-1395-000CN	1
12	Plate (Motor Cover)	RA2-2541-000CN	1
13	Odd Face-down Bin Assembly	RG1-3836-000CN	1
14	Even Face-down Bin Assembly	RG1-3837-000CN	1
15	Reversing Tray (Face-up)	RA2-2487-000CN	1
16	Diverter Assembly (Flipper)	RG1-3844-000CN	1
17	Face-up Bin Full & Sensor PCA	RG1-3816-000CN	1
18	Right Cover Assembly	RG1-3840-000CN	1
19	Plate, Stopper	RA2-2527-000CN	1
20	LED PCA	RG1-3817-000CN	1
21	Empty Bin Sensor PCA	RG1-3815-000CN	1
22	Support Plate	RA2-2500-000CN	1
23	Full Bin & Interlock sensor PCA	RG1-3814-000CN	1
not shown	C-link Cable (80 cm)	C4783-70000	1
25	7-bin Tabletop Mailbox, whole unit	R95-3007-000CN	1
not shown	7-bin Tabletop Mailbox, Stand Assembly	C4784-60500	1
27	Bottom Bin (Tray)	RA2-2408-000CN	1
28	Shaft	RA2-3842-000CN	1
29	Latch	RA2-3842-000CN	2
30	Bushing	FS1-1449-000CN	1
31	Handle Latch	RA2-2512-000CN	1

Table 8-9. 7-bin Tabletop Mailbox Internal Components (continued)

32	Cover Latch	RA2-2531-000CN	1
33	Pin Positioning Bushing	RA2-2439-000CN	1
34	Spring Tension	RA2-2513-000CN	1
35	Rail	RA2-3842-000CN	1
36	Plate, Latch	RF1-4005-000CN	1

Note

All screws are included in the Screws Kit, and all shipping locks are included in the Shipping Locks Kit.

Alphabetical Parts List

Table 8-10. Alphabetical Parts List

Description	Part Number	Table No. & Page
2 x 500-sheet Input Tray/C4780A		table 8-1 on page 446
2 x 500-sheet Input Tray Controller PCA	RG5-4442-000CN	table 8-8 on page 462
2000-sheet Tray (Tray 4)/C4781A or 2 x 500-sheet Input Tray/C4780A		table 8-1 on page 446
20T Gear	RS5-0758-000CN	table 8-4 on page 453
7-bin Tabletop Mailbox Controller PCA Assembly	RG1-3853-000CN	table 8-9 on page 465
7-bin Tabletop Mailbox Stand/C4784A	C4784-60500	table 8-1 on page 446
7-bin Tabletop Mailbox, Stand Assembly	C4784-60500	table 8-9 on page 465
7-bin Tabletop Mailbox, whole unit	R95-3007-000CN	table 8-9 on page 465
7-bin Tabletop Mailbox/C4783A		table 8-1 on page 446
8-bin Multibin Mailbox/C4785A or 5-bin Mailbox for Stapler/C4787A		table 8-1 on page 446
AC Access Cover	RB1-6489-000CN	table 8-2 on page 449
Adjustable Foot Tip	RG5-3863-000CN	table 8-8 on page 462
Back Cover, 7-bin Tabletop Mailbox	RA2-2455-000CN	table 8-9 on page 465
Back Cover, 2 x 500-sheet Input Tray	RB2-3675-000CN	table 8-8 on page 462
Back Plate	C3766-60505	table 8-7 on page 460
BD Cable	RG5-1926-000CN	table 8-5 on page 456
Bin Full Sensor	RA2-2484-000CN	table 8-9 on page 465
Block, Shaft Holding, Front	RB1-6414-000CN	table 8-4 on page 453
Block, Shaft Holding, Rear	RB1-6415-000CN	table 8-4 on page 453
Bottom Bin (Tray)	RA2-2408-000CN	table 8-9 on page 465
Brushes	C3766-60508	table 8-7 on page 460
Bushing, Cover, 7-bin Tabletop Mailbox	RA2-2505-000CN	table 8-9 on page 465
Bushing, Roller, 7-bin Tabletop Mailbox	FS1-1449-000CN	table 8-9 on page 465
Cable Assembly, Control Panel	RG5-4726-000CN	table 8-2 on page 449
Cable Assembly, Laser/Scanner	RG5-1924-000CN	table 8-5 on page 456
Cassette Size Labels	RS5-8611-000CN	table 8-8 on page 462
Cassette Size Plate	RB1-6894-000CN	table 8-8 on page 462

Table 8-10. Alphabetical Parts List (continued)

Cassette Size Sensor Cable	RG5-1920-000CN	table 8-6 on page 458
Cassette-Size Sensing PCA	RG5-1845-000CN	table 8-8 on page 462
Caster	XZ9-0442-000CN	table 8-8 on page 462
C-link Cable (80 cm)	C4783-70000	table 8-9 on page 465
C-link Cable (97 cm)	C3766-60512	table 8-7 on page 460
C-link Cable Assembly 178 cm (2000-sheet Input Tray to Multibin Mailbox)	C3764-70000	table 8-1 on page 446
C-link Cable Assembly 61 cm (Engine to 2000-sheet Input Tray)	C3763-70000	table 8-1 on page 446
C-link Cable Assembly 97 cm (Multibin Mailbox to Stapler)	C3766-60512	table 8-1 on page 446
Clutch Cover	RB1-6468-000CN	table 8-3 on page 451
Compression Spring, Front	RS5-2463-000CN	table 8-4 on page 453
Compression Spring, Rear	RS5-2466-000CN	table 8-4 on page 453
Conductive Bushing	RS5-1101-000CN	table 8-4 on page 453
Connector, 3P	RG5-1928-000CN	table 8-6 on page 458
Connector, 7P	VS1-5057-007CN	table 8-6 on page 458
Cover Assembly	RG5-1870-000CN	table 8-2 on page 449
Cover Latch	RA2-2531-000CN	table 8-9 on page 465
Cover, Left Lower (Special Order)	RB1-6480-000CN	table 8-2 on page 449
Cover, Switch (Special Order)	RB1-6492-000CN	table 8-2 on page 449
Damper Holder (Front)	RB1-6461-000CN	table 8-3 on page 451
Damper Holder (Rear)	RB1-6462-000CN	table 8-3 on page 451
DC Controller PCA	RG5-1844-050CN	table 8-5 on page 456
DC Controller PCA, Exchange	C3166-69010	table 8-5 on page 456
Diverter Assembly	RG9-1150-000CN	table 8-2 on page 449 table 8-4 on page 453
Diverter Assembly (Flipper)	RG1-3844-000CN	table 8-9 on page 465
Diverter Drive Assembly	RF5-1441-000CN	table 8-4 on page 453
Duplexer Roller 1	RB1-6822-000CN	table 8-1 on page 446
Duplexer/C4782A	C4782-60501	table 8-1 on page 446
EIO Coverplate	5021-0349	table 8-1 on page 446
Electromagnetic Clutch	RH7-5119-000CN	table 8-3 on page 451
Electromagnetic Clutch (Paper Feed)	RH7-5120-000CN	table 8-4 on page 453
Empty Bin Sensor PCA	RG1-3815-000CN	table 8-9 on page 465

Table 8-10. Alphabetical Parts List (continued)

Envelope Feeder/C3765B		table 8-1 on page 446
Even Face-down Bin Assembly	RG1-3837-000CN	table 8-9 on page 465
Exchange Stapler	C4787-69500	table 8-7 on page 460
Face-up Solenoid Assembly	RG5-1875-000CN	table 8-3 on page 451
Face-Down Delivery Assembly	RG5-1874-000CN	table 8-3 on page 451
Face-up Bin Full & Sensor PCA	RG1-3816-000CN	table 8-9 on page 465
Fan 1	RH7-1266-000CN	table 8-5 on page 456
Fan 2	RH7-1266-000CN	table 8-6 on page 458
Fan 3	RH7-1271-000CN	table 8-6 on page 458
Fan 3 Cable	RG5-1921-000CN	table 8-6 on page 458
Fan 4	RH7-1289-000CN	table 8-4 on page 453
Feed & Separation Rollers, 2 x 500-sheet Input Tray	RF5-1834-000CN	table 8-8 on page 462
Feed & Separation Rollers, Paper Input Unit	RF5-1426-000CN	table 8-4 on page 453
Feeder Assembly	RG5-1834-000CN	table 8-3 on page 451 table 8-4 on page 453
Flag, Sensor	RA2-2485-000CN	table 8-9 on page 465
Formatter Assembly	C4186-67901	table 8-1 on page 446
Formatter Assembly, Exchange		table 8-1 on page 446
Formatter Shield	RF5-1466-000CN	table 8-6 on page 458
Front Cover, Printer Engine	RB1-6494-000CN	table 8-2 on page 449
Front Cover, 7-bin Tabletop Mailbox	RF1-4004-000CN	table 8-9 on page 465
Front Door	RB1-6495-000CN	table 8-2 on page 449
Front Door (Cover Storage Tray)	RB2-3668-000CN	table 8-8 on page 462
Front Door Latch	XZ9-0379-000CN	table 8-2 on page 449
Front LED PCA	RG5-4441-000CN	table 8-8 on page 462
Front Panel (Control Panel Display)	RG5-4384-000CN	table 8-2 on page 449
Front Top Cover	RF5-2762-000CN	table 8-8 on page 462
Full Bin & Interlock sensor PCA	RG1-3814-000CN	table 8-9 on page 465
Fuse, LVPS, 110-120V	VD5-0056-301CN	table 8-6 on page 458
Fuse, LVPS, Universal	VD7-0646-301CN	table 8-6 on page 458
Fuser Assembly 110V, Exchange	C3166-69001	table 8-4 on page 453
Fuser Cable 1	RG5-1849-000CN	table 8-6 on page 458
Fuser Cable 2	RG5-1850-000CN	table 8-6 on page 458
Fuser Flag	RB1-6614-000CN	table 8-4 on page 453

Table 8-10. Alphabetical Parts List (continued)

Fuser Lock Lever Left	RB1-6616-000CN	table 8-4 on page 453
Fuser Lock Lever Right	RB1-6615-000CN	table 8-4 on page 453
Fusing Assembly 100-120V	RG5-4447-000CN	table 8-3 on page 451
Fusing Assembly 100-120V, Exchange	C3166-69001	table 8-3 on page 451
Fusing Assembly 220-240V	RG5-4447-000CN	table 8-3 on page 451
Fusing Assembly 220-240V, Exchange	C3166-69013	table 8-3 on page 451 table 8-4 on page 453
Guide, PCA	RB1-6771-000CN	table 8-6 on page 458
Guide, Slide	RB1-6775-000CN	table 8-6 on page 458
Handle Latch	RA2-2512-000CN	table 8-9 on page 465
High Voltage Power Supply	RG5-1888-000CN	table 8-5 on page 456
High Voltage Power Supply, Exchange	C3166-69005	table 8-5 on page 456
Hinge Plate	RB1-6507-000CN	table 8-2 on page 449
Hinges, Set of	C3766-60506	table 8-7 on page 460
Holder Size PCA	RB2-3667-000CN	table 8-8 on page 462
ILS Cable	RG5-1927- 000CN	table 8-5 on page 456
Jumper Cable, Long	C4781-60502	table 8-8 on page 462
Jumper Cable, Short	C4781-60501	table 8-8 on page 462
Kit: Plastic staple cover; scan bar (shown) bin full sensor, actuator, and flag (not shown)	C3766-60510	table 8-7 on page 460
Kit: T10 Torx screws (10)	C3766-60511	table 8-7 on page 460
Label, Operation (Special Order)	RS5-8596-000CN	table 8-2 on page 449
Laser / Scanner Assembly	RG5-1895-000CN	table 8-5 on page 456
Laser / Scanner Assembly, Exchange	C3166-69006	table 8-5 on page 456
Latch, 7-bin Tabletop Mailbox	RA2-3842-000CN	table 8-9 on page 465
Latch, 2 x 500-sheet Input Tray	XZ9-0379-000CN	table 8-8 on page 462
LED PCA	RG1-3817-000CN	table 8-9 on page 465
Left Access Door	RB1-6667-000CN	table 8-2 on page 449
Left Access Door Struts	RF5-1440-000CN	table 8-2 on page 449
Left Cover	RF5-2764-000CN	table 8-8 on page 462
Left Output Bin	RB1-6491-000CN	table 8-1 on page 446
Left Output Bin (Special Order)	RB1-6490-000CN	table 8-2 on page 449
Locating Pin, metallic (Positioning)	RF5-2556-000CN	table 8-8 on page 462
Low Voltage Power Supply, 110-120V	RG5-1876-000CN	table 8-6 on page 458

Table 8-10. Alphabetical Parts List (continued)

Low Voltage Power Supply, 110-120V, Exchange	C3166-69007	table 8-6 on page 458
Low Voltage Power Supply, Universal	RG5-1878-000CN	table 8-6 on page 458
Low Voltage Power Supply, Universal, Exchange	C3166-69008	table 8-6 on page 458
Mailbox with Stapler Packaging	C3766-60516	table 8-7 on page 460
Main Cable	RG5-4440-000CN	table 8-8 on page 462
Main Gear Assembly	RG5-1847-000CN	table 8-3 on page 451
Main Motor	RH7-1260-000CN	table 8-3 on page 451
Main Motor Cable	RG5-1919-000CN	table 8-3 on page 451
Maintenance Kit, 100-120V/C3971B		table 8-1 on page 446
Maintenance Kit, 220-240V/C3972B		table 8-1 on page 446
Odd Face-down Bin Assembly	RG1-3836-000CN	table 8-9 on page 465
Open / Close Stopper	RB1-6484-000CN	table 8-2 on page 449
Outrigger	RG5-3852-000CN	table 8-8 on page 462
Packaging Kit, 2000-sheet Tray	C3763-60500	table 8-1 on page 446
Packaging Kit, duplexer	C3762-60500	table 8-1 on page 446
Packaging Kit, Envelope Feeder	C3765-60500	table 8-1 on page 446
Packaging Kit, Multibin Mailbox	C3764-60500	table 8-1 on page 446
Packaging Kit, Printer	C3166-67905	table 8-1 on page 446
Paper Deck Drive Assembly	RG5-4416-000CN	table 8-8 on page 462
Paper Feed Assembly (VTU)	RG5-4403-000CN	table 8-8 on page 462
Paper Height Lever	RB1-6693-000CN	table 8-4 on page 453
Paper Input Unit (PIU)	RG5-1852-160CN	table 8-3 on page 451
Paper Input Unit (PIU)	C3166-69011	table 8-4 on page 453
Paper Input Unit (PIU), Exchange	C3166-69011	table 8-3 on page 451
Paper Pickup Assembly	RG5-4410-000CN	table 8-8 on page 462
Paper Pickup Cable	RG5-1861-000CN	table 8-4 on page 453
Paper Sensing Lever	RB1-6692-000CN	table 8-4 on page 453
Paper Size Guide, Trays 2 and 3	RF5-1484-000CN	table 8-1 on page 446
Paper Size Guide Label, Trays 2 and 3	RS5-8605-000CN	table 8-1 on page 446
Paper Size Sensing PCA, Trays 2 and 3	RG5-1845-000CN	table 8-6 on page 458
Photo Interrupter	WG8-0291-000CN	table 8-4 on page 453
Pickup Motor	RH7-1262-000CN	table 8-4 on page 453
Pickup Roller, 2 x 500-sheet Input Tray	RF5-2708-000CN	table 8-8 on page 462

Table 8-10. Alphabetical Parts List (continued)

Pickup Roller, Paper Input Unit	RF5-1427-000CN	table 8-4 on page 453
Pin Positioning Bushing	RA2-2439-000CN	table 8-9 on page 465
PIU PCA	RG5-1860-000CN	table 8-4 on page 453
Plate (Motor Cover)	RA2-2541-000CN	table 8-9 on page 465
Plate Guard	RB1-6522-000CN	table 8-2 on page 449
Plate Shield	RF5-1464-000CN	table 8-6 on page 458
Plate, Latch	RF1-4005-000CN	table 8-9 on page 465
Plate, Stopper	RA2-2527-000CN	table 8-9 on page 465
Power Box (Includes bracket clip)	C4781-60500	table 8-8 on page 462
Power Supply	RH3-2205-000CN	table 8-9 on page 465
Power Supply Cable (PSU)	RG5-3909-000CN	table 8-8 on page 462
Power Supply Fuse	VD7-1893-151CN	table 8-8 on page 462
Rail	RA2-3842-000CN	table 8-9 on page 465
Rear Cover	RF5-1402-000CN	table 8-2 on page 449
Registration Assembly	RG5-1833-040CN	table 8-3 on page 451
Registration Cable	RG5-1928-000CN	table 8-6 on page 458
Reversing Mechanism Motor	RF7-1395-000CN	table 8-9 on page 465
Reversing Tray (Face-up)	RA2-2487-000CN	table 8-9 on page 465
Right Cover	RB2-3666-000CN	table 8-8 on page 462
Right Cover Assembly, Printer Engine	RG5-1915-040CN	table 8-2 on page 449
Right Cover Assembly, 7-bin Tabletop Mailbox	RG1-3840-000CN	table 8-9 on page 465
Right, Lower Cover (Rear Plastic on Sheet Metal)	RB1-6498-000CN	table 8-2 on page 449
Scanner Motor Cable	RG5-1925-000CN	table 8-5 on page 456
Screw, CT, M3X3	XB5-7303-007CN	table 8-5 on page 456 table 8-6 on page 458
Screw, M4X8	XB6-7400-807CN	table 8-3 on page 451
Screw, tapping, M4X8	XA9-0605-000CN	table 8-3 on page 451
Screw, tapping, pan head, M4X10	XB4-7401-009CN	table 8-5 on page 456
Screw, tapping, truss head, M3X8	XB4-7300-809CN	table 8-5 on page 456
Screw, with Washer, M3X8	XA9-0872-000CN	table 8-2 on page 449 table 8-3 on page 451 table 8-5 on page 456 table 8-6 on page 458
Screw, w/washer, M3X20	XA9-0817-000CN	table 8-3 on page 451 table 8-5 on page 456

Table 8-10. Alphabetical Parts List (continued)

Sensor Arm PS1	RB1-6417-000CN	table 8-4 on page 453
Sensor Arm PS2	RB1-6557-000CN	table 8-4 on page 453
Sensor Arm Spring, Feeder Assembly	RB1-6409-000CN	table 8-4 on page 453
Sensor Arm Spring, Paper Input Unit	RB1-6558-000CN	table 8-4 on page 453
Sensor Cable, Feeder Assembly	RG5-1843-000CN	table 8-4 on page 453
Sensor Cable, Paper Input Unit	RG5-1859-000CN	table 8-4 on page 453
Shaft	RA2-3842-000CN	table 8-9 on page 465
Solenoid Flipper	RH7-5225-000CN	table 8-9 on page 465
Solenoid Reversing Mechanism	RH7-5223-000CN	table 8-9 on page 465
Spacer, latch	RB2-3705-000CN	table 8-8 on page 462
Spring Tension	RA2-2513-000CN	table 8-9 on page 465
Spring, Compression (Special Order)	RB1-6493-000CN	table 8-2 on page 449
Spring, Torsion (Special Order)	RB1-6509-000CN	table 8-2 on page 449
Stapler Assembly	C4787-60500	table 8-7 on page 460 table 8-1 on page 446
Stapler Cartridges (3-pack)/C3772A		table 8-1 on page 446
Stapler Control PCA	C4787-60501	table 8-7 on page 460
Stapler Packaging	C3766-60509	table 8-7 on page 460
Stapling Bed Assembly	C3766-60503	table 8-7 on page 460
Storage Paper Tray	RB2-3669-000CN	table 8-8 on page 462
Support Plate	RA2-2500-000CN	table 8-9 on page 465
Switch / Sensor PCA	RG5-1846-000CN	table 8-5 on page 456
Tension Spring	RS5-2490-000CN	table 8-4 on page 453
Thermal Control PCA	C3125-60002	table 8-5 on page 456
Thermal Control PCA Cable	C3125-00001	table 8-5 on page 456
Toner Cartridge/C3909A		table 8-1 on page 446
Top Cover (Includes label)	RF5-2766-000CN	table 8-8 on page 462
Top Cover Assembly	C3766-60501	table 8-7 on page 460
Top Cover Assembly (Upper Guide)	RG1-3838-000CN	table 8-9 on page 465
Torque Limiter	RB1-6588-000CN	table 8-4 on page 453
Transfer Guide	RF5-1394-000CN	table 8-3 on page 451
Transfer Guide Bushing	RB1-6441-000CN	table 8-3 on page 451
Transfer Roller	RF5-1412-000CN	table 8-3 on page 451
Transfer Roller Assembly	RG5-1887-000CN	table 8-3 on page 451

Table 8-10. Alphabetical Parts List (continued)

Tray 1 Door	RG5-1883-000CN	table 8-3 on page 451
Tray 1 Feed Roller	RB1-6730-000CN	table 8-3 on page 451
Tray 1 Internal Cover (Shield)	RB1-6749-000CN	table 8-3 on page 451
Tray 1 PCA	RG5-1884-000CN	table 8-3 on page 451
Tray 1 Pickup Assembly	RG5-1880-100CN	table 8-3 on page 451
Tray 1 Separation Pad	RF5-1455-000CN	table 8-3 on page 451
Tray 2	RG5-3951-000CN	table 8-1 on page 446
Tray 3	RG5-3952-000CN	table 8-1 on page 446
Tray 4 Assembly	RG5-4420-000CN	table 8-8 on page 462
Tray 5 Assembly	RG5-4421-000CN	table 8-8 on page 462
Universal Power Supply	RG5-4021-000CN	table 8-8 on page 462
Wire Frame	C3766-60507	table 8-7 on page 460

Numerical Parts List

Table 8-11. Numerical Parts List

Part Number	Description	Table No. & Page
	Formatter Assembly, Exchange	table 8-1 on page 446
	Toner Cartridge/C3909A	table 8-1 on page 446
	Envelope Feeder/C3765B	table 8-1 on page 446
	2000-sheet Tray (Tray 4)/C4781A or 2 x 500-sheet Input Tray/C4780A	table 8-1 on page 446
	8-bin Multibin Mailbox/C4785A or 5-bin Mailbox for Stapler/C4787A	table 8-1 on page 446
	7-bin Tabletop Mailbox/C4783A	table 8-1 on page 446
	2 x 500-sheet Input Tray/C4780A	table 8-1 on page 446
	Maintenance Kit, 100-120V/C3971B	table 8-1 on page 446
	Maintenance Kit, 220-240V/C3972B	table 8-1 on page 446
	Stapler Cartridges (3-pack)/C3772A	table 8-1 on page 446
5021-0349	EIO Coverplate	table 8-1 on page 446
C3125-00001	Thermal Control PCA Cable	table 8-5 on page 456
C3125-60002	Thermal Control PCA	table 8-5 on page 456
C3166-67905	Packaging Kit, Printer	table 8-1 on page 446
C3166-69001	Fusing Assembly 100-120V, Exchange	table 8-3 on page 451
C3166-69001	Fuser Assembly 110V, Exchange	table 8-4 on page 453
C3166-69005	High Voltage Power Supply, Exchange	table 8-5 on page 456
C3166-69006	Laser / Scanner Assembly, Exchange	table 8-5 on page 456
C3166-69007	Low Voltage Power Supply, 110-120V, Exchange	table 8-6 on page 458
C3166-69008	Low Voltage Power Supply, Universal, Exchange	table 8-6 on page 458
C3166-69010	DC Controller PCA, Exchange	table 8-5 on page 456
C3166-69011	Paper Input Unit (PIU), Exchange	table 8-3 on page 451
C3166-69011	Paper Input Unit (PIU)	table 8-4 on page 453
C3166-69013	Fusing Assembly 220-240V, Exchange	table 8-3 on page 451 table 8-4 on page 453
C3762-60500	Packaging Kit, duplexer	table 8-1 on page 446
C3763-60500	Packaging Kit, 2000-sheet Tray	table 8-1 on page 446

Table 8-11. Numerical Parts List (continued)

C3763-70000	C-link Cable Assembly 61 cm (Engine to 2000-sheet Input Tray)	table 8-1 on page 446
C3764-60500	Packaging Kit, Multibin Mailbox	table 8-1 on page 446
C3764-70000	C-link Cable Assembly 178 cm (2000-sheet Input Tray to Multibin Mailbox)	table 8-1 on page 446
C3765-60500	Packaging Kit, Envelope Feeder	table 8-1 on page 446
C3766-60501	Top Cover Assembly	table 8-7 on page 460
C3766-60503	Stapling Bed Assembly	table 8-7 on page 460
C3766-60505	Back Plate	table 8-7 on page 460
C3766-60506	Hinges, Set of	table 8-7 on page 460
C3766-60507	Wire Frame	table 8-7 on page 460
C3766-60508	Brushes	table 8-7 on page 460
C3766-60509	Stapler Packaging	table 8-7 on page 460
C3766-60510	Kit: Plastic staple cover; scan bar (shown) bin full sensor, actuator, and flag (not shown)	table 8-7 on page 460
C3766-60511	Kit: T10 Torx screws (10)	table 8-7 on page 460
C3766-60512	C-link Cable Assembly 97 cm (Multibin Mailbox to Stapler)	table 8-1 on page 446
C3766-60512	C-link Cable (97 cm)	table 8-7 on page 460
C3766-60516	Mailbox with Stapler Packaging	table 8-7 on page 460
C4077-60102	3 Way Power Adapter	table 8-1 on page 446
C4186-67901	Formatter Assembly	table 8-1 on page 446
C4781-60500	Power Box (Includes bracket clip)	table 8-8 on page 462
C4781-60501	Jumper Cable Short	table 8-8 on page 462
C4781-60502	Jumper Cable Long	table 8-8 on page 462
C4782-60501	Duplexer/C4782A	table 8-1 on page 446
C4783-70000	C-link Cable (80 cm)	table 8-9 on page 465
C4784-60500	7-bin Tabletop Mailbox Stand/C4784A	table 8-1 on page 446
C4784-60500	7-bin Tabletop Mailbox, Stand Assembly	table 8-9 on page 465
C4787-60500	Stapler Assembly	table 8-1 on page 446 table 8-7 on page 460
C4787-60501	Stapler Control PCA	table 8-7 on page 460
C4787-69500	Exchange Stapler	table 8-7 on page 460
FS1-1449-000CN	Bushing, Roller, 7-bin Tabletop Mailbox	table 8-9 on page 465
R95-3007-000CN	7-bin Tabletop Mailbox, whole unit	table 8-9 on page 465
RA2-2408-000CN	Bottom Bin (Tray)	table 8-9 on page 465

Table 8-11. Numerical Parts List (continued)

RA2-2439-000CN	Pin Positioning Bushing	table 8-9 on page 465
RA2-2455-000CN	Back Cover, 7-bin Tabletop Mailbox	table 8-9 on page 465
RA2-2484-000CN	Bin Full Sensor	table 8-9 on page 465
RA2-2485-000CN	Flag, Sensor	table 8-9 on page 465
RA2-2487-000CN	Reversing Tray (Face-up)	table 8-9 on page 465
RA2-2500-000CN	Support Plate	table 8-9 on page 465
RA2-2505-000CN	Bushing, Cover, 7-bin Tabletop Mailbox	table 8-9 on page 465
RA2-2512-000CN	Handle Latch	table 8-9 on page 465
RA2-2513-000CN	Spring Tension	table 8-9 on page 465
RA2-2527-000CN	Plate, Stopper	table 8-9 on page 465
RA2-2531-000CN	Cover Latch	table 8-9 on page 465
RA2-2541-000CN	Plate (Motor Cover)	table 8-9 on page 465
RA2-3842-000CN	Shaft	table 8-9 on page 465
RA2-3842-000CN	Latch, 7-bin Tabletop Mailbox	table 8-9 on page 465
RA2-3842-000CN	Rail	table 8-9 on page 465
RB1-6409-000CN	Sensor Arm Spring, Feeder Assembly	table 8-4 on page 453
RB1-6414-000CN	Block, Shaft Holding, Front	table 8-4 on page 453
RB1-6415-000CN	Block, Shaft Holding, Rear	table 8-4 on page 453
RB1-6417-000CN	Sensor Arm PS1	table 8-4 on page 453
RB1-6441-000CN	Transfer Guide Bushing	table 8-3 on page 451
RB1-6461-000CN	Damper Holder (Front)	table 8-3 on page 451
RB1-6462-000CN	Damper Holder (Rear)	table 8-3 on page 451
RB1-6468-000CN	Clutch Cover	table 8-3 on page 451
RB1-6480-000CN	Cover, Left Lower (Special Order)	table 8-2 on page 449
RB1-6484-000CN	Open / Close Stopper	table 8-2 on page 449
RB1-6489-000CN	AC Access Cover	table 8-2 on page 449
RB1-6490-000CN	Left Output Bin (Special Order)	table 8-2 on page 449
RB1-6491-000CN	Left Output Bin	table 8-1 on page 446
RB1-6492-000CN	Cover, Switch (Special Order)	table 8-2 on page 449
RB1-6493-000CN	Spring, Compression (Special Order)	table 8-2 on page 449
RB1-6494-000CN	Front Cover, Printer Engine	table 8-2 on page 449
RB1-6495-000CN	Front Door	table 8-2 on page 449
RB1-6498-000CN	Right, Lower Cover (Rear Plastic on Sheet Metal)	table 8-2 on page 449

Table 8-11. Numerical Parts List (continued)

RB1-6507-000CN	Hinge Plate	table 8-2 on page 449
RB1-6509-000CN	Spring, Torsion (Special Order)	table 8-2 on page 449
RB1-6522-000CN	Plate Guard	table 8-2 on page 449
RB1-6557-000CN	Sensor Arm PS2	table 8-4 on page 453
RB1-6558-000CN	Sensor Arm Spring, Paper Input Unit	table 8-4 on page 453
RB1-6588-000CN	Torque Limiter	table 8-4 on page 453
RB1-6614-000CN	Fuser Flag	table 8-4 on page 453
RB1-6615-000CN	Fuser Lock Lever Right	table 8-4 on page 453
RB1-6616-000CN	Fuser Lock Lever Left	table 8-4 on page 453
RB1-6667-000CN	Left Access Door	table 8-2 on page 449
RB1-6692-000CN	Paper Sensing Lever	table 8-4 on page 453
RB1-6693-000CN	Paper Height Lever	table 8-4 on page 453
RB1-6730-000CN	Tray 1 Feed Roller	table 8-3 on page 451
RB1-6749-000CN	Tray 1 Internal Cover (Shield)	table 8-3 on page 451
RB1-6771-000CN	Guide, PCA	table 8-6 on page 458
RB1-6775-000CN	Guide, Slide	table 8-6 on page 458
RB1-6822-000CN	Duplexer Roller 1	table 8-1 on page 446
RB1-6894-000CN	Cassette Size Plate	table 8-8 on page 462
RB2-3666-000CN	Right Cover	table 8-8 on page 462
RB2-3667-000CN	Holder Size PCA	table 8-8 on page 462
RB2-3668-000CN	Front Door (Cover Storage Tray)	table 8-8 on page 462
RB2-3669-000CN	Storage Paper Tray	table 8-8 on page 462
RB2-3675-000CN	Back Cover, 2 x 500-sheet Input Tray	table 8-8 on page 462
RB2-3705-000CN	Spacer, latch	table 8-8 on page 462
RF1-4004-000CN	Front Cover, 7-bin Tabletop Mailbox	table 8-9 on page 465
RF1-4005-000CN	Plate, Latch	table 8-9 on page 465
RF5-1394-000CN	Transfer Guide	table 8-3 on page 451
RF5-1402-000CN	Rear Cover	table 8-2 on page 449
RF5-1412-000CN	Transfer Roller	table 8-3 on page 451
RF5-1426-000CN	Feed & Separation Rollers, Paper Input Unit	table 8-4 on page 453
RF5-1427-000CN	Pickup Roller, Paper Input Unit	table 8-4 on page 453
RF5-1440-000CN	Left Access Door Struts	table 8-2 on page 449
RF5-1441-000CN	Diverter Drive Assembly	table 8-4 on page 453
RF5-1455-000CN	Tray 1 Separation Pad	table 8-3 on page 451

Table 8-11. Numerical Parts List (continued)

RF5-1464-000CN	Plate Shield	table 8-6 on page 458
RF5-1466-000CN	Formatter Shield	table 8-6 on page 458
RF5-1484-000CN	Paper Size Guide (Trays 2 and 3)	table 8-1 on page 446
RF5-1834-000CN	Feed & Separation Rollers, 2 x 500-sheet Input Tray	table 8-8 on page 462
RF5-2556-000CN	Locating Pin, metallic (Positioning)	table 8-8 on page 462
RF5-2708-000CN	Pickup Roller, 2 x 500-sheet Input Tray	table 8-8 on page 462
RF5-2762-000CN	Front Top Cover	table 8-8 on page 462
RF5-2764-000CN	Left Cover	table 8-8 on page 462
RF5-2766-000CN	Top Cover (Includes label)	table 8-8 on page 462
RF7-1395-000CN	Reversing Mechanism Motor	table 8-9 on page 465
RG1-3814-000CN	Full Bin & Interlock sensor PCA	table 8-9 on page 465
RG1-3815-000CN	Empty Bin Sensor PCA	table 8-9 on page 465
RG1-3816-000CN	Face-up Bin Full & Sensor PCA	table 8-9 on page 465
RG1-3817-000CN	LED PCA	table 8-9 on page 465
RG1-3836-000CN	Odd Face-down Bin Assembly	table 8-9 on page 465
RG1-3837-000CN	Even Face-down Bin Assembly	table 8-9 on page 465
RG1-3838-000CN	Top Cover Assembly (Upper Guide)	table 8-9 on page 465
RG1-3840-000CN	Right Cover Assembly, 7-bin Tabletop Mailbox	table 8-9 on page 465
RG1-3844-000CN	Diverter Assembly (Flipper)	table 8-9 on page 465
RG1-3853-000CN	7-bin Tabletop Mailbox Controller PCA Assembly	table 8-9 on page 465
RG5-1833-040CN	Registration Assembly	table 8-3 on page 451
RG5-1834-000CN	Feeder Assembly	table 8-3 on page 451 table 8-4 on page 453
RG5-1843-000CN	Sensor Cable, Feeder Assembly	table 8-4 on page 453
RG5-1844-050CN	DC Controller PCA	table 8-5 on page 456
RG5-1845-000CN	Paper Size Sensing PCA, Trays 2 and 3	table 8-6 on page 458
RG5-1845-000CN	Cassette-Size Sensing PCA	table 8-8 on page 462
RG5-1846-000CN	Switch / Sensor PCA	table 8-5 on page 456
RG5-1847-000CN	Main Gear Assembly	table 8-3 on page 451
RG5-1849-000CN	Fuser Cable 1	table 8-6 on page 458
RG5-1850-000CN	Fuser Cable 2	table 8-6 on page 458
RG5-1852-160CN	Paper Input Unit (PIU)	table 8-3 on page 451

Table 8-11. Numerical Parts List (continued)

RG5-1859-000CN	Sensor Cable, Paper Input Unit	table 8-4 on page 453
RG5-1860-000CN	PIU PCA	table 8-4 on page 453
RG5-1861-000CN	Paper Pickup Cable	table 8-4 on page 453
RG5-1863-200CN	Fusing Assembly 100-120V	table 8-3 on page 451
RG5-1870-000CN	Cover Assembly	table 8-2 on page 449
RG5-1871-190CN	Fusing Assembly 220-240V	table 8-3 on page 451
RG5-1874-000CN	Face-Down Delivery Assembly	table 8-3 on page 451
RG5-1875-000CN	Face-up Solenoid Assembly	table 8-3 on page 451
RG5-1876-000CN	Low Voltage Power Supply, 110-120V	table 8-6 on page 458
RG5-1878-000CN	Low Voltage Power Supply, Universal	table 8-6 on page 458
RG5-1880-100CN	Tray 1 Pickup Assembly	table 8-3 on page 451
RG5-1883-000CN	Tray 1 Door	table 8-3 on page 451
RG5-1884-000CN	Tray 1 PCA	table 8-3 on page 451
RG5-1887-000CN	Transfer Roller Assembly	table 8-3 on page 451
RG5-1888-000CN	High Voltage Power Supply	table 8-5 on page 456
RG5-1895-000CN	Laser / Scanner Assembly	table 8-5 on page 456
RG5-1915-040CN	Right Cover Assembly, Printer Engine	table 8-2 on page 449
RG5-1919-000CN	Main Motor Cable	table 8-3 on page 451
RG5-1920-000CN	Cassette Size Sensor Cable	table 8-6 on page 458
RG5-1921-000CN	Fan 3 Cable	table 8-6 on page 458
RG5-1924-000CN	Cable Assembly, Laser/Scanner	table 8-5 on page 456
RG5-1925-000CN	Scanner Motor Cable	table 8-5 on page 456
RG5-1926-000CN	BD Cable	table 8-5 on page 456
RG5-1927- 000CN	ILS Cable	table 8-5 on page 456
RG5-1928-000CN	Registration Cable	table 8-6 on page 458
RG5-1928-000CN	Connector, 3P	table 8-6 on page 458
RG5-3852-000CN	Outrigger	table 8-8 on page 462
RG5-3863-000CN	Adjustable Feet Tip	table 8-8 on page 462
RG5-3909-000CN	Power Supply Cable (PSU)	table 8-8 on page 462
RG5-3951-000CN	Tray 2	table 8-1 on page 446
RG5-3952-000CN	Tray 3	table 8-1 on page 446
RG5-4021-000CN	Universal Power Supply	table 8-8 on page 462
RG5-4384-000CN	Front Panel (Control Panel Display)	table 8-2 on page 449
RG5-4403-000CN	Paper Feed Assembly (VTU)	table 8-8 on page 462

Table 8-11. Numerical Parts List (continued)

RG5-4410-000CN	Paper Pickup Assembly	table 8-8 on page 462
RG5-4416-000CN	Paper Deck Drive Assembly	table 8-8 on page 462
RG5-4420-000CN	Tray 4 Assembly	table 8-8 on page 462
RG5-4421-000CN	Tray 5 Assembly	table 8-8 on page 462
RG5-4440-000CN	Main Cable	table 8-8 on page 462
RG5-4441-000CN	Front LED PCA	table 8-8 on page 462
RG5-4442-000CN	2 x 500-sheet Input Tray Controller PCA	table 8-8 on page 462
RG5-4726-000CN	Cable Assembly, Control Panel	table 8-2 on page 449
RG9-1150-000CN	Diverter Assembly	table 8-2 on page 449 table 8-4 on page 453
RH3-2205-000CN	Power Supply	table 8-9 on page 465
RH7-1260-000CN	Main Motor	table 8-3 on page 451
RH7-1262-000CN	Pickup Motor	table 8-4 on page 453
RH7-1266-000CN	Fan 1	table 8-5 on page 456
RH7-1266-000CN	Fan 2	table 8-6 on page 458
RH7-1271-000CN	Fan 3	table 8-6 on page 458
RH7-1289-000CN	Fan 4	table 8-4 on page 453
RH7-5119-000CN	Electromagnetic Clutch	table 8-3 on page 451
RH7-5120-000CN	Electromagnetic Clutch (Paper Feed)	table 8-4 on page 453
RH7-5223-000CN	Solenoid Reversing Mechanism	table 8-9 on page 465
RH7-5225-000CN	Solenoid Flipper	table 8-9 on page 465
RS5-0758-000CN	20T Gear	table 8-4 on page 453
RS5-1101-000CN	Conductive Bushing	table 8-4 on page 453
RS5-2463-000CN	Compression Spring, Front	table 8-4 on page 453
RS5-2466-000CN	Compression Spring, Rear	table 8-4 on page 453
RS5-2490-000CN	Tension Spring	table 8-4 on page 453
RS5-8596-000CN	Label, Operation (Special Order)	table 8-2 on page 449
RS5-8605-000CN	Paper Size Guide Label (Trays 2 and 3)	table 8-1 on page 446
RS5-8611-000CN	Cassette Size Labels	table 8-8 on page 462
VD5-0056-301CN	Fuse, LVPS, 110-120V	table 8-6 on page 458
VD7-0646-301CN	Fuse, LVPS, Universal	table 8-6 on page 458
VD7-1893-151CN	Power Supply Fuse	table 8-8 on page 462
VS1-5057-007CN	Connector, 7P	table 8-6 on page 458
WG8-0291-000CN	Photo Interrupter	table 8-4 on page 453 table 8-4 on page 453

Table 8-11. Numerical Parts List (continued)

XA9-0872-000CN	Screw, with Washer, M3X8	table 8-2 on page 449 table 8-3 on page 451 table 8-5 on page 456 table 8-6 on page 458
XA9-0605-000CN	Screw, tapping, M4X8	table 8-3 on page 451
XA9-0817-000CN	Screw, w/washer, M3X20	table 8-3 on page 451 table 8-5 on page 456
XB4-7300-809CN	Screw, tapping, truss head, M3X8	table 8-5 on page 456
XB4-7401-009CN	Screw, tapping, pan head, M4X10	table 8-5 on page 456
XB5-7303-007CN	Screw, CT, M3X3	table 8-5 on page 456 table 8-6 on page 458
XB6-7400-807CN	Screw, M4X8	table 8-3 on page 451
XZ9-0379-000CN	Front Door Latch	table 8-2 on page 449
XZ9-0379-000CN	Latch, 2 x 500-sheet Input Tray	table 8-8 on page 462
XZ9-0442-000CN	Caster	table 8-8 on page 462

Index

Numerics

- 2 x 500-sheet input tray
 - electrical specifications 9
- 2 x 500-sheet input tray (trays 4 & 5)
 - back cover 296
 - diagnostics 418
 - dimensions 7
 - identification label 6
 - operation 123
 - ordering 20
 - paper paths and components 122
 - parts and diagrams 462
 - printing from 137
 - removing and replacing 151, 295
 - specifications 4
 - verifying installation 342
 - vertical transfer unit 298
 - weight 7
- 2000-sheet input tray (tray 4)
 - adjustment procedure 94, 95
 - dimensions 7
 - electrical specifications 9
 - identification label 6
 - ordering 20
 - paper paths and components 121
 - printing from 137
 - removing and replacing 151
 - specifications 5
 - troubleshooting 427
 - verifying installation 342
 - weight 7
- 5-bin mailbox with stapler, *see* mailbox
 - with stapler
- 7-bin tabletop mailbox 154
 - back cover 263, 264
 - c-link (communication link) 128
 - diagnostics 422
 - dimensions 7
 - electrical specifications 9
 - empty sensor 278
 - full bin and interlock 280
 - identification label 6
 - operation 126
 - ordering 20
 - output modes 126
 - paper paths and components 124
 - parts and diagrams 464
 - removing and replacing 154, 259
 - specifications 5
 - stand
 - dimensions and weight 8
 - ordering 21
 - standard output 275

- verifying installation 342
- weight 7

A

- AC access cover 160
- AC power
 - distribution 99, 100
 - troubleshooting 332
- accessories
 - cleaning 88
 - diagnostics 418
 - dimensions 7
 - locations 19
 - ordering 20
 - parts and diagrams 443
 - specifications 4, 7
 - status 80
 - user installable 147
 - verifying installation 342
 - weight 7
- acoustic emissions 10
- adhesive labels, *see* labels
- adjustable foot tip, 2 x 500-sheet input tray 324
- anti-curl strings, mailbox 246
- anti-static wrist wrap 147
- attention light 53

B

- back cover
 - removing and replacing 162
- back plate, stapler 250
- background scatter, troubleshooting 400
- bins
 - mailbox with stapler 244
 - multibin mailbox 244
 - specifications 5
- black lines, troubleshooting 399
- black page, troubleshooting 396
- blank page, troubleshooting
 - general 396
 - middle of page 407
 - partial 406

- blind cover, mailbox 244
- bubble print, troubleshooting 405

C

- cables
 - c-link, troubleshooting 346
 - main, 2 x 500-sheet input tray 318
 - ordering 23
 - parallel 142
- cancel job key 52
- capacity, paper trays 4
- cartridge slots 2
- cassette-size sensing PCA, 2 x 500-sheet input tray 315
- casters, 2 x 500-sheet input tray 323
- characters improperly formed, voids 402
- cleaning
 - printer and accessories 88
 - spilled toner 90
 - toner cartridge drum 110
- c-link cables
 - 7-bin tabletop mailbox 128
 - troubleshooting 346
- clutches
 - diagram 434
 - drive signals 105
 - locations 117
- cold reset 55
 - paper size 54, 75, 79
 - printer memory 85
- communications link, *see* c-link cables
- compressed print, troubleshooting 406
- CompuServe forum 32
- configuration menu 67
- configuration page
 - printing 80
 - troubleshooting 342
- consumables, printer 29
- control panel
 - default settings 54
 - display, selecting a menu item 58
 - keys 52
 - language 55
 - layout 52
 - lights 53
 - overriding settings 54, 416
 - removing and replacing 159
 - status 80, 82
 - troubleshooting 336
- control panel menus 58
 - configuration 67
 - EIO 72
 - information 59
 - I/O 70
 - map 83, 341
 - paper handling 60

- print quality 62
- printing 64
- resets 74
- service mode 76
- controller PCA
 - 2 x 500-sheet input tray 314
 - 7-bin tabletop mailbox 269
 - mailbox with stapler 245
 - multibin mailbox 245
 - stapler 252
- covers
 - AC access, printer 160
 - back, printer 162
 - cleaning 90
 - front
 - 7-bin tabletop mailbox 260
 - printer 163
 - front top, 2 x 500-sheet input tray 304
 - latch, 7-bin tabletop mailbox 294
 - left lower, printer 165
 - left, 2 x 500-sheet input tray 297
 - mailbox with stapler 223
 - multibin mailbox 223
 - parts and diagrams 449
 - removing and replacing 160
 - right, 2 x 500-sheet input tray 301
 - top
 - 7-bin tabletop mailbox 265
 - printer 166
 - stapler 255
- curl, troubleshooting 431

D

- daisy chain connections 346
- data light 53
- DC controller PCA
 - diagrams 435
 - function 105
 - removing 197
 - system 105
- DC power 99
- Declaration of Conformity 40
- default settings
 - control panel 54
 - restoring 74
- delivery head
 - assembly, mailbox 224
 - position motor, mailbox 240
- delivery unit (standard output bin)
 - fan 182
 - removing 169
- depth, printer and accessories 47
- developing images 113
- diagnostics, accessories 418
- diagrams 432, 442

- dimensions, printer and accessories 7, 47
- DIMM
 - installing 147
- disk, *see* hard disk
- diverter assembly
 - 7-bin tabletop mailbox 286
 - removing and replacing 172
- diverter door assembly
 - removing and replacing 173
- documentation, ordering 24
- door assembly
 - jam access, mailbox 232
 - right lower 174
 - right, 7-bin tabletop mailbox 271
- doors
 - parts and diagrams 449
- draft mode, *see* EconoMode
- driver
 - overriding control panel settings 54, 416
 - troubleshooting 350
- dropouts, troubleshooting 398
- drum
 - cleaning 110
 - conditioning 111
 - rotation functional check 410
- duplexer
 - about 137
 - dimensions 8
 - memory requirements 27
 - ordering 20
 - paper paths and components 117
 - removing and replacing 149
 - specifications 5
 - speed 2
 - standard or optional 3
 - verifying installation 342
 - weight 8
- duty cycle 2

E

- EconoMode 104
- EDO DIMMs, ordering 23
 - see also* memory
- EIO block, troubleshooting 346
- EIO cards
 - ordering 24
 - standard 3
 - status 80
- EIO menu 72
- electrical specifications 9
- electrostatic discharge sensitive (ESD) 145
- emissions, acoustic 10
- encoder assembly and transport belt
 - motor, mailbox 241
- engine test
 - microswitch 106
 - troubleshooting 335
- envelope feeder
 - dimensions 8
 - ordering 20
 - paper paths and components 117
 - printing from 137
 - removing and replacing 150
 - specifications 5
 - verifying installation 342
 - weight 8
- envelopes
 - guidelines 11
 - paper jams 428
 - troubleshooting 427, 429
- environment
 - operating printer 46
 - requirements, printer 49
- environmental product stewardship 36
- ESD, *see* electrostatic discharge sensitive
- event log 336
 - clearing 75
 - listed on configuration page 82
 - troubleshooting 336
- exchange program 29
- exhaust
 - fan 1 (laser/scanner) 177
 - fan 2 (lvps) 179
 - fan 4 (delivery unit) 182

F

- factory settings 54, 85
- fading print, troubleshooting 397, 428
- fan 1, laser/scanner
 - removing and replacing 177
- fan 2, lvps
 - removing and replacing 179
- fan 3, formatter
 - removing and replacing 180
- fan 4, delivery unit
 - removing and replacing 182
- fans
 - fan motors 106
 - locations 117
- faulty registration, troubleshooting 403
- Fax Information Retrieval Support
 - Technology 31
- FCC statement 35
- feed rollers
 - 2 x 500-sheet input tray 313
 - cleaning 90
 - tray 1 210
 - trays 2 & 3 212

- feed system
 - 2 x 500-sheet input tray 123
 - feeder assembly 183
 - removing and replacing 183
 - field replaceable units, ordering 28
 - Finland laser statement 43
 - first page different, troubleshooting 429
 - 5-bin mailbox with stapler, *see* mailbox with stapler
 - flash DIMMs, ordering 23
 - see also* memory
 - flashing light 53
 - flipper assembly
 - 7-bin tabletop mailbox 286
 - solenoid 291
 - mailbox with stapler 227
 - multibin mailbox 227
 - flowchart, troubleshooting 328
 - fonts
 - internal 2
 - ordering 23
 - foot tip, 2 x 500-sheet input tray 324
 - formatter assembly 78
 - fan 180
 - function 102
 - part locations 18
 - removing 185
 - system 102
 - front cover
 - 7-bin tabletop mailbox 260
 - front door, 2 x 500-sheet input tray 321
 - front LED PCA, 2 x 500-sheet input tray 326
 - front top cover, 2 x 500-sheet input tray 304
 - FRUs, *see* field replaceable units
 - FTP, technical assistance 32
 - functional block diagram 98
 - functional overview 97
 - fusing assembly
 - cleaning 90
 - removing 187
 - fusing images
 - about 116
 - troubleshooting 429
- G**
- go key 52
- H**
- half self test functional check 409
 - handle, 7-bin tabletop mailbox 292
 - hard disk
 - about 26
 - ordering 23
 - removing and replacing 148
 - standard or optional 3
 - status 80
 - verifying installation 342
 - hardware table 157
 - Hardware Technical Support Center (HTSC) 32
 - height, printer and accessories 7, 47
 - high voltage power supply
 - check 410
 - contacts 101, 108
 - distribution 101
 - removing and replacing 205
 - hinges, stapler 258
 - HP ASAP (Automated Support Access Program) 31
 - HP CompuServe Forum 32
 - HP FIRST (Fax Information Retrieval Support Technology) 31
 - HP JetDirect print server card, *see* EIO cards
 - HP JetDirect Print Server Software Installation Guide*, ordering 24
 - HP JetSend, IP addresses 82
 - HP LaserJet paper, ordering 22
 - HP LaserJet Printer Family Paper Specification Guide*, ordering 24
 - HP multi-purpose paper, ordering 22
 - HP reseller sales and service support 32
 - HP Support Line 28
 - HP's Distribution Center 28
 - HTSC, *see* Hardware Technical Support Center
 - humidity, printer 49
 - hvps, *see* high voltage power supply
- I**
- identification, printer 6
 - illustrations and parts lists 444
 - image formation
 - block diagram 107
 - developing 113
 - fusing 116
 - system 107
 - transferring 115
 - writing 112
 - image quality, troubleshooting 394
 - image skew, troubleshooting 404, 427
 - images per month 2
 - indicator lights 53
 - information menu 59
 - input paper guide, mailbox 230
 - input sources 136
 - intake, fan 3 (formatter) 180
 - interface accessories, ordering 23
 - interfaces, standard 3

- interlock
 - switch, mailbox 231
- internet, technical assistance 32
- IP addresses 82
- item key 52
- I/O menu 70
- I/O troubleshooting 346

J

- jam access door assembly, mailbox 232
- JetSend, *see* HP JetSend

K

- keys, control panel 52

L

- labels
 - adhesive, guidelines 12
 - paper jams 428
 - printer identification 6
- languages (personalities) 147
 - removing and replacing 147
 - standard printer 2
 - status 80
 - verifying installation 342
- languages, control panel 55
- laser statement for Finland 43
- laser/scanner 189
 - drive 105
 - fan 177
 - motors 106
- latching mechanism, 7-bin tabletop mailbox 293
- latch, 7-bin tabletop mailbox cover 294
- leading edge halo, troubleshooting 400
- LED
 - front PCA, 2 x 500-sheet input tray 326
 - PCA, 7-bin tabletop mailbox 282
 - troubleshooting 421
- left cover
 - 2 x 500-sheet input tray 297
- left lower cover 165
- left output bin
 - specifications 5
- left output bins
 - 7-bin tabletop mailbox
 - diverter assembly (flipper) 286
 - sensors pca 283
- leveling feet (outriggers), 2 x 500-sheet input tray 322
- light print, troubleshooting 397, 428
- lights, control panel 53
- lines, troubleshooting 399
 - edge of paper 402
 - white 405

- LocalTalk cable, ordering 23
- locating pins
 - 2 x 500-sheet input tray 325
 - 2000-sheet input tray 95
- location, printer 46
- low voltage power supply
 - distribution system 99
 - fan 179
 - removing and replacing 206
- lower elevator pulley assemblies, mailbox 235
- lvps, *see* low voltage power supply

M

- Macintosh network cable kit, ordering 23
- mailbox with stapler
 - electrical specifications 9
 - identification label 6
 - operation 133
 - ordering 20
 - paper jams 428
 - removing and replacing 153, 223
 - specifications 5
 - troubleshooting 428
 - verifying installation 342
 - wiring diagram 440
- main cable, 2 x 500-sheet input tray 318
- main gear assembly 191
 - removing and replacing 191
- main motor assembly 106
 - removing and replacing 194
- maintenance
 - count, setting 78, 185
 - kit, ordering 24
 - preventative 91
- manuals, ordering 24
- mass storage, *see* hard disk drive
- media separation 115
- media, *see* paper
- memory
 - installing
 - see also* memory
 - ordering 23
 - removing and replacing 147
 - requirements 26
 - standard 3
 - status 80
 - verifying installation 342
- menu key 52
- menu map page 83, 341
- menus, *see* control panel menus
- metallic tape and housing assembly, mailbox 237
- minus key 52
- model number 6
- monthly usage 2

- motors
 - controlled by DC controller 106
 - delivery head position, mailbox 240
 - diagram 434
 - fan 1 178
 - fan 3 180
 - locations 117
 - main assembly 194
 - reversing mechanism, 7-bin tabletop mailbox 284
 - transport belt and encoder assembly, mailbox 241
 - multibin mailbox
 - paper path 121
 - removing and replacing 153, 223
 - multi-bin mailbox
 - dimensions 8, 48
 - electrical specifications 9
 - identification label 6
 - ordering 20
 - paper jams 428
 - power box, ordering 24
 - space requirements 48
 - specifications 5
 - stapler operation 133
 - troubleshooting 428
 - verifying installation 342
 - weight 8
 - multi-purpose tray, *see* tray 1
- N**
- network cards, *see* EIO cards
 - networks, troubleshooting 346
 - noise, printer 10
 - troubleshooting 426
- O**
- operating environment 46
 - operating overview 51
 - options, *see* accessories
 - ordering parts 28, 442
 - output paper sensor PCA
 - removing and replacing 198
 - outriggers (leveling feet), 2 x 500-sheet input tray 322
 - overcurrent/overvoltage protection 100
 - overhead transparencies, *see* transparencies
 - overriding control panel settings 54, 416
- P**
- page count 82
 - setting 75, 78, 185
 - troubleshooting 427
 - page skew, troubleshooting 404, 427
 - pages per minute (ppm) 2
 - paper
 - curl, troubleshooting 431
 - ordering 22
 - selection guidelines 11
 - shipping 13
 - sizes 4
 - memory requirements 27
 - specifications guide, ordering 24
 - storing 13
 - weight 4
 - paper deck drive assembly, 2 x 500-sheet input tray 311
 - paper handling
 - accessories
 - locations 19
 - ordering 20
 - paper handling components
 - parts and diagrams 446
 - paper handling menu 60
 - paper input unit (PIU) 195
 - removing and replacing 195
 - sensor 214
 - paper jams
 - detection 138
 - multi-bin mailbox or mailbox with stapler 428
 - troubleshooting 412, 414, 416
 - paper motion monitoring and control 105
 - paper path
 - cleaning 89
 - cover, 7-bin tabletop mailbox 271
 - test 80, 415
 - troubleshooting 414
 - paper paths and components
 - 2 x 500-sheet input tray 122
 - 7-bin tabletop mailbox 124
 - duplexer 117
 - envelope feeder 117
 - printer 117
 - stapler 131
 - paper size
 - cold reset 54, 75, 79
 - PCA, removing and replacing 202
 - paper size switches
 - 2 x 500-sheet input tray 122
 - trays 2 & 3 136
 - paper source default 54
 - paper tray
 - capacities 4
 - settings, status 80
 - storage, 2 x 500-sheet input tray 320
 - parallel cables 142
 - ordering 23
 - partial blank page, troubleshooting 406

- parts 441
 - diagrams 441
 - locations 14
 - ordering 28, 442
- PCL
 - fonts 2
 - memory requirements 27
- PCL 5e and PCL 6 2
- PCL 5/PJL Technical Reference Documentation Package*, ordering 24
- personalities, *see* languages
- phone numbers
 - ordering parts 28
 - technical assistance 31
- PhoneNET cable, ordering 23
- photosensitive drum 109
- pickup
 - 2 x 500-sheet input tray 123, 309
- pickup motors 106
- pickup rollers
 - 2 x 500-sheet input tray 313
 - cleaning 90
 - trays 2 & 3 212
- pin configuration, parallel 142
- pins, locating
 - 2 x 500-sheet input tray 325
 - 2000-sheet input tray 95
- PIU, *see* paper input unit
- plus key 52
- PM kit, *see* preventative maintenance
- PostScript Level 2 emulation (PS) 2
 - fonts 2
 - memory requirements 27
- power box, ordering 24
- power distribution system 99
- power rating 6
- power supply
 - 2 x 500-sheet input tray 123, 317
 - 7-bin tabletop mailbox 270
 - see also* high voltage power supply or low voltage power supply
- PowerSave mode 9
 - troubleshooting 428
- powersave mode 102
- ppm, *see* pages per minute
- preventative maintenance 91
 - count 78, 185
 - kit, ordering 24
- print
 - resolution 2
 - speed 2
- print density adjustment 101
- print media, *see* paper
- print quality
 - cleaning printer 88
 - troubleshooting 394
- print quality menu 62
- printer
 - comparisons of features 3
 - dimensions 7, 47
 - electrical specifications 9
 - features 2
 - paper paths and components 117
 - part locations 441
 - parts and diagrams 451
 - specifications 7
 - testing 80
 - weight 7
- printer stand
 - dimensions and weight, 7-bin tabletop mailbox 8
 - ordering 21
- printing menu 64
- printing supplies 22
- PS1, *see* registration sensor
- PS2, *see* paper input unit sensor
- PS, *see* PostScript Level 2 emulation

R

- ready light 53
- ready reference guide, ordering 25
- recycling toner cartridges 30
- registration assembly
 - removing and replacing 207
 - roller, cleaning 89
 - sensor 216
- registration faulty, troubleshooting 403
- regulatory information 6
- remanufactured assemblies 29
- removal and replacement
 - strategy 145
 - tools required 146
- repair process 28
- repetitive defects
 - troubleshooting 401
- repetitive defects, troubleshooting ruler 408
- required tools 146
- reset
 - cold 85
 - printer 55
- resets menu 74
- resolution 2
- resolution enhancement (REt) 2, 103
- reversing mechanism
 - motor, 7-bin tabletop mailbox 284
 - solenoid, 7-bin tabletop mailbox 290
- right cover
 - 2 x 500-sheet input tray 301
- right door assembly, 7-bin tabletop mailbox 271
- right lower door assembly 174

- rollers
 - 2 x 500-sheet input tray 313
 - cleaning 90
 - transfer 219
 - tray 1 210
 - trays 2 & 3 212
- S**
- saving
 - power 9, 102
 - toner 104
- scanner, *see* laser/scanner
- screwdrivers, required 146
- screws 157
 - self-tapping 146
- SDRAM DIMMs, ordering 23
 - see also* memory
- security, status 80, 82
- select key 52
- self test, *see* configuration page
- sensors
 - 7-bin tabletop mailbox
 - empty bin 278
 - left output 283
 - diagram 433
 - locations 117
 - output paper 198
 - paper input unit (PIU) 214
 - registration 216
- separation drum 115
- separation pad
 - cleaning 90
 - tray 1 211
- separation rollers
 - 2 x 500-sheet input tray 313
 - trays 2 & 3 212
- serial number 6, 82
 - setting 75, 78, 185
 - troubleshooting 427
- server, troubleshooting 350
- service
 - approach 28
 - during and after the warranty 34
- service manual, ordering 25
- service mode 75
- settings and defaults 416
- 7-bin tabletop mailbox
 - c-link (communication link) 128
 - diagnostics 422
 - dimensions 7
 - identification label 6
 - operation 126
 - ordering 20
 - output modes 126
 - paper paths and components 124
 - parts and diagrams 464
- removing and replacing 154, 259
- specifications 5
- stand
 - dimensions and weight 8
 - ordering 21
 - verifying installation 342
 - weight 7
- shipping print media 13
- short tray 7, 7-bin tabletop mailbox 289
- site requirements 45
- size settings, status 80
- sizes, paper 4
 - memory requirements 27
- skew, troubleshooting 404, 427
- SL3, *see* solenoid assembly
- slides, *see* transparencies
- smeared toner, troubleshooting 400
- SME, *see* Support Materials Europe
- SMO, *see* Support Materials Organization
- solenoid assembly 218
- solenoids
 - 7-bin tabletop mailbox
 - flipper 291
 - reversing mechanism 290
 - diagram 434
 - locations 117
- space requirements 47
- specifications
 - acoustic emissions 10
 - electrical 9
 - guide, ordering 24
 - paper trays, bins, and accessories 4
 - print media 11
 - printer and accessories 7
- speed (pages per minute) 2
- stand
 - dimensions and weight, 7-bin tabletop mailbox 8
 - ordering 21
- standard output bin
 - 7-bin tabletop mailbox 275
- standard output bins
 - delivery unit 169
 - specifications 5
- stapler
 - dimensions 8
 - non-HP cartridges 30
 - operation 133
 - paper jams 428
 - paper paths and components 131
 - parts and diagrams 460
 - removing and replacing 249
 - stapler bed assembly 256
 - verifying installation 342
 - weight 8

- storage
 - 2 x 500-sheet input tray
 - front door 321
 - paper tray 320
 - print media (paper) 13
 - printer environment 49
 - strings, anti-curl, mailbox 246
 - supplies
 - ordering information 20
 - parts and diagrams 443
 - Support Materials Europe (SME) 28, 442
 - Support Materials Organization (SMO) 28, 442
 - switches
 - 2 x 500-sheet input tray, paper size 122
 - diagram 433
 - mailbox with stapler, interlock 231
 - multibin mailbox, interlock 231
 - trays 2 & 3, paper size 136
- T**
- technical assistance 31
 - temperature, printer 49
 - test
 - accessories 418
 - printer 80, 342, 415
 - timing, printer 138
 - toner cartridge
 - cleaning spills 90
 - contacts 101, 108
 - detection 101
 - image formation 108
 - life expectancy 29
 - ordering 22
 - recycling 30
 - refilled 30
 - troubleshooting 395
 - warranty 30
 - weight 7
 - toner smear, troubleshooting 400
 - tools, required 146
 - top cover 166
 - 7-bin tabletop mailbox 265
 - stapler 255
 - transfer roller assembly 219
 - cleaning 90
 - transferring images 115
 - transparencies
 - guidelines 13
 - paper jams 428
 - transport belt and encoder assembly
 - motor, mailbox 241
 - tray 1
 - printing from 137
 - removing and replacing 210, 221
 - specifications 4
 - tray 4, see 2000-sheet input tray
 - or 2 x 500-sheet input tray
 - tray 5, see 2 x 500-sheet input tray
 - tray 7 (short), 7-bin tabletop mailbox 289
 - tray selection 54
 - troubleshooting 427, 429
 - tray settings, status 80
 - trays 2 & 3
 - adjustment procedure 92
 - ordering 20
 - pickup motor 106
 - printing from 136
 - removing and replacing 212, 222
 - specifications 4
 - trays 4 & 5, removing and replacing 307
 - troubleshooting
 - accessories 418
 - c-link cables 346
 - communication 346
 - control panel 336
 - drum rotation functional check 410
 - engine test 335
 - event log 336, 351
 - general 426
 - half self test functional check 409
 - high voltage power supply check 410
 - image quality 394
 - paper curl 431
 - paper jams 412, 414, 416
 - power-on 332
 - print quality 394
 - printer stops/hangs 428
 - process 328
 - toner cartridge 395
 - 2 x 500-sheet input tray (trays 4 & 5)
 - diagnostics 418
 - dimensions 7
 - identification label 6
 - operation 123
 - ordering 20
 - paper paths and components 122
 - parts and diagrams 462
 - printing from 137
 - removing and replacing 151, 295
 - specifications 4
 - verifying installation 342
 - weight 7
 - 2000-sheet input tray (tray 4)
 - adjustment procedure 94, 95
 - dimensions 7
 - electrical specifications 9
 - identification label 6
 - ordering 20
 - paper paths and components 121
 - printing from 137
 - removing and replacing 151

- 2000-sheet input tray (tray 4) (continued)
 - specifications 5
 - troubleshooting 427
 - verifying installation 342
 - weight 7
- typefaces, *see* fonts

U

- user guide, ordering 24
- user installable accessories 147

V

- value key 52
- VCCI statement (Japan) 42
- vertical transfer unit, 2 x 500-sheet input tray 298
- voids, troubleshooting 402, 428

W

- warranty 33
- weight
 - paper 4
- white page, troubleshooting 396
- white stripes, troubleshooting 405
- width, printer and accessories 7, 47
- wiring diagram
 - mailbox with stapler 440
- world wide web, technical assistance 32
- writing images 112